



**CONQUER***DIRT*

 **YAMAHA**  
*Revs Your Heart®*

## OFF-ROAD MOTORCYCLES

YZ®450F/ YZ®450FX .....	6
YZ®250F/ YZ®250FX .....	22
WR®450F/ WR®250F .....	38
YZ®250/ YZ®250X .....	52
YZ®125 .....	62
YZ®85 .....	72
TT-R250™/ TT-R230™/ TT-R125™ .....	79
TT-R110™ / TT-R50™ .....	82

## UNIVERSAL

ELECTRICAL.....	86
MISCELLANEOUS .....	92
RAMPS .....	94
STANDS & MATS .....	95
STRAPS & TIE DOWNS .....	96

## QUICK-REFERENCE GUIDE - YAMALUBE®/YAMAHA GENUINE PARTS

OFF-ROAD MOTORCYCLE.....	99
--------------------------	----

CALIFORNIA REGULATIONS REGARDING EMISSION-RELATED  
PARTS AND ACCESSORIES .....INSIDE BACK COVER



# OFF-ROAD ACCESSORIES



**DON'T EXPECT IT.  
DEMAND IT!™**

When your Yamaha needs scheduled service, maintenance, repair, or that perfect accessory, nothing can replace **Yamaha Genuine Parts & Accessories**. Genuine parts are just that, the same high-quality parts originally specified by the engineers for your Yamaha. What's more, Yamaha Accessory engineers work hand-in-hand with the same team of engineers that designed your Yamaha to develop Yamaha Genuine Accessories.

Making your vehicle look and perform as only a Yamaha can takes advanced research and the use of state-of-the-art materials. But that's not all. By continually subjecting these parts and accessories to a demanding testing program designed to evaluate functionality and durability, we give you peace of mind – no need to worry about inferior aftermarket parts.

Yamaha Genuine Accessories always deliver the highest fit, finish, and style while Yamaha Genuine Parts provide the same true quality and performance as the original part that was on your Yamaha, every time.

Whether in the dirt, on the road, through the snow, or over the water... **Don't Expect It, Demand It!™**



WATCH FOR THE **"MUST HAVE"** LOGOS THROUGHOUT THE CATALOG. THESE HAND-PICKED, ESSENTIAL ACCESSORIES ARE THE STARTING POINT FOR YOU TO BUILD YOUR ULTIMATE VEHICLE.

# GYTR

GYTR® REAR SPROCKET

**GYT-75339-48-BL**

See Page 18 A for full product details



GYTR® 14MM TIMING PLUG

**GYT-2S235-14-AL**

See Page 19 F for full product details



GYTR® MX GLIDE PLATE

**1SL-F14B0-S0-00**

See Page 16 B for full product details



GYTR® BILLET IGNITION COVER

**1SL-E54E0-V0-00**

See Page 9 B for full product details



GYTR® BILLET OFFSET AXLE BLOCKS

**33D-F53M0-V0-00**

See Page 19 G for full product details



GYTR® PANEL STAND

**GYT-YZRWK-ST-00**

See Page 95 A for full product details



# PODIUM PACKAGE



© 2014 Yamaha Motor Co., Ltd. All rights reserved. Yamaha, the Yamaha logo, and YZF are registered trademarks of Yamaha Motor Co., Ltd. in the U.S.A. and other countries.

**COVERS**

**GRAPHICS**

**HANDLEBARS & CONTROLS**

**PERFORMANCE**

**PROTECTION**

**SEATS**

**SPROCKETS & CHAINS**

**TRIM & ACCENTS**

**WHEELS**

**A. NEW! YZ MOTORCYCLE COVER**

Keep your YZ protected from dust at the track or in your garage with this Yamaha cover.

- Traditional Yamaha racing blue color featuring the GYTR, Yamalube® and bLU cRU® logos
- Lightweight material that can be quickly rolled up into the convenient attached storage bag
- Water resistant
- Equipped with a drawstring at the bottom to keep the cover in place

**NOTE:** Recommended for storage use only; not for trailering or transport

*Fits all YZ models except YZ85*

**1SL-F81A0-V0-00** (Blue) .....\$69.99



**A**

**B. NEW! GRAPHIC KIT BY D’COR VISUALS®**

This 16-piece graphic kit covers the plastics and the swingarm of the 2014-2017 YZ450F.

- Thick, durable vinyl construction featuring the GYTR, Yamalube and bLU cRU logos
- Proper colored number plate backgrounds – white for YZ450F
- Easy way to enhance the style of your YZ and refresh worn plastics
- Super strong adhesive holds up through tough riding conditions

*Fits '14-’17 YZ450F*

**DBY-ACC56-34-86** .....\$129.99



**B**

**C. GYTR® PIVOTING LEVERS BY ARC™**

These levers are designed with a folding-pivot blade that will fold in the event of a tip-over. Pivot ratio mimics stock for excellent performance.

*Fits '09-’17 YZ450F*

**17D-H39B0-V0-00** (Clutch) (Black) .....\$75.99

*Fits '17 YZ450FX*

**2GB-H39B0-V0-00** (Clutch) (Black) .....\$72.99

*Fits '01-’08 YZ450F*

**GYT-5XC37-20-00** (Clutch) (Black) .....\$75.99

*Fits '05-’17 YZ450F; '16-’17 YZ450FX*

**GYT-5XC37-30-00** (Brake) (Black) (Shown) .....\$75.99



**C**

**D. GYTR® 10" CROSSBAR PAD**

Designed for handlebars with crossbar. Printed on scratch resistant, 15 mil. vinyl featuring the Yamaha logo.

*Fits all Off-road Models with crossbar-equipped handlebars*

**GYT-CROSS-BR-02** (Blue) .....\$12.99

**E. GYTR® YAMAHA FACTORY RACING CLAMP COVER FOR 1-1/8" HANDLEBARS**

Printed on scratch-resistant 15-mil vinyl, featuring the Factory Racing logo. 10" long. For 1-1/8" handlebars.

*For all Off-road Motorcycles with 1-1/8" handlebars*

**GYT-5XC25-18-BL** (Blue) .....\$21.99



**D**

**F. SCOTT® MX2 GRIPS**

Designed for superior grip and comfort. Features underside waffle and soft-ridged upper patterns. Race proven. Grooved for safety wire. Sold in pairs.

*Fits '03-’17 YZ450F; '17 YZ450FX*

**ABA-YZRMX-GP-BK** (Black) .....\$9.99



**E**



**F**



A

**A. GPR® STEERING STABILIZER**

GPR® Stabilizers are precision-machined for proven reliability and superior quality. Kit comes with the GPRV1 stabilizer and billet-machined mounting brackets. The patented "pin-less" mounting brackets eliminates any slop that might normally exist with the traditional aftermarket pin-and-slot mounting systems. Easy installation provides bolt-on performance. No drilling, tapping, or welding required. Intended to fit with OEM bars.

Fits '14~'17 YZ450F; '16~'17 YZ450FX

DBY-ACC56-34-63 .....\$495.00

**B. CYCRA® FACTORY PROBEND® CRM RACER PACK**

Exclusive Yamaha color way and shield graphics. Factory Edition Probend CRM Complete Racer Pack includes: center reach bars, center reach mounting clamps, classic Enduro shields, Powergrip alloy bar ends, and all necessary hardware. Revolutionary patented billet construction. Trademarked Probend® shape. Replaceable integrated plastic abrasion guard; center reach clamps provide maximum bite to secure hand guards and allows for superior clearance on a wide range of bars. Powergrip alloy bar ends fit standard and oversized bars. Sold in pairs.

Fits '05~'17 YZ450F; '16~'17 YZ450FX

DBY-ACC56-34-69 (White) .....\$169.99

DBY-ACC56-34-70 (Blue) .....\$169.99

**C. CYCRA® REBOUND HAND SHIELDS**

Unrivaled strength against trail debris. Vigorously tested for durability and quality assurance. Great alternative to wraparound systems for woods or MX. Patented folding shield for those unexpected obstacles or accidental falls. Billet aluminum mounts and reinforced backbone on shield. In-molded rubber edge provides increased protection. Can be mounted over or under bars for easy installation and clean hand control area. Includes shields, mounts, and hardware. Sold in pairs.

Fits '05~'17 YZ450F; '16~'17 YZ450FX

DBY-ACC56-34-71 (Black) .....\$79.99

DBY-ACC56-34-72 (White) .....\$79.99

DBY-ACC56-34-73 (Blue) .....\$79.99

**D. CYCRA® SERIES ONE PROBEND® BAR "U" CLAMP SET**

Cycra® blended the best features of a straight bar and the classic Probend®, to result in the Series One Probend®. Many riders prefer the straight bar end with more of a closed-in area but still want ample room for levers, hands, and controls. Cycra® was able to accommodate both by adding a subtle drop in the bar end.

"U" Clamp Set for ProTaper® Pre-2007/Renthal® Fatbar®/Tag T2 Handlebars. To be used with DBY-ACC56-34-01, DBY-ACC56-34-02 or DBY-ACC56-34-03

Fits '05~'17 YZ450F; '15~'17 YZ450FX

DBY-ACC56-34-04 (Natural) .....\$36.49

"U" Clamp Set for ProTaper® Evo and Contour/Neken. To be used with DBY-ACC56-34-01, DBY-ACC56-34-02 or DBY-ACC56-34-03.

Fits '05~'17 YZ450F; '15~'17 YZ450FX

DBY-ACC56-34-06 (Natural) .....\$44.95



B



C

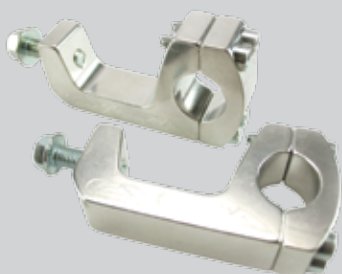

D

COVERS

GRAPHICS

HANDLEBARS &amp; CONTROLS

PERFORMANCE

PROTECTION

SEATS

SPROCKETS &amp; CHAINS

TRIM &amp; ACCENTS

WHEELS

**COVERS**

**GRAPHICS**

**HANDLEBARS & CONTROLS**

**PERFORMANCE**

**PROTECTION**

**SEATS**

**SPROCKETS & CHAINS**

**TRIM & ACCENTS**

**WHEELS**

**A. CYCRA® SERIES ONE PROBEND® HAND GUARDS**

Cycra® blended the best features of a straight bar and the classic Probend®, to result in the Series One Probend®. Many riders prefer the straight bar end with more of a closed-in area but still want ample room for levers, hands, and controls. Cycra® was able to accommodate both by adding a subtle drop in the bar end. Requires "U" Clamp Set (sold separately) for specific type of handlebar.

*Fits '05~'17 YZ450F; '16~'17 YZ450FX*

<b>DBY-ACC56-34-01</b> (Black) .....	<b>\$64.95</b>
<b>DBY-ACC56-34-02</b> (White) .....	<b>\$64.95</b>
<b>DBY-ACC56-34-03</b> (Blue) .....	<b>\$65.49</b>



**A**

**B. GYTR® PORTED CYLINDER HEAD ASSEMBLY**

The GYTR Ported Cylinder Head Assembly comes fully assembled and ready to install with no costly core changes or deposits or exchange programs that can add downtime. CNC milling helps eliminate the variances that hand porting can produce. The head was developed on the flow bench in conjunction with dyno and track testing to ensure the ultimate in performance and durability. GYTR Performance Camshaft Kit is included, as well as stock valve train and cam gears for durability and easy maintenance. GYTR Head Assemblies are used by Yamaha SX/ MX and ATV Race Teams. This accessory is restricted to closed-course use.

*Fits '14~'17 YZ450F*

<b>1SL-E11B0-V0-00</b> (Shown) .....	<b>\$2,122.99</b>
--------------------------------------	-------------------



**B**

**C. GYTR® PERFORMANCE CAMSHAFTS**

Maximize your top-end horsepower with this Performance Cam Kit. Ground to exact specifications using special CNC cam-grinding machines. Special billet alloy construction provides consistent machined surfaces for increased durability. Cams come with durable stock cam gears and de-comp installed, degreed-in, and ready to install. No costly core charges or deposits, or exchange programs that can add to downtime. Designed for use in modified engines equipped with a high compression piston. This accessory is restricted to closed-course use.

*Fits '14~'17 YZ450F*

<b>1SL-E21F0-V0-00</b> .....	<b>\$684.99</b>
------------------------------	-----------------



**C**

**D. GYTR® HIGH COMPRESSION PISTON KIT**

The GYTR High Compression Piston Kit provides a performance boost throughout the rpm range while maintaining a high level of durability. Machined valve pockets provide additional valve clearance when used with higher lift camshafts. The kit includes piston rings, piston pin, and clips (uses stock replacements). Requires use of minimum 100-octane racing fuel. This accessory is restricted to closed-course use.

**IMPORTANT:** GYTR Oil Sprayer (1SL-E16A0-V0-00) is required for GYTR High Compression Piston Kit.

*Fits '14~'17 YZ450F*

<b>1SL-E16A0-V0-00</b> .....	<b>\$255.99</b>
------------------------------	-----------------

*Fits '10~'13 YZ450F*

<b>33D-E16A0-V0-00</b> .....	<b>\$228.95</b>
------------------------------	-----------------

**E. GYTR® OIL SPRAYER**

This oil sprayer is precision constructed out of CNC machined aluminum with a special 2-hole design. Manufactured to exact tolerances for performance and durability. Provides additional under piston lubrication. Required for usage of GYTR Piston.

*Fits '14~'17 YZ450F*

<b>1SL-E16B0-V0-00</b> .....	<b>\$26.99</b>
------------------------------	----------------



**D**



**E**





A

**A. GYTR® OFF-ROAD FLYWHEEL**

This complete flywheel assembly features an increase in inertia mass that smoothes the power delivery. Helps get power to the ground and keep your momentum up through corners and tricky sections, resulting in faster lap times and more race wins. Easy to install, allowing you the opportunity to change flywheels for different types of riding.

- Fits '14~'17 YZ450F*  
**1SL-H13A0-V0-00** .....\$245.99
- Fits '06~'09 YZ450F*  
**GYT-2S297-50-50** .....\$162.99



B

**B. GYTR® BILLET IGNITION COVER**

Constructed of billet aluminum and coated with a hard anodized finish, the GYTR Billet Ignition Cover was developed in conjunction with race teams to provide a stronger cover that limited the risk of loosening oil cap and large timing plug during a race. The improved finish is both durable and attractive. Installation removes the oil cap and large timing plug.

- Fits '14~'17 YZ450F*  
**1SL-E54E0-V0-00** .....\$250.99

**C. GYTR® HIGH-FLOW AIR FILTER**

High-flow, two-layer foam filter offers optimized filtration while maximizing airflow. Increases performance. Filter is completely washable and reusable. Service with Yamaha Genuine Foam Filter Oil. This accessory is restricted to closed-course use.

- Fits '14~'17 YZ450F*  
**1SL-E41C0-V0-00** .....\$27.99
- Fits '10~'13 YZ450F*  
**33D-E41C0-V0-00** .....\$15.95

**D. YAMAHA AIR BOX WASH CAP**

Eases air box cleaning and leaves no gaps that would allow water to penetrate when used. Features a large, tool-less knob and is made of ABS plastic with a fully sealed rubber gasket on the leading edge. It is easy to install and remove.

- Fits '14~'17 YZ450F*  
**1SL-E41E0-V0-00** .....\$38.99



C

**E. YAMAHA GENUINE GASKET KIT**

These original-equipment Top End and Bottom End Gasket Kits were designed for convenience and total savings. Kits include the necessary gaskets, seals, and O-rings needed to reassemble your engine. They also include a complete part number list of all gaskets, seals, and O-rings for an in-depth engine overhaul.

- Fits '17 YZ450F*  
**B11-W0001-00-00** (Top End) .....\$79.06  
**B11-W0002-00-00** (Bottom End) .....\$84.60
- Fits '16~'17 YZ450FX*  
**1SL-W0001-00-00** (Top End) .....\$51.52
- Fits '17 YZ450FX*  
**26C-W0002-00-00** (Bottom End) .....\$76.46
- Fits '16 YZ450FX*  
**2S2-W0002-00-00** (Bottom End) .....\$61.76
- Fits '14~'16 YZ450F*  
**1SL-W0001-00-00** (Top End) .....\$51.52  
**1SL-W0002-00-00** (Bottom End) .....\$61.76
- Fits '10~'13 YZ450F*  
**33D-W0001-00-00** (Top End) .....\$87.12  
**33D-W0002-00-00** (Bottom End) .....\$77.75
- Fits '06~'09 YZ450F*  
**2S2-W0001-10-00** (Top End) .....\$69.99  
**2S2-W0002-10-00** (Bottom End) .....\$59.95
- Fits '03~'05 YZ450F*  
**5TA-W0001-00-00** (Top End) .....\$100.99  
**5TG-W0002-00-00** (Bottom End) .....\$100.99



D



E



F

**F. GYTR® TWO-STAGE FOAM AIR FILTER**

High-flow, two-layer foam filter offers optimized filtration while maximizing airflow. Increases performance. Filter is completely washable and reusable. Service with Yamaha Genuine Foam Filter Oil. This accessory is restricted to closed-course use.

- Fits '05~'09 YZ450F*  
**GYT-4EW95-00-00** .....\$32.49

COVERS

GRAPHICS

HANDLEBARS & CONTROLS

PERFORMANCE

PROTECTION

SEATS

SPROCKETS & CHAINS

TRIM & ACCENTS

WHEELS

**COVERS**

**GRAPHICS**

**HANDLEBARS & CONTROLS**

**PERFORMANCE**

**PROTECTION**

**SEATS**

**SPROCKETS & CHAINS**

**TRIM & ACCENTS**

**WHEELS**

**A. PRE-FILTER BY OUTERWEARS®**

Offers less maintenance in dusty conditions and pre-filters dirt. No critical airflow restriction or power loss. Works with Yamaha OEM Air Filter or GYTR Air Filter.

*Fits '06~'09 YZ450F*  
**GYT-OSS56-31-85** .....\$22.49



**A**

**B. GYTR® BY FMF® MEGABOMB® HEAD PIPE**

The full titanium construction MegaBomb® header can provide as much as a 3 hp boost, plus the MegaBomb® actually reduces noises levels by as much as 1.5 dBA. The MegaBomb® is designed to perform at the world's highest levels of racing. The MegaBomb® produces long header torque and short header over-rev. Made from premium titanium material. This accessory is restricted to closed-course use.

*Fits '14~'17 YZ450F; '16~'17 YZ450FX*  
**1SL-E46A0-T0-00** (Stainless Steel).....\$357.99  
**1SL-E46A0-V0-00** (Titanium) (Shown) .....\$449.99



**B**

**C. GYTR® BY FMF® POWERBOMB® HEAD PIPE**

The Stainless Steel PowerBomb® is a four-stroke header that incorporates the patented PowerBomb® module at a precise location in the initial stage of the header. By positioning this "Bomb" at a key point in the system, increased performance and flow is achieved through the expansion and contraction of exhaust sonics through the system. The result is a flow increase of nearly 10%! The outer chamber in the PowerBomb® allows the air to expand, cool, and ramp back up at a higher velocity. Additionally, the PowerBomb® is a "pre-muffler" of sorts, which helps to lower the bike's sound output by providing more sound absorbing surface area for the sound medium (exhaust gases). The PowerBomb® provides power focused in the mid to upper rpm range. This accessory is restricted to closed-course use.

*Fits '07~'09 YZ450F*  
**2S2-E46A0-V0-00** (Stainless Steel) .....\$199.99



**C**

**D. GYTR® BY FMF® ALUMINUM POWERCORE® 4 HEX MUFFLER**

The PowerCore®4 is designed to increase the horsepower and torque throughout the entire power curve and give you a noticeable power increase that is very usable and beneficial, no matter your riding style or ability. Features include space age internal packing for maximum packing life and a high-flow modular end cap. Internal core shape uses high-flow technology. Enhanced sonic evacuation provides for higher flow and increased power. Muffler includes removable spark arrestor. 97.5 dBA sound level. 95.5 dBA with QuietCore™ Spark Arrestor Insert, sold separately. This accessory is restricted to closed-course use. Head Pipe not included.

*Fits '14~'17 YZ450F; '16~'17 YZ450FX*  
**1SL-E47A0-T0-00** (Aluminum).....\$336.99

*Fits '10~'13 YZ450F*  
**33D-E47A0-T1-00** (Aluminum) .....\$329.99

*Fits '09 YZ450F*  
**2S2-E47A0-V1-00** (Aluminum) .....\$336.99



**D**

**E. GYTR® BY FMF® TITANIUM RCT FACTORY 4.1™ MUFFLER**

The patented FMF® Resonance Chamber Technology enhances and refines exhaust pressure. Its patented core shape lowers sound level while maintaining maximum power output, and the patented canister shape increases internal volume for more sound-absorbing material. Factory Forward Engineering centralizes mass and is less prone to impact damage. Maintenance is easy remove four screws on the front end cap, and the innovative rear end cap simplifies the installation of the spark arrestor (sold separately) or tuning tip inserts. Includes QuietCore 94 dBA insert. Meets AMA® and FIM sound requirements. This muffler is used by factory-supported teams. It is compatible with stock or FMF® header and made in the U.S.A. This accessory is restricted to closed-course use. Head Pipe not included.

*Fits '14~'17 YZ450F; '16~'17 YZ450FX*  
**1SL-E47A0-V0-00**.....\$612.99



**E**



A



B



C



D



E



F



G



H

**A. GYTR® BY FMF® FACTORY 4.1™ MUFFLER**

Factory 4.1™ Muffler incorporates the latest FMF® Resonance Chamber Technology. The patented chamber design enhances and refines exhaust pressure. Its patented core shape lowers sound level while maintaining maximum power output, and the patented canister shape increases internal volume for more sound-absorbing material. Factory Forward Engineering centralizes mass and is less prone to impact damage. Maintenance is made easy with the removal of four screws on the front end cap, and the innovative rear end cap simplifies installation of the spark arrestor (sold separately) or tuning tip inserts. Includes QuietCore™ 94 dBA insert. Meets AMA® and FMF sound requirements. Compatible with stock or FMF® header. Built 100% in the U.S.A. This accessory is restricted to closed-course use.

- Fits '10~'13 YZ450F*  
**33D-E47A0-S0-00**.....\$449.99
- Fits '06~'09 YZ450F*  
**2S2-E47A0-T0-00** (Shown).....\$499.99

**B. GYTR® BY FMF® REPLACEMENT SPARK ARRESTOR INSERT**

The GYTR by FMF® Replacement Spark Arrestor Insert is designed to fit the GYTR by FMF® PowerCore®4 Mufflers.

- Fits '09~'17 YZ450F*  
**33D-E46C0-V0-00**.....\$30.99

**C. GYTR® BY FMF® QUIETCORE™ SPARK ARRESTOR INSERT**

Noise-reducing inserts with spark arrestors. YZ models are for closed-course use regardless of modification.

- Fits '10~'17 YZ450F; '16~'17 YZ450FX*  
**33D-E46C0-T0-00**.....\$30.99

**D. REPLACEMENT MUFFLER CLAMP**

A replacement muffler clamp for the GYTR Stainless Steel Exhaust System.

- Fits '06~'09 YZ450F*  
**GYT-2S293-28-00**.....\$13.99

**E. GYTR® BILLET PRESSURE PLATE**

Precision-machined from the highest grade of aluminum, then hard anodized to achieve an exceptionally hard, wear-resistant surface for amazing race-proven durability. Additional oil passages help improve clutch performance and also contribute to a 30% weight reduction and less rotational mass for improved acceleration.

- Fits '07~'17 YZ450F*  
**GYT-2S256-20-00**.....\$164.99
- Fits '03~'06 YZ450F; '16~'17 YZ450FX*  
**GYT-5XD56-20-00**.....\$169.99

**F. GYTR® BILLET CLUTCH INNER HUB**

Precision machined from the highest grade of aluminum, then hard anodized to achieve an exceptionally hard, wear-resistant surface for amazing race-proven durability. Additional oil passages help improve clutch performance and contribute to a 20% weight reduction and less rotational mass for improved acceleration.

- Fits '05~'17 YZ450F; '16~'17 YZ450FX*  
**GYT-5XD56-40-00**.....\$297.99

**G. GYTR® BILLET CLUTCH BASKET**

Precision machined from the highest grade of aluminum and then anodized to achieve an exceptionally hard, wear-resistant surface. This clutch basket provides amazing, race-proven durability.

- Fits '05~'17 YZ450F; '16~'17 YZ450FX*  
**GYT-5XD56-10-00**.....\$226.99

**H. GYTR® BILLET CLUTCH COVER**

Precision-machined from the highest grade of aluminum and then anodized to achieve an exceptionally hard, wear-resistant surface.

- Fits '10~'17 YZ450F; '16~'17 YZ450FX*  
**33D-E54E0-V0-00**.....\$148.99
- Fits '08~'09 YZ450F*  
**GYT-5XD35-10-AL**.....\$148.99

COVERS

GRAPHICS

HANDLEBARS & CONTROLS

PERFORMANCE

PROTECTION

SEATS

SPROCKETS & CHAINS

TRIM & ACCENTS

WHEELS

**COVERS**

**GRAPHICS**

**HANDLEBARS & CONTROLS**

**PERFORMANCE**

**PROTECTION**

**SEATS**

**SPROCKETS & CHAINS**

**TRIM & ACCENTS**

**WHEELS**

**A. YAMAHA GENUINE OFF-ROAD CLUTCH KIT**

These complete Yamaha Clutch Kits include the plates, springs, and gaskets, ready to install. Refer to service manual for installation instructions.

<i>Fits '16~'17 YZ450FX</i> <b>2GC-W001G-00-00</b> .....	<b>\$164.99</b>
<i>Fits '14~'17 YZ450F</i> <b>1SL-W001G-00-00</b> .....	<b>\$151.56</b>
<i>Fits '11~'13 YZ450F</i> <b>33D-W001G-10-00</b> .....	<b>\$161.99</b>
<i>Fits '10 YZ450F</i> <b>33D-W001G-00-00</b> .....	<b>\$161.99</b>
<i>Fits '07~'09 YZ450F</i> <b>2S2-W001G-10-00 (Shown)</b> .....	<b>\$167.99</b>

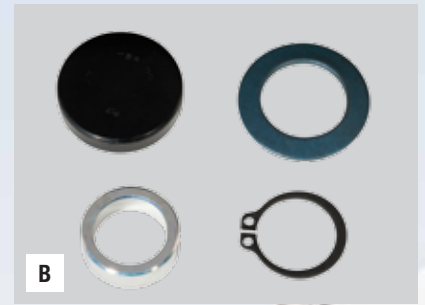

**B. GYTR® KICK START REMOVAL KIT**

Allows customer to remove the kick start lever, shaft, and gear. Kick Start lever can always be re-installed on the bike at a later date, if desired.

<i>Fits '16~'17 YZ450FX</i> <b>B91-E57A0-V0-00</b> .....	<b>\$30.99</b>
---	----------------



**C. GYTR® POWER TUNER**

This easy plug-in fuel-injection and ignition tuning tool allows riders to quickly adjust the fuel and ignition maps to suit riding conditions and rider preference. Allows nine easy-to-program adjustment points for both the fuel and ignition maps. Monitor function allows user to monitor the data from various sensors on the bike as well as adjust idle timing, see engine running time, and self-diagnosis function. Powered by two AA batteries, thus no laptop or time consuming downloads necessary. Unit does not have to be plugged into bike to create maps. Compact design can fit in the palm of your hand, pocket, etc. Memory function can save up to nine custom maps.

**NOTE:** Plugs right into the YZ450F, YZ450FX, YZ250FX, and YZ250F ECU. WR450F and WR250F require GYTR Competition Kit/ECU, sold separately.

<i>Fits '10~'17 YZ450F; '16~'17 YZ450FX</i> <b>33D-H59C0-V1-00</b> .....	<b>\$298.99</b>
---	-----------------

**D. RADIATOR FAN KIT**

This radiator fan kit adds a cooling fan to the right side radiator, increasing the overall cooling capability. Good for tight, muddy riding conditions and competition. Easy installation, motorcycle is already pre-wired for plug-and-play. No modifications necessary. YZ models are for closed-course use regardless of modification.

<i>Fits '16~'17 YZ450FX</i> <b>B29-E24E0-V0-00</b> .....	<b>\$72.99</b>
---	----------------



**E. OVERSIZED FUEL TANKS BY IMS**

These tanks are designed to carry more fuel and enhance the appearance of your motorcycle. Larger capacity than stock, yet very slim and sleek. Provides greater riding distance per full tank. Perfect for races where the extra distance can mean the difference between winning and losing. These tanks are made with Polyethylene Crosslink for extra strength and durability. Suitable only for closed-course competition.

<i>Fits '14~'17 YZ450F</i> <b>DBY-ACC56-34-62 (Natural) (2.9 gal) (Shown)</b> .....	<b>\$274.99</b>
<i>Fits '17 YZ450FX</i> <b>DBY-ACC56-34-81 (Black) (3.0 gal)</b> .....	<b>\$274.99</b>
<i>Fits '16 YZ450FX</i> <b>DBY-ACC56-34-82 (Black) (3.0 gal) (Shown)</b> .....	<b>\$274.99</b>
<b>DBY-ACC56-34-83 (Natural) (3.0 gal)</b> .....	<b>\$274.99</b>





A

**A. HAMMERHEAD™ ROCKET LAUNCHER HOLESHOT DEVICE**

The #1 problem with most holeshot devices is failure due to the push pin getting kinked and locked in the sides of the soft aluminum catch slot built into the fork strap. This is a result of the pressure pulling the pieces apart and the hard steel pin crushing and deforming the soft aluminum button body and fork strap. With these old designs, it is not a matter of if, but when, you will have a failure that could cost you a race and possibly much more. With the new-design Hammerhead™ Rocket Launcher, your holeshot is guaranteed.

*Fits '06~'17 YZ450F; '16~'17 YZ450FX*

- DBY-ACC56-33-08 (Black)**.....\$102.95
- DBY-ACC56-33-09 (Blue)**.....\$102.95



B



C

**B. YAMAHA GENUINE FRONT FORK SEAL KITS**

These Yamaha Genuine Fork Seal Kits come with the original equipment fork and dust seals. Don't settle for the next best thing from the aftermarket use Yamaha Genuine Fork Seal Kits for longer life and less maintenance. Don't forget to order the proper fork oil for your bike, as well. Yamaha Fork Oils are formulated specifically for your model and deliver the highest suspension performance possible.

*Fits '10~'17 YZ450F; '16 YZ450FX*

- 17D-W003B-00-00**.....\$67.99

*Fits '04~'09 YZ450F*

- 1C3-W003B-00-00**.....\$67.99

*Fits '99~'03 YZ450F*

- 5ET-W003B-00-00**.....\$62.99



D

**C. YAMAHA GENUINE BEARING KITS**

These Yamaha Genuine Bearing Kits come with all of the components needed to rebuild the swingarm pivot, shock linkage, and shock bearings. Kits include all of the original equipment bearings, seals, O-rings, and collars your bike came with. Unlike some of the aftermarket companies that use a lower quality bearing, these bearings are O-ring sealed to prevent intrusion of dirt, mud, and water and are made of top quality materials. If you don't want to do the job again and in half the time your original bearings lasted, use these Yamaha Genuine kits.

*Fits '07~'16 YZ450F; '16 YZ450FX*

- 1SS-W002G-00-00 (Shock)**.....\$77.99

*Fits '06 YZ450F*

- 1C3-W002G-00-00 (Shock)**.....\$62.99

*Fits '10~'17 YZ450F; '16~'17 YZ450FX*

- 33D-W002C-00-00 (Swingarm)**.....\$81.99

*Fits '06~'09 YZ450F*

- 1HC-W002C-00-00 (Swingarm)**.....\$81.99

*Fits '09~'17 YZ450F; '16~'17 YZ450FX*

- 33D-W002E-00-00 (Linkage)**.....\$89.99

*Fits '06~'08 YZ450F*

- 1HC-W002E-00-00 (Linkage)**.....\$89.99

**D. GYTR® STAINLESS STEEL BRAIDED BRAKE LINE KIT**

These top-quality brake lines are designed to not fatigue even under extreme conditions.

*Fits '10~'17 YZ450F*

- 17D-F58E0-V0-00 (Front)(Shown)**.....\$66.99

*Fits '09~'17 YZ450F; '16~'17 YZ450FX*

- 5XC-F58A0-V0-00 (Rear)**.....\$61.99

*Fits '08~'09 YZ450F*

- 5XC-F58E0-V0-00 (Front)**.....\$73.99

**E. GYTR® BY BRAKING™ SOLID REAR BRAKE ROTOR**

The GYTR by BRAKING™ Solid Rear Brake Rotor is a high quality, durable, slot-less brake rotor that helps extend brake pad life in muddy conditions.

*Fits '03~'17 YZ450F; '16~'17 YZ450FX*

- 1SL-F58G0-V0-00**.....\$107.99



E

COVERS

GRAPHICS

HANDLEBARS & CONTROLS

PERFORMANCE

PROTECTION

SEATS

SPROCKETS & CHAINS

TRIM & ACCENTS

WHEELS

**COVERS**

**GRAPHICS**

**HANDLEBARS & CONTROLS**

**PERFORMANCE**

**PROTECTION**

**SEATS**

**SPROCKETS & CHAINS**

**TRIM & ACCENTS**

**WHEELS**

**A. BATFLY 270 OVERSIZED ROTOR KIT**

The 270mm Batfly is the natural evolution of the popular BRAKING™ design profile and is easily recognizable thanks to the black grooves that are cut across the outer braking track resembling bat wings, hence the name “Batfly.” The new version features a new carrier that has been 100% heat treated and redesigned for strength as well as a redesign of the outer profile and grooves for a trick new look. With the larger 270mm diameter, maximum braking power is obtained, but with the Batfly design, brake feeling is increased even further, achieving the perfect combination of stopping power and brake feel. BRAKING®’s Batfly profile maintains the lowest temperature possible in race conditions, resulting in a better progression in brake feeling than any other oversized rotor kit available. Kit includes 270mm oversized Batfly design rotor, caliper relocation bracket, and a set of CM46 Sintered Race series pads.

*Fits '08~'13 YZ450F*  
**GYT-OSS56-30-63** .....\$354.95

**B. FORK BLEEDERS BY MOTION PRO®**

The Fork Bleeders by Motion Pro® features:

- Releases trapped air in forks with push of a button
- Small unobtrusive profile
- Installs in minutes
- Fits any bike with a 5mm x 0.08 thread pitch

*Fits '09~'17 YZ450F; '16~'17 YZ450FX*  
**DBY-ACC56-34-66** .....\$15.99

**C. GYTR® PLASTIC CHAIN GUIDE**

This ultra-durable UHMWPE plastic guide is designed to flex, not bend, in the event of impact.

*Fits '07~'17 YZ450F; '16~'17 YZ450FX*  
**17D-F21E0-V0-00 (Black)** .....\$88.99

**D. GYTR® RADIATOR CAGES**

Full cage with rod design and constructed with stamped 3.2mm aluminum to provide strength and protection in the event of side impacts. Easy-to-install design means radiator removal is not required.

*Fits '14~'17 YZ450F*  
**1SL-E24C0-T0-S0** .....\$109.95

*Fits '16~'17 YZ450FX*  
**2GB-E24C0-V0-00** .....\$133.99

**E. GYTR® RADIATOR BRACES**

Constructed of lightweight aluminum for an optimized strength-to-weight ratio. Thinner and lighter material is possible due to the rolled edges that provide extra strength. Structural ribs run along the sides of the braces to limit radiator damage from side impact. All required mounting hardware included. No trimming of the plastics is required to install.

*Fits '10~'13 YZ450F*  
**33D-E24C0-V0-00** .....\$107.95

*Fits '14~'17 YZ450F*  
**1SL-E24C0-V0-00 (Shown)** .....\$107.99



**A**



**B**



**C**



**D**



**E**



A

**A. YAMAHA GENUINE REPLACEMENT SIDE COVERS**

The Yamaha Genuine Replacement Side Covers are sold as a pair. Yamaha Genuine replacements for the stock covers (graphics not included). Less expensive than purchasing stock covers that use a very expensive inlay process for the graphics. Includes metal collars.

*Fits '14-'17 YZ450F*  
**1SL-W003D-00-00 (White)** .....\$99.99

**B. POWERFLOW INTAKE SHROUDS BY CYCRA®**

Patented Cycra® Powerflow technology dramatically reduces radiator, fuel tank, and engine head temperatures. Integration of forced air inlets into the airbox cover allows additional air intake and eliminates the need to drill holes. Scoops allow more air into the airbox for added performance. Airbox cover mates to the Powerflow shrouds for complete system. Narrows the space between the rider's leg and knee area for better ergonomics. Leading edge is "tucked in" to prevent boot snag.

*Fits '14-'17 YZ450F; '16-'17 YZ450FX*  
**DBY-ACC56-34-74 (Black)** .....\$124.99  
**DBY-ACC56-34-75 (White)** .....\$124.99  
**DBY-ACC56-34-76 (Blue)** .....\$124.99

**C. PLASTIC BODY KITS BY CYCRA®**

Powerflow Intake Race Systems dramatically decreases operating temperatures with by-pass airflow technology that maximizes cooling efficiency. Injection-molded precise fit and high gloss finish. Kit includes: Powerflow Intake Radiator Shrouds, Performance Front Fender, Powerflow Rear Fender, Stadium Number Plate, Side Number Panels, Airbox Cover, and Fork Guards. Used by top level racing teams.

*Fits '14-'17 YZ450F*  
**DBY-ACC56-34-77 (Blue/ White)** .....\$257.99  
**DBY-ACC56-34-78 (Black)** .....\$257.99  
**DBY-ACC56-34-79 (White)** .....\$257.99  
**DBY-ACC56-34-78 (Blue)** .....\$257.99



B



C

COVERS

GRAPHICS

HANDLEBARS & CONTROLS

PERFORMANCE

PROTECTION

SEATS

SPROCKETS & CHAINS

TRIM & ACCENTS

WHEELS

**COVERS**

**GRAPHICS**

**HANDLEBARS  
& CONTROLS**

**PERFORMANCE**

**PROTECTION**

**SEATS**

**SPROCKETS  
& CHAINS**

**TRIM &  
ACCENTS**

**WHEELS**

**A. QUICK-RELEASE AIR BOX HARDWARE KIT**

This kit provides speedy removal of the air box cover and easy access to the air filter. Replaces all three stock air box cover bolts with quarter-turn Dzus® fasteners. Four fasteners are included with the kit.

*Fits '14~'15 YZ450F*  
**1SL-E54G0-V0-00** .....\$26.99



**B. GYTR® MX GLIDE PLATE**

The GYTR MX Glide Plate is constructed of 4mm composite. The MX Glide Plate is a flexible, lightweight and low drag coefficient alternative to aluminum glide plates when needing a smooth surface for “gliding” over obstacles. It can be used in conjunction with stock water pump cover or GYTR Water Pump Guard.

*Fits '14~'17 YZ450F*  
**1SL-F14B0-S0-00** .....\$128.99



**C. ENDURO™ SKID PLATE**

This aluminum plate is designed with side skirts to help protect the lower frame rails, critical engine components, water pump, ignition cover, and clutch components even on the gnarliest enduro course.

*Fits '14~'17 YZ450F*  
**1SL-F14B0-V0-00** .....\$140.95



**D. GYTR® ALUMINUM SKID PLATE**

This aluminum plate is designed with side skirts to help protect the lower frame rails, critical engine components, water pump, ignition cover, and clutch components even on the gnarliest enduro course.

*Fits '16~'17 YZ450FX*  
**2GB-F14B0-V0-00** .....\$128.99

**E. ENDURO™ ALUMINUM SKID PLATE**

This aluminum plate is designed with side skirts to help protect the lower frame rails, critical engine components, water pump, ignition cover, and clutch components even on the gnarliest enduro course.

*Fits '10~'13 YZ450F*  
**33D-F14B0-T0-00** .....\$132.95

**F. GYTR® REAR BRAKE MASTER CYLINDER GUARD**

This guard helps protect the rear brake master cylinder from possible damage and provides more surface for rider feel.

*Fits '10~'13 YZ450F*  
**33D-F58C0-V0-00** .....\$35.95



**G. WATER PUMP GUARD**

This lightweight 4mm composite guard replaces the stock plastic guard for added protection to the right side engine components and lower drag coefficient. It will flex and not bend during an impact and can be used alone or with GYTR MX Glide Plate. (Shown with optional skid plate here.)

*Fits '14~'17 YZ450F*  
**1SL-F14C0-V0-00** .....\$51.99





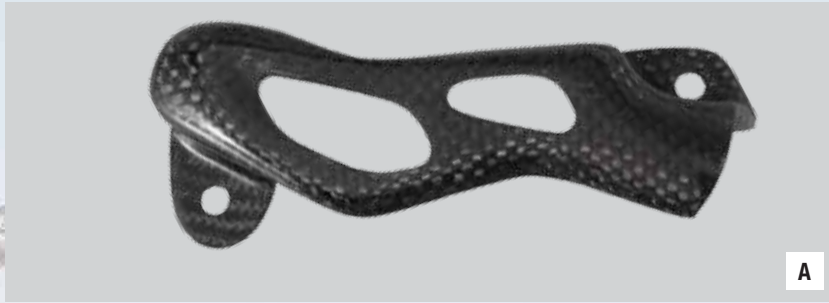

A

**A. CARBON FIBER REAR CALIPER GUARD BY LIGHTSPEED®**

Durable, lightweight carbon fiber design helps protect your rear brake caliper.

*Fits '06~'17 YZ450F*  
**GYT-OSS56-30-27** .....\$46.95



B

**B. GYTR® PLASTIC REAR BRAKE GUARD**

The GYTR Rear Brake Disc Guard is made of ultra-durable UHMWPE (Ultra High Molecular Weight Polyethylene). This disc guard is designed to flex and not bend upon impact. Improved durability in gnarly off-road conditions. Machined collars and OE style hardware allows for easy, same tool installation.

*Fits '06~'17 YZ450F; '16~'17 YZ450FX*  
**1DX-F58FO-V0-00** .....\$112.99



C



D

**C. CARBON FIBER REAR CALIPER GUARD & DISC GUARD SET BY LIGHTSPEED®**

This kit includes carbon fiber components that will help protect the rear brake disc and caliper. Sold as a set.

*Fits '06~'17 YZ450F*  
**GYT-OSS56-30-28** .....\$97.95

**D. CARBON FIBER FRONT DISC GUARD BY LIGHTSPEED®**

Carbon fiber construction provides the ultimate combination of a lightweight yet super strong part. Directional venting aids heat reduction, reducing brake fade. Kevlar® reinforcement patch placed in strategic areas to aid in durability. Helps protect the front brake disc. Will work on oversized brake rotors up to 295mm.

*Fits '06~'13 YZ450F*  
**GYT-OSS56-30-29** .....\$108.49

**E. CARBON FIBER RIGHT-HAND FORK LUG COVER BY LIGHTSPEED®**

This lightweight, functional cover protects the fork lug and rebound clicker while acting as a small glide plate to prevent "hang ups" in ruts.

*Fits '08~'13 YZ450F*  
**GYT-OSS56-32-54** .....\$72.95



E

**F. YAMAHA SHORT SEAT**

Shorter than the stock seat (slightly under 1" shorter). Fully assembled seat assembly with gripper seat cover. Great for shorter riders. Helps hold rider in seated position. Simple installation and removal.

*Fits '14~'17 YZ450F; '16~'17 YZ450FX*  
**B11-F47C0-T0-00** .....\$133.99



F

**G. YAMAHA TALL SEAT**

Taller than the stock seat (slightly under 1" taller). Fully assembled seat assembly with gripper seat cover. Great for taller riders. Helps hold rider in seated position. Simple installation and removal.

*Fits '14~'17 YZ450F; '16~'17 YZ450FX*  
**B11-F47C0-V0-00** .....\$133.99



G

COVERS

GRAPHICS

HANDLEBARS & CONTROLS

PERFORMANCE

PROTECTION

SEATS

SPROCKETS & CHAINS

TRIM & ACCENTS

WHEELS

**COVERS**

**GRAPHICS**

**HANDLEBARS & CONTROLS**

**PERFORMANCE**

**PROTECTION**

**SEATS**

**SPROCKETS & CHAINS**

**TRIM & ACCENTS**

**WHEELS**

**A. GYTR® REAR SPROCKETS**

These GYTR Rear Sprockets are made from 7075-T6 billet aluminum CNC-machined for maximum fit accuracy. Features a radial mud groove etched just inside the sprocket teeth to shed mud and grit which saves weight and increases chain life. Sprocket sizes other than stock are for closed-course competition only on '06 and later off-road models and all street legal models. Changing the final drive ratio affects exhaust emissions and also affects speedometer readings.

*Fits '03-'17 YZ450F; '16-'17 YZ450FX*

<b>GYT-75339-47-BK</b> (Black, 47T) .....	<b>\$61.95</b>
<b>GYT-75339-47-BL</b> (Blue, 47T) .....	<b>\$62.49</b>
<b>GYT-75339-48-BK</b> (Black, 48T) .....	<b>\$62.49</b>
<b>GYT-75339-48-BL</b> (Blue, 48T) .....	<b>\$62.49</b>
<b>GYT-75339-48-MG</b> (Gold, 48T) .....	<b>\$61.95</b>
<b>GYT-75339-49-BK</b> (Black, 49T) .....	<b>\$62.49</b>
<b>GYT-75339-49-BL</b> (Blue, 49T) .....	<b>\$62.49</b>
<b>GYT-75339-49-MG</b> (Gold, 49T) .....	<b>\$62.49</b>
<b>GYT-75339-50-BK</b> (Black, 50T) .....	<b>\$62.49</b>
<b>GYT-75339-50-BL</b> (Blue, 50T) .....	<b>\$62.49</b>
<b>GYT-75339-50-MG</b> (Gold, 50T) .....	<b>\$62.49</b>
<b>GYT-75339-51-BK</b> (Black, 51T) .....	<b>\$62.49</b>
<b>GYT-75339-51-BL</b> (Blue, 51T) .....	<b>\$62.49</b>
<b>GYT-75339-51-MG</b> (Gold, 51T) .....	<b>\$61.95</b>
<b>GYT-75339-52-BK</b> (Black, 52T) .....	<b>\$61.95</b>
<b>GYT-75339-52-BL</b> (Blue, 52T) .....	<b>\$62.49</b>
<b>GYT-75339-52-MG</b> (Gold, 52T) .....	<b>\$61.95</b>
<b>GYT-75339-53-BK</b> (Black, 53T) .....	<b>\$61.95</b>
<b>GYT-75339-53-BL</b> (Blue, 53T) .....	<b>\$61.95</b>

**A**

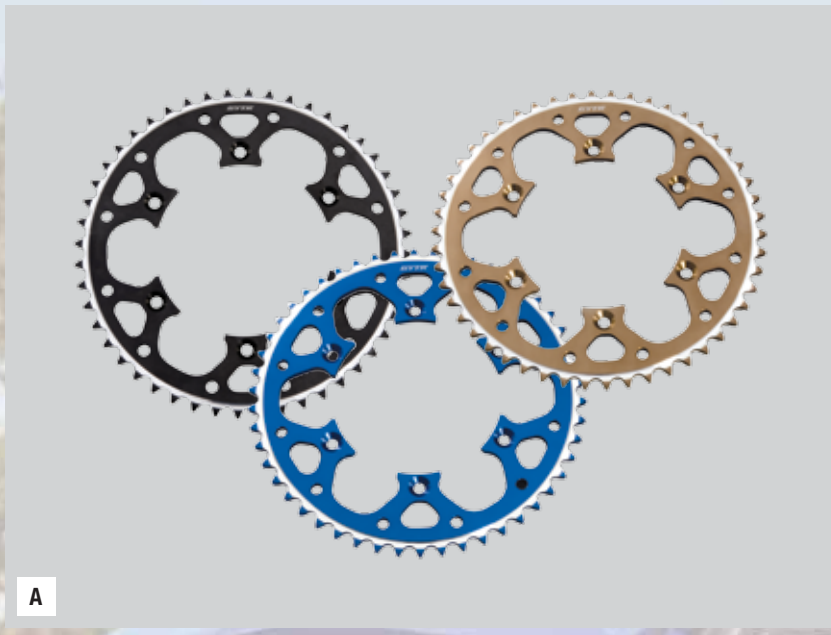

**B. GYTR® FRONT SPROCKETS BY TALON®**

Made from heat-treated chromoly steel and CNC-machined to extremely high tolerances. Zinc finish to help combat corrosion. Sprockets feature self-cleaning grooves to shed mud and grit, as well as reduce weight while maintaining strength. Sprocket sizes that increase the final drive ratio over stock are for closed-course competition only on '06 and later models because regulated exhaust emissions are affected.

*Fits '06-'17 YZ450F; '16-'17 YZ450FX*

<b>GYT-75439-13-00</b> (Silver, 13T) .....	<b>\$26.49</b>
<b>GYT-75439-14-00</b> (Silver, 14T) .....	<b>\$26.49</b>

**B**



**C. GYTR® ULTRA-HIGH PERFORMANCE RACING CHAINS BY EK®**

GYTR Ultra-High Performance Racing Chains & Links by EK® offer the ultimate balance of performance and durability for various applications. Chains will not work on vehicles with a shaft drive.

**520 GDO(2) O-Ring Chain:**

- Displacement Limit: Up to 650cc
- Tensile strength = 8,000 lb
- 120 links
- Manufactured by the inventor of the world's first O-ring
- Ideal for small and mid-sized off-road motorcycles, sportbikes, and ATVs
- Includes clip and rivet type master link

<b>GYT-ACC56-20-05</b> (Gold, 520 GDO2 O-Ring Chain).....	<b>\$84.99</b>
<b>GYT-ACC56-20-22</b> (Gold, 520 GDO2 Clip Type Master Link) ..	<b>\$5.99</b>
<b>GYT-ACC56-20-06</b> (Gold, 520 GDO2 Rivet Type Master Link) ..	<b>\$3.49</b>
<b>GYT-ACC56-20-07</b> (Natural, 520 GDO2 O-Ring Chain) .....	<b>\$74.99</b>
<b>GYT-ACC56-20-23</b> (Natural, 520 GDO2 Clip Type Master Link) .....	<b>\$5.99</b>
<b>GYT-ACC56-20-08</b> (Natural, 520 GDO2 Rivet Type Master Link) .....	<b>\$3.49</b>

**520 GMX2 Non-Sealed (Non O-Ring) Chain:**

- Displacement Limit: Up to 500cc
- Tensile strength = 8,400 lb
- 120 links
- Specifically designed for Motocross and Supercross
- Race-tested by Factory Riders to meet today's high performance machines
- High-tech CrH-coated pins for extremely hard outside surface and softer inside to increase the impact strength
- Includes clip and rivet type master link

<b>GYT-ACC56-20-09</b> (Gold, 520 GMX2 Non O-Ring Chain) .....	<b>\$96.49</b>
<b>GYT-ACC56-20-18</b> (Gold, 520 GMX2 Rivet Type Master Link) ..	<b>\$3.99</b>
<b>GYT-ACC56-20-10</b> (Gold, 520 GMX2 Clip Type Master Link) ..	<b>\$2.99</b>
<b>GYT-ACC56-20-11</b> (Natural, 520 GMX2 Non O-Ring Chain) ..	<b>\$87.49</b>
<b>GYT-ACC56-20-17</b> (Natural, 520 GMX2 Rivet Type Master Link) .....	<b>\$3.99</b>
<b>GYT-ACC56-20-12</b> (Natural, 520 GMX2 Clip Type Master Link) .....	<b>\$2.99</b>

**C**





A



B

**A. GYTR® REAR BRAKE CLEVIS**

This billet rear brake clevis is machined to extremely tight tolerances which minimizes lateral movement or vibration of the rear brake pedal. This clevis allows for more height adjustment and features a titanium clevis pin that is half the weight of stock.

*Fits '09-'17 YZ450F; '16-'17 YZ450FX*  
**5XC-F72A0-V0-00** (Blue).....\$50.99

**B. GYTR® BRAKE LINE PINCH**

This pinch replaces the stock steel pinch with a blue anodized billet aluminum piece.

*Fits '06-'17 YZ450F*  
**GYT-1P818-15-00** (Blue) .....\$40.99



C

**C. GYTR® MAGNETIC OIL DRAIN PLUG**

Replace the stock steel drain plug with this 6061 billet Magnetic Oil Drain Plug. 60% lighter than stock. Includes a magnet that collects metal shavings, preventing them from circulating in the motor oil. Used by Yamaha Racing Teams.

*Fits '14-'17 YZ450F; '16-'17 YZ450FX,*  
**18P-E51C0-U0-00** (Red) .....\$32.99

**D. GYTR® 36MM TIMING PLUG**

These anodized 6061 billet aluminum timing plugs replace the stock plastic plugs.

*Fits '10-'17 YZ450F; '16-'17 YZ450FX*  
**33D-E51A0-T0-00** (Black) (Shown) .....\$38.99  
**33D-E51A0-V0-00** (Blue) .....\$38.99



D



E

**E. GYTR® 27MM TIMING PLUG**

These anodized 6061 billet aluminum timing plugs replace the stock plastic plugs.

*Fits '08-'09 YZ450F*  
**GYT-2S235-27-AL** (Blue) .....\$28.95



F

**F. GYTR® 14MM TIMING COVER PLUG**

These anodized 6061 billet aluminum timing plugs replace the stock plastic plugs.

*Fits '10-'17 YZ450F; '16-'17 YZ450FX*  
**18P-E51B0-V0-00** (Red) .....\$30.95  
**5XC-E51B0-V0-00** (Black) .....\$30.99  
**GYT-2S235-14-AL** (Blue) .....\$28.99

**G. GYTR® BILLET OFFSET AXLE BLOCKS**

These billet aluminum soft anodized axle blocks are reversible and offset and keep the adjustment bolts from extending too far back when running the rear wheel toward the back of the swingarm for maximum wheelbase.

*Fits '10-'17 YZ450F*  
**33D-F53M0-T0-00** (Black) .....\$50.99  
**33D-F53M0-V0-00** (Blue) (Shown) .....\$50.99  
*Fits '17 YZ450FX*  
**GYT-2S299-10-00** (Blue) .....\$47.99



G

COVERS

GRAPHICS

HANDLEBARS & CONTROLS

PERFORMANCE

PROTECTION

SEATS

SPROCKETS & CHAINS

TRIM & ACCENTS

WHEELS

**COVERS**

**GRAPHICS**

**HANDLEBARS & CONTROLS**

**PERFORMANCE**

**PROTECTION**

**SEATS**

**SPROCKETS & CHAINS**

**TRIM & ACCENTS**

**WHEELS**

**A. YAMAHA KICKSTAND**

- Allows rider to distance themselves from the bike without a prop of some sort (tree, fence, rock, etc)
- Replaces the left side foot peg bracket
- Same kickstand that comes standard on WR models, so you know you're getting a quality Yamaha factory part
- Durable aluminum construction with a secure attachment; doesn't clamp to the swingarm like other comparable products
- Lighter weight than other aftermarket options

*Fits '14-'17 YZ450F*  
**B11-F73A0-V0-00** ..... **\$144.99**



**B. YAMAHA KICKSTAND REMOVAL KIT (PEG MOUNT)**

Allows rider to remove the stock kickstand. Kit replaces the left side foot peg bracket. Kit includes the same components that come standard on YZ four-stroke models. The durability and quality you expect from Yamaha Genuine Parts.

*Fits '16-'17 YZ450FX*  
**B91-F73A0-V0-00** ..... **\$25.99**

**C. NEW! YAMAHA GENUINE KICK STARTER KIT**

This complete Kick Starter Kit includes all the components and gaskets needed to add kick start functionality to your 2017 YZ450FX.

- Includes necessary OE parts
- Dealer installation recommended

*Fits '17 YZ450FX*  
**B91-15602-00-00** ..... **\$224.95**



**D. 21" FRONT WHEEL ASSEMBLY**

These complete original-equipment wheel assemblies are available for Yamaha YZ & WR models. Wheels are factory assembled, ready for installation, and come complete with hub assemblies, spoke sets, rim locks, wave-style brake rotors, and oil seals. Front and rear assemblies are sold separately.

*Fits '14-'17 YZ450F*  
**1SL-25102-00-00 (Silver) (Shown)** ..... **\$334.99**  
**1SL-25102-10-00 (Black)** ..... **\$360.99**

*Fits '02-'13 YZ450F*  
**5XC-W2519-L0-00 (Silver)** ..... **\$345.99**



**E. YAMAHA GENUINE OFF-ROAD 19" REAR WHEEL ASSEMBLIES\***

Wheels are factory assembled, ready for installation, and come complete with hub assemblies, spoke sets, rim locks, wave-style brake rotors, and oil seals. Front and rear assemblies are sold separately.

*Fits '14-'17 YZ450F*  
**1SL-25302-00-00 (Silver)** ..... **\$535.99**  
**1SL-25302-10-00 (Black) (Shown)** ..... **\$551.99**



\*Shown here with both Front and Rear Wheels



A

**A. 19" REAR WHEEL ASSEMBLY\***

These complete original-equipment wheel assemblies are available for Yamaha YZ & WR models. Wheels are factory assembled, ready for installation, and come complete with hub assemblies, spoke sets, rim locks, wave-style brake rotors, and oil seals. Front and rear assemblies are sold separately

**NOTE:** 2014 YZ450F is compatible with rear wheel only.

*Fits '09-'13 YZ450F*  
**33D-W2539-00-00** (Silver) .....\$535.99

**B. GYTR® BILLET FRONT WHEEL SPACER KIT**

Get Yamaha Racing Team looks and function with these billet wheel spacers that have integrated dust covers and a seal lip that helps keep the spacers in place during wheel installation/removal.

*Fits '08-'13 YZ450F*  
**5XC-F51A0-V0-00** (Blue) (Front) .....\$40.99

**C. WHEEL SPACERS BY ZETA HIGH PERFORMANCE PRODUCTS**

Lightweight aluminum construction. Blue anodized. Enhanced styling. Installs in minutes.

*Fits '14-'17 YZ450F; '16-'17 YZ450FX*  
**DBY-ACC56-34-67** (Blue) (Front) (Shown) .....\$11.95

*Fits '09-'17 YZ450F*  
**DBY-ACC56-34-84** (Blue) (Rear) .....\$12.99

*Fits '15-'17 YZ450FX*  
**DBY-ACC56-34-68** (Blue) (Rear) .....\$12.99

**D. SUNLINE® RIM LOCK TOWER NUTS**

Machined from aircraft grade 6061-T6 aluminum. Closed nut design seals out mud and water, helping to prevent corrosion. Bevel washer design seats on the rim for a secure fit. Brilliant anodized finish.

*Fits all YZ models*  
**GYT-OSS55-60-23** (Blue) .....\$20.95



B



C



D

\*Shown here with both Front and Rear Wheels

**COVERS**

**GRAPHICS**

**HANDLEBARS & CONTROLS**

**PERFORMANCE**

**PROTECTION**

**SEATS**

**SPROCKETS & CHAINS**

**TRIM & ACCENTS**

**WHEELS**

**A. NEW! YZ MOTORCYCLE COVER**

Keep your YZ protected from dust at the track or in your garage with this Yamaha cover.

- Traditional Yamaha racing blue color featuring the GYTR, Yamalube and bLU cRU logos
- Lightweight material that can be quickly rolled up into the convenient attached storage bag
- Water resistant
- Equipped with a drawstring at the bottom to keep the cover in place

**NOTE:** Recommended for storage use only; not for trailering or transport

Fits all YZ models except YZ85

**1SL-F81A0-V0-00** (Blue) .....\$69.99



**A**

**B. NEW! GRAPHIC KIT BY D'COR VISUALS®**

This 16-piece graphic kit covers the plastics and the swingarm of the 2014-2017 YZ250F/YZ250FX.

- Thick, durable vinyl construction featuring the GYTR®, Yamalube® and bLU cRU® logos
- Proper colored number plate backgrounds – black for YZ250F white for YZ450F (Shown)
- Easy way to enhance the style of your YZ and refresh worn plastics
- Super strong adhesive holds up through tough riding conditions

Fits '14~'17 YZ250F

**DBY-ACC56-34-85** (Blue) .....\$129.99



**B**

**C. GYTR® PIVOTING LEVERS BY ARC™**

These levers are designed with a folding-pivot blade that will fold in the event of a tip-over. Pivot ratio mimics stock for excellent performance.

Fits '09~'17 YZ250F

**17D-H39B0-V0-00** (Black) (Clutch) (Shown).....\$75.99

Fits '15~'17 YZ250FX

**2GB-H39B0-V0-00** (Black) (Clutch).....\$72.99

Fits '01~'08 YZ250F

**GYT-5XC37-20-00** (Black) (Clutch).....\$75.99

Fits '05~'17 YZ250F; '15~'17 YZ250FX

**GYT-5XC37-30-00** (Black) (Brake) .....\$75.99



**C**

**D. SCOTT® MX2 GRIPS**

Designed for superior grip and comfort. Features underside waffle and soft-ridged upper patterns. Race proven. Grooved for safety wire. Sold in pairs.

Fits '01~'17 YZ250F; '15~'17 YZ250FX

**ABA-YZRMX-GP-BK** (Black) .....\$9.99



**E. GYTR® 10" CROSSBAR PAD**

Designed for handlebars with crossbar. Printed on scratch resistant, 15 mil. vinyl featuring the Yamaha logo.

Fits all Off-road Models with crossbar-equipped handlebars

**GYT-CROSS-BR-02** (Blue).....\$12.99

**F. GYTR® YAMAHA FACTORY RACING CLAMP COVER FOR 1-1/8" HANDLEBARS**

Printed on scratch-resistant 15-mil vinyl, featuring the Factory Racing logo. 10" long. For 1-1/8" Handlebars.

For all Off-road Motorcycles with 1-1/8" handlebars

**GYT-5XC25-18-BL** (Blue).....\$21.99



**D**



**E**



**F**

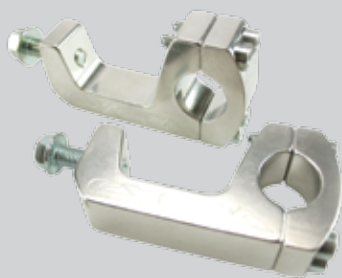

A

### A. CYCRA® SERIES ONE PROBEND® BAR "U" CLAMP SET

Cycra® blended the best features of a straight bar and the classic Probend®, to result in the Series One Probend®. Many riders prefer the straight bar end with more of a closed-in area but still want ample room for levers, hands, and controls. Cycra® was able to accommodate both by adding a subtle drop in the bar end.

"U" Clamp Set for ProTaper® Pre-2007/Renthal® Fatbar®/Tag T2 Handlebars. To be used with DBY-ACC56-34-01, DBY-ACC56-34-02 or DBY-ACC56-34-03.

Fits '05~'17 YZ250F; '15~'17 YZ250FX  
**DBY-ACC56-34-04 (Natural).....\$36.49**

"U" Clamp Set for 7/8" bars. To be used with DBY-ACC56-34-01, DBY-ACC56-54-02, or DBY-ACC56-34-03.  
**DBY-ACC56-34-05 (Natural).....\$44.95**

"U" Clamp Set for ProTaper® Evo and Contour/Neken. To be used with DBY-ACC56-34-01, DBY-ACC56-34-02 or DBY-ACC56-34-03.

Fits '05~'17 YZ250F; '15~'17 YZ250FX  
**DBY-ACC56-34-06 (Natural).....\$44.95**



B

### B. CYCRA® SERIES ONE PROBEND® HAND GUARDS

Cycra® blended the best features of a straight bar and the classic Probend®, to result in the Series One Probend®. Many riders prefer the straight bar end with more of a closed-in area but still want ample room for levers, hands, and controls. Cycra® was able to accommodate both by adding a subtle drop in the bar end. Requires "U" Clamp Set (sold separately) for specific type of handlebar.

Fits '05~'17 YZ250F; '15~'17 YZ250FX  
**DBY-ACC56-34-01 (Black).....\$64.95**  
**DBY-ACC56-34-02 (White).....\$64.95**  
**DBY-ACC56-34-03 (Blue).....\$65.49**



C

### C. CYCRA® FACTORY PROBEND CRM RACER PACK

Exclusive Yamaha color way and shield graphics. Factory Edition Probend® CRM Complete Racer Pack includes: center reach bars, center reach mounting clamps, classic Enduro™ shields, Powergrip alloy bar ends, and all necessary hardware. Revolutionary patented billet construction. Trademarked Probend® shape. Replaceable integrated plastic abrasion guard; center reach clamps provide maximum bite to secure hand guards and allows for superior clearance on a wide range of bars. Powergrip alloy bar ends fit standard and oversized bars. Sold in pairs.

Fits '05~'17 YZ250F; '15~'17 YZ250FX  
**DBY-ACC56-34-69 (White).....\$169.99**  
**DBY-ACC56-34-70 (Blue).....\$169.99**

### D. CYCRA® REBOUND HAND SHIELDS

Unrivaled strength against trail debris. Vigorously tested for durability and quality assurance. Great alternative to wraparound systems for woods or MX. Patented folding shield for those unexpected obstacles or accidental falls. Billet aluminum mounts and reinforced backbone on shield. In-molded rubber edge provides increased protection. Can be mounted over or under bars for easy installation and clean hand control area. Includes shields, mounts, and hardware. Sold in pairs.

Fits '05~'17 YZ250F; '15~'17 YZ250FX  
**DBY-ACC56-34-71 (Black).....\$79.99**  
**DBY-ACC56-34-72 (White).....\$79.99**  
**DBY-ACC56-34-73 (Blue).....\$79.99**



D

### E. CYCRA® CENTER REACH MOUNT COMPLETE RACER PACK

These Center Reach Mount (CRM) Complete Racer Packs include CRM Probend® bars, CRM mount clamps, classic Enduro™ shields, Powergrip bar ends, and Probend® abrasion guards. Revolutionary patent-pending design. Trademark Probend® shape. Replaceable integrated plastic abrasion guard. Center-reach clamps provide maximum bite to secure hand guards and allow for superior clearance on a wide range of bars. Powergrip alloy bar ends fit 1-1/8" oversized bars. Some control adjustments may be necessary.

Fits '05~'17 YZ250F; '15~'17 YZ250FX  
**GYT-OSS56-30-48 (White).....\$132.95**  
**GYT-OSS56-30-49 (Blue).....\$132.95**



E

COVERS

GRAPHICS

HANDLEBARS &amp; CONTROLS

PERFORMANCE

PROTECTION

SEATS

SPROCKETS &amp; CHAINS

TRIM &amp; ACCENTS

WHEELS

**COVERS**

**GRAPHICS**

**HANDLEBARS & CONTROLS**

**PERFORMANCE**

**PROTECTION**

**SEATS**

**SPROCKETS & CHAINS**

**TRIM & ACCENTS**

**WHEELS**

**A. GPR® STEERING STABILIZER**

GPR® Stabilizers are precision-machined for proven reliability and superior quality. Kit comes with the GPRV1 stabilizer and billet-machined mounting brackets. The patented "pin-less" mounting brackets eliminates any slop that might normally exist with the traditional aftermarket pin-and-slot mounting systems. Easy installation provides bolt-on performance. No drilling, tapping, or welding required. Intended to fit with OEM bars.

Fits '14~'17 YZ250F; '15~'17 YZ250FX  
**DBY-ACC56-34-63** .....\$495.00



**A**

**B. GYTR® PORTED CYLINDER HEAD ASSEMBLY**

The GYTR Ported Cylinder Head Assembly comes fully assembled and ready to install with no costly core changes or deposits or exchange programs that can add downtime. CNC milling helps eliminate the variances that hand porting can produce. The head was developed on the flow bench in conjunction with dyno and track testing to ensure the ultimate in performance and durability. GYTR Performance Camshaft Kit is included, as well as stock valve train and cam gears for durability and easy maintenance. GYTR Head Assemblies are used by Yamaha SX/ MX and ATV Race Teams. This accessory is restricted to closed-course use.

Fits '17 YZ250F  
**1SM-E11B0-S0-00** .....\$1,999.99

Fits '14~'16 YZ250F  
**1SM-E11B0-T0-00** .....\$2,040.99



**B**

**C. GYTR® HIGH COMPRESSION PISTON KIT**

The GYTR High Compression Piston Kit provides a performance boost throughout the rpm range while maintaining a high level of durability. Machined valve pockets provide additional valve clearance when used with higher lift camshafts. The kit includes piston rings, piston pin, and clips (uses stock replacements). Requires use of minimum 100-octane racing fuel. Boosts engine compression ratio to 14:1.

**IMPORTANT:** For use on 2014-2015 YZ250F models, you must replace stock oil nozzle with newer component (1SM-15155-10-00) for proper function of GYTR High Compression Piston.

Fits '14~'17 YZ250F; '15~'17 YZ250FX  
**1SM-E16A0-T0-00** .....\$265.99



**C**





A

**A. GYTR® OIL SPRAYER**

This oil sprayer is precision constructed out of CNC machined aluminum with a special 2-hole design.

Other features include:

- Manufactured to exact tolerances for performance and durability
- Provides additional under piston lubrication
- Required for use on '14-'15 YZ250F models with GYTR High Compression Piston Kit installed — you must replace the stock oil nozzle with this Oil Sprayer for proper function

Fits '14-'17 YZ250F  
**1SM-15155-10-00** .....\$17.92

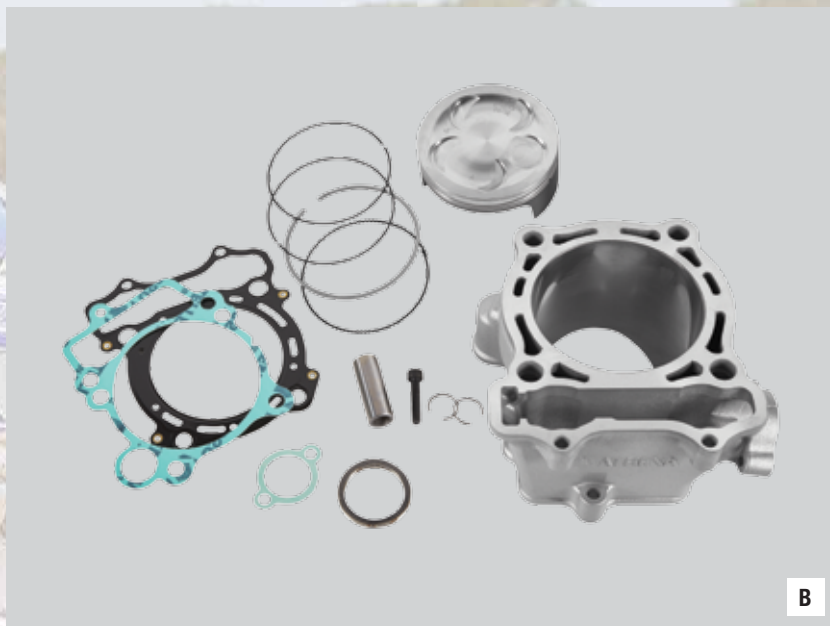

B

**B. ATHENA® 290CC BIG BORE KIT**

Big Bore Cylinder Kits include brand new nickel-carbide plated cylinder with enlarged water passages, precision made piston with rings, pins, clips, gaskets, O-rings, and all other parts needed for a complete installation. This accessory is restricted to closed-course use.

Fits '08-'09 YZ250F  
**GYT-OSS56-31-13** (Big Bore Kit) .....\$842.95  
**GYT-OSS56-31-14** (Replacement Piston Kit A) .....\$229.95  
**GYT-OSS56-31-15** (Replacement Piston Kit B) .....\$229.95

**C. GYTR® OFF-ROAD FLYWHEEL**

This complete flywheel assembly features an increase in inertia mass that smoothes the power delivery. Helps get power to the ground and keep your momentum up through corners and tricky sections, resulting in faster lap times and more race wins. Easy to install, allowing you the opportunity to change flywheels for different types of riding.

Fits '14-'17 YZ250F  
**1SM-H13A0-V0-00** (Shown) .....\$235.99  
 Fits '10-'13 YZ250F  
**17D-H13A0-V0-00** .....\$168.95

**D. GYTR® PERFORMANCE HIGH-FLOW AIR FILTER**

High-flow, two-layer foam filter offers optimized filtration while maximizing airflow. Increases performance. Filter is completely washable and reusable. Service with Genuine Yamaha Foam Filter Oil. This accessory is restricted to closed-course use.

Fits '14-'17 YZ250F; '15-'17 YZ250FX  
**1SL-E41C0-V0-00** .....\$27.99

**E. YAMAHA AIR BOX WASH CAP**

Eases air box cleaning and leaves no gaps that would allow water to penetrate when used. Features a large, tool-less knob and is made of ABS plastic with a fully sealed rubber gasket on the leading edge. It is easy to install and remove.

Fits '14-'17 YZ250F; '15-'17 YZ250FX  
**1SL-E41E0-V0-00** .....\$38.99



C



D



E

COVERS

GRAPHICS

HANDLEBARS & CONTROLS

PERFORMANCE

PROTECTION

SEATS

SPROCKETS & CHAINS

TRIM & ACCENTS

WHEELS

**COVERS**

**GRAPHICS**

**HANDLEBARS & CONTROLS**

**PERFORMANCE**

**PROTECTION**

**SEATS**

**SPROCKETS & CHAINS**

**TRIM & ACCENTS**

**WHEELS**

**A. YAMAHA GENUINE GASKET KIT**

These original-equipment Top End and Bottom End Gasket Kits were designed for convenience and total savings. Kits include the necessary gaskets, seals, and O-rings needed to reassemble your engine. They also include a complete part number list of all gaskets, seals, and O-rings for an in-depth engine overhaul.

*Fits '14~'17 YZ250F; '15~'17 YZ250FX*  
**1SM-W0001-00-00 (Top End).....\$73.32**

*Fits '14~'16 YZ250F; '15~'17 YZ250FX*  
**1SM-W0002-00-00 (Bottom End) (Shown).....\$40.56**

*Fits '17 YZ250F*  
**1SM-W0002-10-00 (Bottom End) .....\$65.35**

*Fits '01~'13 YZ250F*  
**5NL-W0001-00-00 (Top End).....\$73.99**  
**5NL-W0002-00-00 (Bottom End) .....\$89.99**



**A**



**B**

**B. GYTR® TWO-STAGE FOAM AIR FILTER**

High-flow, two-layer foam filter offers optimized filtration while maximizing airflow. Increases performance. Filter is completely washable and reusable. Service with Yamaha Genuine Foam Filter Oil. This accessory is restricted to closed-course use.

*Fits '05~'13 YZ250F*  
**GYT-4EW95-00-00 .....\$32.49**



**C**

**C. PRE-FILTER BY OUTERWEARS®**

Offers less maintenance in dusty conditions and pre-filters dirt. No critical airflow restriction or power loss. Works with Yamaha OEM Air Filter or GYTR Air Filter.

*Fits '02~'13 YZ250F*  
**GYT-OSS56-31-85 (Blue) .....\$22.49**



**D**

**D. GYTR® AIR BOOT**

Developed on the flow bench in conjunction with dyno and track testing. Higher volume airbox with longer intake. Increases air volume for optimized performance. Uses stock air filter components. Intended for use with GYTR Ported Cylinder Head for the YZ250F (1SM-E11B0-T0-00), sold separately. Simple installation and easy maintenance.

*Fits '14~'17 YZ250F*  
**1SM-E41H0-V0-00 .....\$133.99**

**E. GYTR® BY FMF® MEGABOMB® HEAD PIPE**

The full titanium construction MegaBomb® header can provide as much as a 3 hp boost, plus the MegaBomb® actually reduces noises levels by as much as 1.5 dBA. Used by Yamaha Race Teams. The MegaBomb® is designed to perform at the world's highest levels of racing. The MegaBomb® produces long header torque and short header over-rev. Made from premium titanium material. This accessory is restricted to closed-course use.

*Fits '14~'17 YZ250F; '15~'17 YZ250FX*  
**1SM-E46A0-T0-00 (Stainless Steel) .....\$357.99**

*Fits '14~'17 YZ250F; '15~'17 YZ250FX*  
**1SM-E46A0-V0-00 (Titanium) (Shown) .....\$463.99**

*Fits '10~'13 YZ250F*  
**17D-E46A0-T0-00 (Titanium) .....\$349.99**



**E**

**F. GYTR® BY FMF® POWERBOMB® HEAD PIPE**

The Stainless Steel PowerBomb® is a four-stroke header that incorporates the patented PowerBomb® module at a precise location in the initial stage of the header. By positioning this "Bomb" at a key point in the system, increased performance and flow is achieved through the expansion and contraction of exhaust sonics through the system. The result is a flow increase of nearly 10%! The outer chamber in the PowerBomb® allows the air to expand, cool, and ramp back up at a higher velocity. Additionally, the PowerBomb® is a "pre-muffler" of sorts, which helps to lower the bike's sound output by providing more sound absorbing surface area for the sound medium (exhaust gases). The PowerBomb® provides power focused in the mid to upper rpm range. This accessory is restricted to closed-course use.

*Fits '10~'13 YZ250F*  
**17D-E46A0-S0-00 (Stainless Steel) .....\$199.99**



**F**



A



B



C



D



E



F

**A. GYTR® BY FMF® TITANIUM RCT FACTORY 4.1™ MUFFLER**

The patented FMF® Resonance Chamber Technology enhances and refines exhaust pressure. Its patented core shape lowers sound level while maintaining maximum power output, and the patented canister shape increases internal volume for more sound-absorbing material. Factory Forward Engineering centralizes mass and is less prone to impact damage. Maintenance is easy remove four screws on the front end cap, and the innovative rear end cap simplifies the installation of the spark arrester (sold separately) or tuning tip inserts. Includes QuietCore™ 94 dBA insert. Meets AMA® and FIM sound requirements. It is compatible with stock or FMF® header and made in the U.S.A. This accessory is restricted to closed-course use. Head Pipe not included.

Fits '14-'17 YZ250F; '15-'17 YZ250FX  
**1SM-E47A0-V0-00 (Titanium) .....\$599.99**

**B. GYTR® BY FMF® FACTORY 4.1™ MUFFLER**

This Factory 4.1™ Muffler incorporates the latest FMF® Resonance Chamber Technology. The patented chamber design enhances and refines exhaust pressure. Its patented core shape lowers sound level while maintaining maximum power output, and the patented canister shape increases internal volume for more sound-absorbing material. Factory Forward Engineering centralizes mass and is less prone to impact damage. Maintenance is made easy with the removal of four screws on the front end cap, and the innovative rear end cap simplifies installation of the spark arrester (sold separately) or tuning tip inserts. Includes QuietCore™ 94 dBA insert. Meets AMA® and FIM sound requirements. Compatible with stock or FMF® header. Built 100% in the U.S.A. This accessory is restricted to closed-course use.

Fits '06-'13 YZ250F  
**2S2-E47A0-T0-00 (Aluminum) .....\$499.99**

**C. POWERCORE® 4 HEX MUFFLER**

The PowerCore® 4 is designed to increase the horsepower and torque throughout the entire power curve and give you a noticeable power increase that is very usable and beneficial, no matter your riding style or ability. Features include space age internal packing for maximum packing life and a high-flow modular end cap. Internal core shape uses high-flow technology. Enhanced sonic evacuation provides for higher flow and increased power. Muffler includes removable spark arrester. 97.5 dBA sound level. 95.5 dBA with QuietCore™ Spark Arrestor Insert, sold separately. This accessory is restricted to closed-course use. Head Pipe not included.

Fits '14-'17 YZ250F; '15-'17 YZ250FX  
**1SM-E47A0-T0-00 (Aluminum) .....\$336.99**

**D. GYTR® BY FMF® QUIETCORE™ SPARK ARRESTOR INSERT**

Noise-reducing insert with spark arrester for the GYTR® by FMF® Factory 4.1™ Mufflers. Muffler is for closed-course use regardless of modification.

Fits '09-'17 YZ250F  
**33D-E46C0-R0-00 .....\$39.99**

**E. GYTR® BY FMF® QUIETCORE™ SPARK ARRESTOR INSERT**

Noise-reducing insert with spark arrester for the GYTR® by FMF® PowerCore® 4 Mufflers. Sound level is 95 dBA on 250 models. Muffler is for closed-course use regardless of modification.

Fits '09-'17 YZ250F; '15-'17 YZ250FX  
**33D-E46C0-T0-00 .....\$39.99**

**F. GYTR® BY FMF® REPLACEMENT SPARK ARRESTOR INSERT**

The GYTR® by FMF® Replacement Spark Arrestor Insert is designed to fit the GYTR by FMF® PowerCore® 4 Mufflers.

Fits '09-'17 YZ250F  
**33D-E46C0-V0-00 .....\$30.99**

COVERS

GRAPHICS

HANDLEBARS & CONTROLS

PERFORMANCE

PROTECTION

SEATS

SPROCKETS & CHAINS

TRIM & ACCENTS

WHEELS

- COVERS
- GRAPHICS
- HANDLEBARS & CONTROLS
- PERFORMANCE
- PROTECTION
- SEATS
- SPROCKETS & CHAINS
- TRIM & ACCENTS
- WHEELS

**A. GYTR® BILLET CLUTCH BASKET**

Precision-machined from the highest grade of aluminum and then anodized to achieve an exceptionally hard, wear-resistant surface. This clutch basket provides amazing, race-proven durability.

Fits '14~'17 YZ250F; '15~'17 YZ250FX  
**1SM-E63A0-V0-00** .....\$224.99

Fits '10~'13 YZ250F  
**17D-E63A0-V0-00** (Shown) .....\$291.95

Fits '01~'08 YZ250F  
**GYT-5XC56-10-00** .....\$239.95

**B. GYTR® INNER CLUTCH HUB**

The GYTR Billet Clutch Inner Hub is precision machined from the highest grade of aluminum, then hard anodized to achieve an exceptionally hard wear-resistant surface. Additional oil passages help improve clutch performance and contribute to a 20% weight reduction and less rotational mass for improved acceleration.

Fits '01~'17 YZ250F; '15~'17 YZ250FX  
**1SM-E63C0-V0-00** .....\$286.99

**C. GYTR® BILLET CLUTCH PRESSURE PLATE**

Precision-machined from the highest grade of aluminum, then hard anodized to achieve an exceptionally hard, wear-resistant surface for amazing race-proven durability. Additional oil passages help improve clutch performance and also contribute to a 30% weight reduction and less rotational mass for improved acceleration.

Fits '14~'17 YZ250F; '15~'17 YZ250FX  
**1SM-E63B0-V0-00** (Shown) .....\$164.99

Fits '01~'13 YZ250F  
**GYT-5XC56-20-00** .....\$166.95

**D. GYTR® BILLET CLUTCH COVER**

Precision-machined from the highest grade of aluminum and then anodized to achieve an exceptionally hard, wear-resistant surface.

Fits '14~'17 YZ250F; '15~'17 YZ250FX  
**1SM-E54E0-V0-00** (Shown) .....\$145.99

Fits '01~'13 YZ250F  
**17D-E54E0-V0-00** .....\$143.95

**E. YAMAHA GENUINE OFF-ROAD CLUTCH KITS**

These complete Yamaha Clutch Kits include the plates, springs, and gaskets, ready to install. Refer to service manual for installation instructions.

Fits '17 YZ250F  
**1SM-W001G-10-00** .....\$139.99

Fits '14~'16 YZ250F  
**1SM-W001G-00-00** .....\$139.48

Fits '15~'17 YZ250FX  
**2GB-W001G-20-00** .....\$164.99

Fits '09~'13 YZ250F  
**5XC-W001G-20-00** .....\$167.99

Fits '08 YZ250F  
**5XC-W001G-10-00** .....\$167.99

Fits '06~'07 YZ250F  
**5XC-W001G-00-00** .....\$167.99

**F. GYTR® KICK START REMOVAL KIT**

Allows customer to remove the kick start lever, shaft, and gear. Kick Start lever can always be re-installed on the bike at a later date, if desired.

Fits '15~'17 YZ250FX  
**B29-E57A0-V0-00** .....\$30.99



**A**



**B**



**C**



**D**



**E**

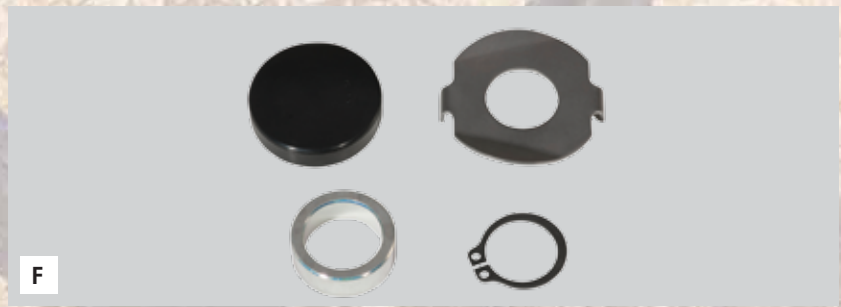

**F**



A

**A. GYTR® POWER TUNER**

This easy plug-in fuel-injection and ignition tuning tool allows riders to quickly adjust the fuel and ignition maps to suit riding conditions and rider preference. Allows nine easy-to-program adjustment points for both the fuel and ignition maps. Monitor function allows user to monitor the data from various sensors on the bike as well as adjust idle timing, see engine running time, and self-diagnosis function. Powered by two AA batteries, thus no laptop or time consuming downloads necessary. Unit does not have to be plugged into bike to create maps. Compact design can fit in the palm of your hand, pocket, etc. Memory function can save up to nine custom maps. Plugs right into the YZ250F and YZ250FX ECU.

*Fits '14-'17 YZ250F; '15-'17 YZ250FX*  
**33D-H59C0-V1-00** .....\$298.99

**B. RADIATOR FAN KIT**

This radiator fan kit adds a cooling fan to the right side radiator, increasing the overall cooling capability. Good for tight, muddy riding conditions and competition. Easy installation—motorcycle is already pre-wired for plug-and-play. No modifications necessary. YZ models are for closed-course use regardless of modification.

*Fits '15-'17 YZ250FX*  
**B29-E24E0-V0-00** .....\$72.99

**C. OVERSIZED FUEL TANKS BY IMS**

These tanks are designed to carry more fuel and enhance the appearance of your motorcycle. Larger capacity than stock, yet very slim and sleek. Provides greater riding distance per full tank. Perfect for races where the extra distance can mean the difference between winning and losing. These tanks are made with Polyethylene Crosslink for extra strength and durability. Suitable only for closed-course competition.

*Fits '14-'17 YZ250F*  
**DBY-ACC56-34-62** (Natural) (2.9 Gal.) (Shown).....\$274.49

*Fits '17 YZ250FX*  
**DBY-ACC56-34-81** (Black) (3.0 Gal.).....\$274.99

*Fits '15-'16 YZ250FX*  
**DBY-ACC56-34-82** (Black) (3.0 Gal.) (Shown) .....\$274.99  
**DBY-ACC56-34-83** (Natural) (3.0 Gal.) .....\$274.99



B

**D. HAMMERHEAD™ ROCKET LAUNCHER HOLESHOT DEVICE - BLACK**

The #1 problem with most holeshot devices is failure due to the push pin getting kinked and locked in the sides of the soft aluminum catch slot built into the fork strap. This is a result of the pressure pulling the pieces apart and the hard steel pin crushing and deforming the soft aluminum button body and fork strap. With these old designs, it is not a matter of if, but when, you will have a failure that could cost you a race and possibly much more. With the new-design Hammerhead™ Rocket Launcher, your holeshot is guaranteed.

*Fits '06-'17 YZ250F*  
**DBY-ACC56-33-08** (Black).....\$102.95  
**DBY-ACC56-33-09** (Blue) .....\$102.95



C



D

- COVERS
- GRAPHICS
- HANDLEBARS & CONTROLS
- PERFORMANCE
- PROTECTION
- SEATS
- SPROCKETS & CHAINS
- TRIM & ACCENTS
- WHEELS

**COVERS**

**GRAPHICS**

**HANDLEBARS & CONTROLS**

**PERFORMANCE**

**PROTECTION**

**SEATS**

**SPROCKETS & CHAINS**

**TRIM & ACCENTS**

**WHEELS**

**A. YAMAHA GENUINE FRONT FORK SEAL KITS**

These Yamaha Genuine Fork Seal Kits come with the original equipment fork and dust seats. Don't settle for the next best thing from the aftermarket; use Yamaha Genuine Fork Seal Kits for longer life and less maintenance. Don't forget to order the proper fork oil for your bike, as well. Yamaha Fork Oils are formulated specifically for your model and deliver the highest suspension performance possible.

*Fits '10~'17 YZ250F; '15~'16 YZ250FX*

**17D-W003B-00-00 (Shown) .....\$67.99**

*Fits '99~'03 YZ250F*

**5ET-W003B-00-00 .....\$62.99**

*Fits '04~'09 YZ250F*

**1C3-W003B-00-00 .....\$67.99**

**B. FORK BLEEDERS BY MOTION PRO®**

The Fork Bleeders by Motion Pro® features:

- Releases trapped air in forks with push of a button
- Small unobtrusive profile
- Installs in minutes
- Fits any bike with a 5mm x 0.08 thread pitch

*Fits '06~'17 YZ250F; '15~'17 YZ250FX*

**DBY-ACC56-34-66 .....\$15.99**

**C. YAMAHA GENUINE BEARING KITS**

These Yamaha Genuine Bearing Kits come with all of the components needed to rebuild the swingarm pivot, shock linkage, and shock bearings. Kits include all of the original equipment bearings, seals, O-rings, and collars your bike came with. Unlike some of the aftermarket companies that use a lower quality bearing, these bearings are O-ring-sealed to prevent intrusion of dirt, mud, and water and are made of top quality materials. If you don't want to do the job again and in half the time your original bearings lasted, then use these Yamaha Genuine kits.

*Fits '07~'17 YZ250F; '15~'17 YZ250FX*

**1SS-W002G-00-00 (Shock) .....\$77.99**

*Fits '06 YZ250F*

**1C3-W002G-00-00 (Shock) .....\$62.99**

*Fits '09~'17 YZ250F; '15~'17 YZ250FX*

**33D-W002E-00-00 (Shock Linkage) (Shown).....\$89.99**

*Fits '10~'13 YZ250F*

**17D-W002E-00-00 (Shock Linkage) .....\$89.99**

*Fits '08 YZ250F*

**1HC-W002E-00-00 (Shock Linkage) .....\$89.99**

*Fits '07 YZ250F*

**1P8-W002E-00-00 (Shock Linkage).....\$89.99**

*Fits '14~'17 YZ250F; '15~'17 YZ250FX*

**33D-W002C-00-00 (Swingarm Pivot).....\$81.99**

*Fits '06~'13 YZ250F*

**1HC-W002C-00-00 (Swingarm Pivot).....\$81.99**

**D. GYTR® BY BRAKING™ SOLID REAR BRAKE ROTOR**

The GYTR by BRAKING™ Solid Rear Brake Rotor is a high quality, durable, slot-less brake rotor that helps extend brake pad life in muddy conditions.

*Fits '06~'16 YZ250F; '15~'16 YZ250FX*

**1SL-F58G0-V0-00 .....\$107.99**



**A**



**B**



**C**



**D**

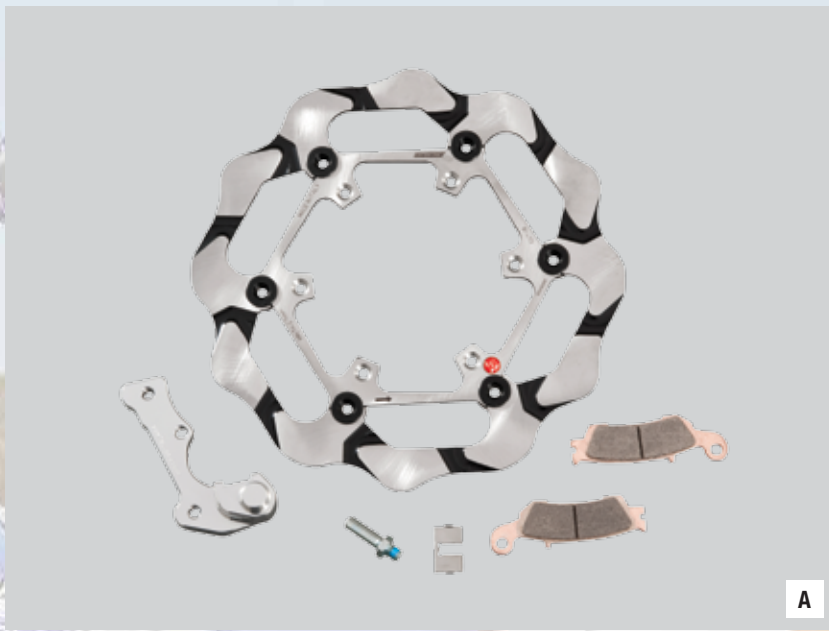

A

**A. BATFLY 270 OVERSIZED ROTOR KIT**

The 270mm Batfly is the natural evolution of the popular BRAKING™ design profile and is easily recognizable thanks to the black grooves that are cut across the outer braking track resembling bat wings, hence the name “Batfly.” The new version features a new carrier that has been 100% heat treated and redesigned for strength as well as a redesign of the outer profile and grooves for a trick new look. With the larger 270mm diameter, maximum braking power is obtained, but with the Batfly design, brake feeling is increased even further, achieving the perfect combination of stopping power and brake feel. BRAKING®’s Batfly profile maintains the lowest temperature possible in race conditions, resulting in a better progression in brake feeling than any other oversized rotor kit available. Kit includes 270mm oversized Batfly design rotor, caliper relocation bracket, and a set of CM46 Sintered Race series pads.

Fits '07~'13 YZ250F  
**GYT-OSS56-30-63** ..... \$354.95

**B. GYTR® STAINLESS STEEL BRAIDED BRAKE LINE KIT**

These top-quality brake lines are designed to not fatigue even under extreme conditions.

Fits '09~'17 YZ250F; '15~'17 YZ250FX  
**5XC-F58A0-V0-00 (Rear)**..... \$61.99

Fits '10~'17 YZ250F  
**17D-F58E0-V0-00 (Front) (Shown)**..... \$66.99

Fits '08~'09 YZ250F  
**5XC-F58E0-V0-00 (Front)** ..... \$73.99



B

**C. GYTR® BILLET IGNITION COVER**

Constructed of billet aluminum and coated with a hard anodized finish, the GYTR Billet Ignition Cover was developed in conjunction with race teams to provide a stronger cover that limited the risk of loosening oil cap and large timing plug during a race. The improved finish is both durable and attractive. Installation removes the oil cap and large timing plug. Note: Image of YZ450F ignition cover shown.

Fits '14~'17 YZ250F  
**1SM-E54G0-V0-00** ..... \$250.99



C

**D. GYTR® RADIATOR BRACES**

Constructed of lightweight aluminum for an optimized strength-to-weight ratio. Thinner and lighter material is possible due to the rolled edges that provide extra strength. Structural ribs run along the sides of the braces to limit radiator damage from side impact. All required mounting hardware included. No trimming of the plastics is required to install.

Fits '14~'17 YZ250F  
**1SL-E24C0-V0-00** ..... \$103.95

Fits '10~'13 YZ250F  
**17D-E24C0-V0-00** ..... \$107.95



D

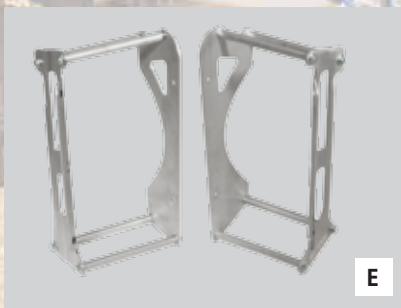

E

**E. GYTR® RADIATOR CAGES**

These GYTR radiator cages offer another level of protection against serious radiator damage. Full cage with rod design. Lightweight yet sturdy constructed with stamped 3.2mm aluminum to provide strength and protection in the event of side impacts. No modifications necessary. Easy-to-install design means radiator removal is not required. Installs in minutes.

Fits '14~'17 YZ250F  
**1SL-E24C0-S0-00** ..... \$109.95

Fits '15~'17 YZ250FX  
**2GB-E24C0-V0-00 (Shown)**..... \$133.99



F

**F. ENDURO™ SKID PLATE**

This aluminum plate is designed with side skirts to help protect the lower frame rails, critical engine components, water pump, ignition cover, and clutch components even on the gnarliest enduro course.

Fits '14~'17 YZ250F  
**1SL-F14B0-V0-00 (Aluminum) (Shown)**..... \$140.95

Fits '10~'13 YZ250F  
**17D-F14B0-T0-00** ..... \$132.95

- COVERS
- GRAPHICS
- HANDLEBARS & CONTROLS
- PERFORMANCE
- PROTECTION
- SEATS
- SPROCKETS & CHAINS
- TRIM & ACCENTS
- WHEELS

- COVERS
- GRAPHICS
- HANDLEBARS & CONTROLS
- PERFORMANCE
- PROTECTION
- SEATS
- SPROCKETS & CHAINS
- TRIM & ACCENTS
- WHEELS

**A. GYTR® ALUMINUM SKID PLATE**

This GYTR skid plate helps glide your bike over obstacles and provides additional protection for the water pump and engine covers. Lightweight and sturdy aluminum construction. Installs to existing mounting tabs.

Fits '15~'17 YZ250FX  
**2GB-F14B0-V0-00** .....\$128.99



**B. GYTR® PLASTIC CHAIN GUIDE**

This ultra-durable UHMWPE plastic guide is designed to flex, not bend, in the event of impact.

Fits '07~'17 YZ250F; '15~'17 YZ250FX  
**17D-F21E0-V0-00 (Black)**.....\$88.99



**C. GYTR® MX GLIDE PLATE**

The GYTR MX Glide Plate is constructed of 4mm composite. The MX Glide Plate is a flexible, lightweight and low drag coefficient alternative to aluminum glide plates when needing a smooth surface for "gliding" over obstacles. It can be used in conjunction with stock water pump cover or GYTR Water Pump Guard.

Fits '14~'17 YZ250F  
**1SL-F14B0-S0-00** .....\$128.99

**D. WATER PUMP GUARD**

This lightweight 4mm composite guard replaces the stock plastic guard for added protection to the right side engine components and lower drag coefficient. It will flex and not bend during an impact and can be used alone or with GYTR MX Glide Plate.

Fits '14~'17 YZ250F  
**1SL-F14C0-V0-00** .....\$51.99

**E. CARBON FIBER REAR CALIPER GUARD BY LIGHTSPEED®**

Durable, lightweight carbon fiber design helps protect your rear brake caliper.

Fits '06~'17 YZ250F; '15~'17 YZ250FX  
**GYT-OSS56-30-27** .....\$46.95



**F. CARBON FIBER FRONT DISC GUARD BY LIGHTSPEED®**

Carbon fiber construction provides the ultimate combination of a lightweight yet super strong part. Directional venting aids heat reduction, reducing brake fade. Kevlar® reinforcement patch placed in strategic areas to aid in durability. Helps protect the front brake disc. Will work on oversized brake rotors up to 295mm.

Fits '06~'13 YZ250F  
**GYT-OSS56-30-29** .....\$108.49



**G. CARBON FIBER RIGHT-HAND FORK LUG COVER BY LIGHTSPEED®**

This lightweight, functional cover protects the fork lug and rebound clicker while acting as a small glide plate to prevent "hang ups" in ruts.

Fits '07~'13 YZ250F  
**GYT-OSS56-32-54** .....\$72.95



**H. CARBON FIBER REAR CALIPER GUARD & DISC GUARD SET BY LIGHTSPEED®**

This kit includes carbon fiber components that will help protect the rear brake disc and caliper. Sold as a set.

Fits '06~'17 YZ250F; '15~'17 YZ250FX  
**GYT-OSS56-30-28** .....\$97.95







A



B



C



D



E

**A. GYTR® PLASTIC REAR BRAKE GUARD**

The GYTR Rear Brake Disc Guard is made of ultra-durable UHMWPE (Ultra High Molecular Weight Polyethylene). This disc guard is designed to flex and not bend upon impact. Improved durability in gnarly off-road conditions. Machined collars and OE style hardware allows for easy, same tool installation.

Fits '06-'17 YZ250F; '15-'17 YZ250FX  
**1DX-F58FO-VO-00**.....\$112.99

**B. YAMAHA GENUINE REPLACEMENT SIDE COVERS**

The Yamaha Genuine Replacement Side Covers are sold as a pair. Yamaha Genuine replacements for the stock covers (graphics not included). Less expensive than purchasing stock covers that use a very expensive inlay process for the graphics. Includes metal collars.

Fits '14-'17 YZ250F; '15-'17 YZ250FX  
**1SL-W003D-00-00 (White)**.....\$99.99

**C. POWERFLOW INTAKE SHROUDS BY CYCRA®**

Patented Cycra® Powerflow technology dramatically reduces radiator, fuel tank, and engine head temperatures. Integration of forced air inlets into the airbox cover allows additional air intake and eliminates the need to drill holes. Scoops allow more air into the airbox for added performance. Airbox cover mates to the Powerflow shrouds for complete system. Narrows the space between the rider's leg and knee area for better ergonomics. Leading edge is "tucked in" to prevent boot snag.

Fits '14-'17 YZ250F; '15-'17 YZ250FX  
**DBY-ACC56-34-74 (Black)**.....\$124.99  
**DBY-ACC56-34-75 (White)**.....\$124.99  
**DBY-ACC56-34-76 (Blue)**.....\$124.99

**D. CYCRA® PLASTIC BODY KITS**

Powerflow Intake Race Systems dramatically decreases operating temperatures with by-pass airflow technology that maximizes cooling efficiency. Injection-molded precise fit and high gloss finish. Kit includes: Powerflow Intake Radiator Shrouds, Performance Front Fender, Powerflow Rear Fender, Stadium Number Plate, Side Number Panels, Airbox Cover, and Fork Guards.

Fits '14-'17 YZ250F  
**DBY-ACC56-34-77 (Blue/White)**.....\$257.99  
**DBY-ACC56-34-78 (Black)**.....\$257.99  
**DBY-ACC56-34-79 (White)**.....\$257.99  
**DBY-ACC56-34-80 (Blue)**.....\$257.99

**E. CYCRA® POWERFLOW INTAKE SHROUDS**

Patented Cycra® Powerflow technology dramatically reduces radiator, fuel tank, and engine head temperatures. Integration of forced air inlets into the airbox cover allows additional air intake and eliminates the need to drill holes. Scoops allow more air into the airbox for added performance. Airbox cover mates to the Powerflow shrouds for complete system. Narrows the space between the rider's leg and knee area for better ergonomics. Leading edge is "tucked in" to prevent boot snag.

Fits '14-'17 YZ250F; '15-'17 YZ250FX  
**DBY-ACC56-34-74 (Black)**.....\$124.99  
**DBY-ACC56-34-75 (White)**.....\$124.99  
**DBY-ACC56-34-76 (Blue) (Shown)**.....\$124.99

COVERS

GRAPHICS

HANDLEBARS & CONTROLS

PERFORMANCE

PROTECTION

SEATS

SPROCKETS & CHAINS

TRIM & ACCENTS

WHEELS

**COVERS**

**GRAPHICS**

**HANDLEBARS & CONTROLS**

**PERFORMANCE**

**PROTECTION**

**SEATS**

**SPROCKETS & CHAINS**

**TRIM & ACCENTS**

**WHEELS**

**A. YAMAHA SHORT SEAT**

Shorter than the stock seat (slightly under 1" shorter). Fully assembled seat assembly with gripper seat cover. Great for shorter riders. Helps hold rider in seated position. Simple installation and removal

*Fits '14-'17 YZ250F; '15-'17 YZ250FX*

**B11-F47C0-T0-00** .....\$133.99

**B. YAMAHA TALL SEAT**

Taller than the stock seat (slightly under 1" taller). Fully assembled seat assembly with gripper seat cover. Great for taller riders. Helps hold rider in seated position. Simple installation and removal.

*Fits '14-'17 YZ250F; '15-'17 YZ250FX*

**B11-F47C0-V0-00** .....\$133.99

**C. GYTR® REAR SPROCKETS**

These GYTR Rear Sprockets are made from 7075-T6 billet aluminum CNC-machined for maximum fit accuracy. Features a radial mud groove etched just inside the sprocket teeth to shed mud and grit which saves weight and increases chain life. Sprocket sizes other than stock are for closed-course competition only on '06 and later off-road models and all street legal models. Changing the final drive ratio affects exhaust emissions and also affects speedometer readings.

*Fits '01-'17 YZ250F; '15-'17 YZ250FX*

<b>GYT-75339-47-BK</b> (Black, 47T) .....	\$61.95
<b>GYT-75339-47-BL</b> (Blue, 47T) .....	\$62.49
<b>GYT-75339-48-BK</b> (Black, 48T) .....	\$62.49
<b>GYT-75339-48-BL</b> (Blue, 48T) .....	\$62.49
<b>GYT-75339-48-MG</b> (Gold, 48T) .....	\$61.95
<b>GYT-75339-49-BK</b> (Black, 49T) .....	\$62.49
<b>GYT-75339-49-BL</b> (Blue, 49T) .....	\$62.49
<b>GYT-75339-49-MG</b> (Gold, 49T) .....	\$62.49
<b>GYT-75339-50-BK</b> (Black, 50T) .....	\$62.49
<b>GYT-75339-50-BL</b> (Blue, 50T) .....	\$62.49
<b>GYT-75339-50-MG</b> (Gold, 50T) .....	\$62.49
<b>GYT-75339-51-BK</b> (Black, 51T) .....	\$62.49
<b>GYT-75339-51-BL</b> (Blue, 51T) .....	\$62.49
<b>GYT-75339-51-MG</b> (Gold, 51T) .....	\$61.95
<b>GYT-75339-52-BK</b> (Black, 52T) .....	\$61.95
<b>GYT-75339-52-BL</b> (Blue, 52T) .....	\$62.49
<b>GYT-75339-52-MG</b> (Gold, 52T) .....	\$61.95
<b>GYT-75339-53-BK</b> (Black, 53T) .....	\$61.95
<b>GYT-75339-53-BL</b> (Blue, 53T) .....	\$61.95

**D. GYTR® FRONT SPROCKETS BY TALON®**

Made from heat-treated chromoly steel and CNC-machined to extremely high tolerances. Zinc finish to help combat corrosion. Sprockets feature self-cleaning grooves to shed mud and grit, as well as reduce weight while maintaining strength. Sprocket sizes that increase the final drive ratio over stock are for closed-course competition only on '06 and later models because regulated exhaust emissions are affected.

*Fits '14-'17 YZ250F; '15-'17 YZ250FX*

<b>GYT-75504-13-00</b> (Silver, 13T) .....	\$26.49
<b>GYT-75504-14-00</b> (Silver, 14T) .....	\$26.49

*Fits '05-'13 YZ250F*

<b>GYT-75503-12-00</b> (Silver, 12T) .....	\$26.49
<b>GYT-75503-13-00</b> (Silver, 13T) .....	\$26.49
<b>GYT-75503-14-00</b> (Silver, 14T) .....	\$26.49

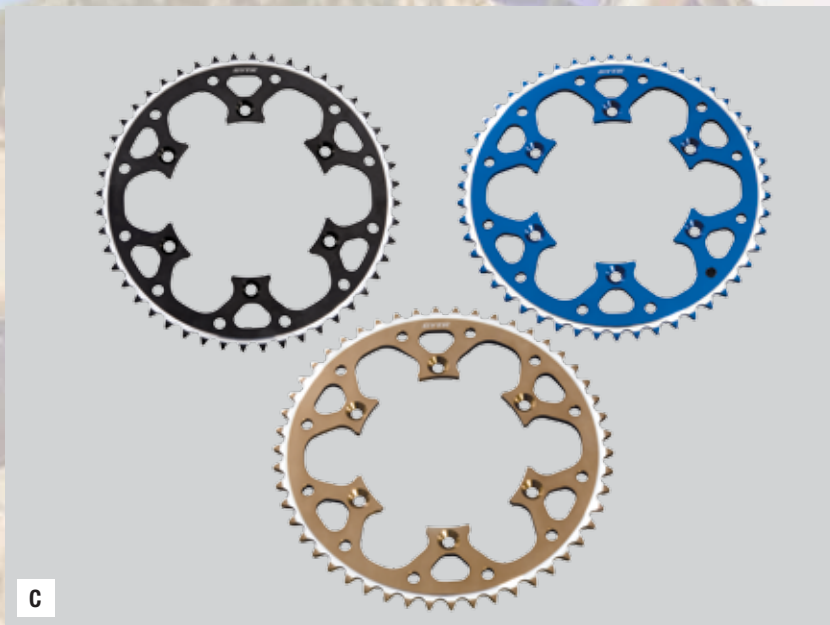



A



**A. GYTR® ULTRA-HIGH PERFORMANCE RACING CHAINS BY EK®**

GYTR Ultra-High Performance Racing Chains & Links by EK® offer the ultimate balance of performance and durability for various applications. Chains will not work on vehicles with a shaft drive.

**520 GDXL(2) Quadra-Ring Lite Chain:**

- Displacement Limit: Up to 650cc
- Tensile strength = 8,500 lb
- 120 links
- Designed to reduce friction up to 40%
- Lasts 50% longer than the conventional O-ring chains
- Lighter version of the 520 GDXL for small and mid-sized off-road motorcycles, sportbikes, and ATVs

GYT-ACC56-20-01 (Gold, 520 GDXL2 X-Ring Lite Chain).....	<b>\$102.95</b>
GYT-ACC56-20-20 (Gold, 520 GDXL2 Clip Type Master Link) ..	<b>\$4.95</b>
GYT-ACC56-20-02 (Gold, 520 GDXL2 Rivet Type Master Link) ..	<b>\$4.99</b>
GYT-ACC56-20-03 (Natural, 520 GDXL2 X-Ring Lite Chain).....	<b>\$109.49</b>
GYT-ACC56-20-04 (Natural, 520 GDXL2 Rivet Type Master Link) ..	<b>\$4.99</b>
GYT-ACC56-20-21 (Natural, 520 GDXL2 Clip Type Master Link).....	<b>\$4.99</b>

**520 GDO(2) O-Ring Chain:**

- Displacement Limit: Up to 650cc
- Tensile strength = 8,000 lb
- 120 links
- Manufactured by the inventor of the world's first O-ring
- Ideal for small and mid-sized off-road motorcycles, sportbikes, and ATVs
- Includes clip and rivet type master link

GYT-ACC56-20-05 (Gold, 520 GDO2 O-Ring Chain).....	<b>\$84.99</b>
GYT-ACC56-20-22 (Gold, 520 GDO2 Clip Type Master Link) ..	<b>\$5.99</b>
GYT-ACC56-20-06 (Gold, 520 GDO2 Rivet Type Master Link) ..	<b>\$3.49</b>
GYT-ACC56-20-07 (Natural, 520 GDO2 O-Ring Chain) ..	<b>\$74.99</b>
GYT-ACC56-20-23 (Natural, 520 GDO2 Clip Type Master Link) ..	<b>\$5.99</b>
GYT-ACC56-20-08 (Natural, 520 GDO2 Rivet Type Master Link) ..	<b>\$3.49</b>

**520 GMX2 Non-Sealed (Non O-Ring) Chain:**

- Displacement Limit: Up to 500cc
- Tensile strength = 8,400 lb
- 120 links
- Specifically designed for Motocross and Supercross
- Race-tested by Factory Riders to meet today's high performance machines
- High-tech CrH-coated pins for extremely hard outside surface and softer inside to increase the impact strength
- Includes clip and rivet type master link

GYT-ACC56-20-09 (Gold, 520 GMX2 Non O-Ring Chain) .....	<b>\$96.49</b>
GYT-ACC56-20-18 (Gold, 520 GMX2 Rivet Type Master Link) ..	<b>\$3.99</b>
GYT-ACC56-20-10 (Gold, 520 GMX2 Clip Type Master Link) ..	<b>\$2.99</b>
GYT-ACC56-20-11 (Natural, 520 GMX2 Non O-Ring Chain) ..	<b>\$87.49</b>
GYT-ACC56-20-17 (Natural, 520 GMX2 Rivet Type Master Link) ..	<b>\$3.99</b>
GYT-ACC56-20-12 (Natural, 520 GMX2 Clip Type Master Link) ..	<b>\$2.99</b>

**520 GMXL Non-Sealed (Non O-Ring) Chain Lite:**

- Displacement Limit: Up to 250cc
- Tensile strength = 6,600 lb
- 120 links
- Specifically designed for Motocross and Supercross
- Race-tested by Factory Riders to meet today's high performance machines
- Saves weight with less rotating mass
- High-tech CrH-coated pins for extremely hard outside surface and softer inside to increase the impact strength
- Includes clip and rivet type master link

GYT-OSS55-60-48 (Gold, 520 GMXL Non O-Ring Chain) .....	<b>\$101.49</b>
DBY-ACC56-34-45 (Gold, 520 GMXL Rivet Type Master Link) ..	<b>\$3.95</b>
GYT-OSS56-30-98 (Gold, 520 GMXL Clip Type Master Link) ..	<b>\$2.99</b>

*Make sure to check out Yamaha's full offering of maintenance products.*

COVERS

GRAPHICS

HANDLEBARS & CONTROLS

PERFORMANCE

PROTECTION

SEATS

SPROCKETS & CHAINS

TRIM & ACCENTS

WHEELS

**COVERS**

**GRAPHICS**

**HANDLEBARS & CONTROLS**

**PERFORMANCE**

**PROTECTION**

**SEATS**

**SPROCKETS & CHAINS**

**TRIM & ACCENTS**

**WHEELS**

**A. GYTR® 36MM TIMING PLUG**

These anodized 6061 billet aluminum timing plugs replace the stock plastic plugs.

*Fits '14~'17 YZ250F; '15~'17 YZ250FX*

**33D-E51A0-V0-00** (Blue)(Shown) .....\$38.99

*Fits '14~'17 YZ250F; '15~'17 YZ250FX*

**33D-E51A0-T0-00** (Black) .....\$38.99

**B. GYTR® 32MM TIMING COVER PLUG**

These anodized 6061 billet aluminum timing plugs replace the stock plastic plugs.

*Fits '08~'13 YZ250F*

**5XC-E51A0-V0-00** (Black) .....\$31.95

**GYT-5XC35-32-AL** (Blue) .....\$39.95

**C. GYTR® 14MM TIMING COVER PLUG**

These anodized 6061 billet aluminum timing plugs replace the stock plastic plugs.

*Fits '14~'16 YZ250F; '15~'17 YZ250FX*

**18P-E51B0-V0-00** (Red) .....\$30.95

**5XC-E51B0-V0-00** (Black) .....\$30.99

**GYT-2S235-14-AL** (Blue) .....\$28.99

**D. GYTR® MAGNETIC OIL DRAIN PLUG**

Replace the stock steel drain plug with this 6061 billet Magnetic Oil Drain Plug. 60% lighter than stock. Includes a magnet that collects metal shavings, preventing them from circulating in the motor oil. Used by Yamaha Racing Teams.

*Fits '07~'17 YZ250F; '15~'17 YZ250FX*

**18P-E51C0-U0-00** (Red) .....\$32.99

**E. GYTR® 20MM OIL FILL CAP**

Anodized 6061 billet aluminum plug replaces stock plastic cap.

*Fits '06~'17 YZ250F; '15~'17 YZ250FX*

**5XC-E53A0-V0-00** (Black) .....\$29.95

**GYT-2S235-01-00** (Blue) .....\$30.99

**F. GYTR® REAR BRAKE CLEVIS**

This billet rear brake clevis is machined to extremely tight tolerances which minimizes lateral movement or vibration of the rear brake pedal. This clevis allows for more height adjustment and features a titanium clevis pin that is half the weight of stock.

*Fits '09~'17 YZ250F; '15~'17 YZ250FX*

**5XC-F72A0-V0-00** (Blue) .....\$50.99

**G. GYTR® BRAKE LINE PINCH**

This pinch replaces the stock steel pinch with a blue anodized billet aluminum piece.

*Fits '06~'17 YZ250F; '15~'17 YZ250FX*

**GYT-1P818-15-00** (Blue) .....\$40.99

**H. GYTR® BILLET OFFSET AXLE BLOCKS**

These billet aluminum soft anodized axle blocks are reversible and offset and keep the adjustment bolts from extending too far back when running the rear wheel toward the back of the swingarm for maximum wheelbase.

*Fits '11~'17 YZ250F*

**33D-F53M0-T0-00** (Black) .....\$50.99

**33D-F53M0-V0-00** (Blue)(Shown) .....\$50.99

*Fits '15~'17 YZ250FX*

**GYT-2S299-10-00** (Blue) .....\$47.99

**I. YAMAHA KICKSTAND REMOVAL KIT (PEG MOUNT)**

Allows rider to remove the stock kickstand. Kit replaces the left side foot peg bracket. Kit includes the same components that come standard on YZ four-stroke models. The durability and quality you expect from Yamaha Genuine Parts.

*Fits '15~'17 YZ250FX*

**B91-F73A0-V0-00** .....\$25.99

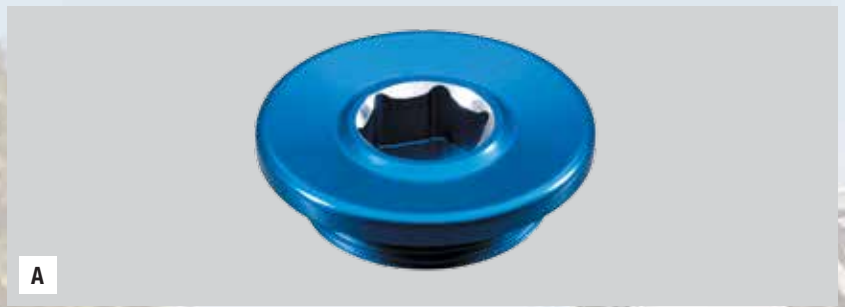

**A**

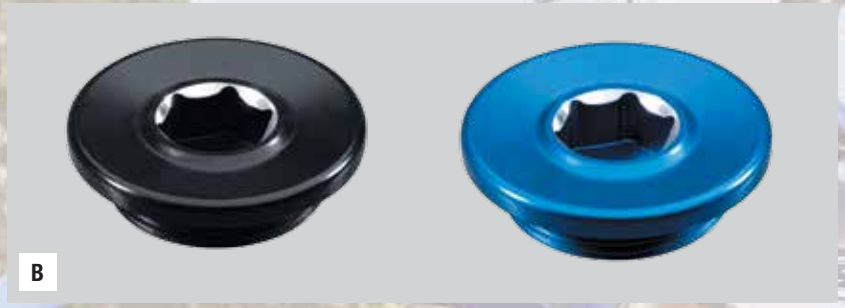

**B**

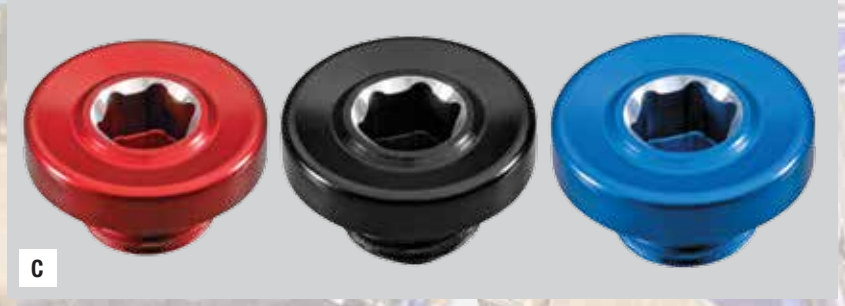

**C**



**D**



**E**



**F**



**G**



**H**



**I**



A

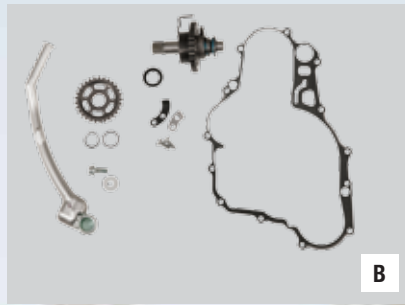

B

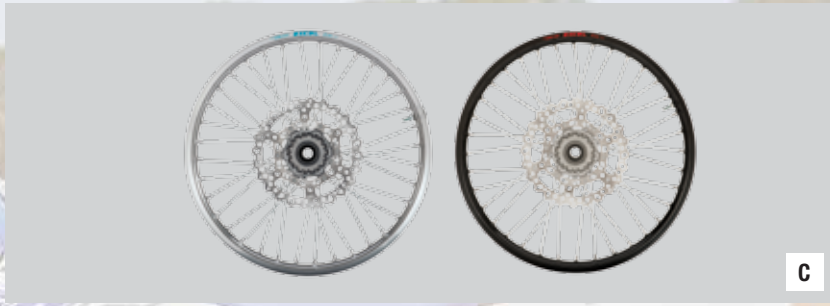

C



D



E



F



G

**A. YAMAHA KICKSTAND**

- Allows rider to distance themselves from the bike without a prop of some sort (tree, fence, rock, etc.)
- Replaces the left side foot peg bracket
- Same kickstand that comes standard on WR models, so you know you're getting a quality Yamaha factory part
- Durable aluminum construction with a secure attachment; doesn't clamp to the swingarm like other comparable products
- Lighter weight than other aftermarket options

Fits '14-'17 YZ250F  
**B11-F73A0-V0-00** .....\$144.99

**B. NEW! YAMAHA GENUINE KICK STARTER KIT**

This complete Kick Starter Kit includes all the components and gaskets needed to add kick start functionality to your 2017 YZ250FX.

- Includes necessary OE parts
- Dealer installation recommended

Fits '17 YZ250FX  
**B29-15602-00-00** .....\$210.95

**C. 21" FRONT WHEEL ASSEMBLY\***

These complete original-equipment wheel assemblies are available for Yamaha YZ & WR models. Wheels are factory assembled, ready for installation, and come complete with hub assemblies, spoke sets, rim locks, wave-style brake rotors, and oil seals. Front and rear assemblies are sold separately.

Fits '17 YZ250F  
**1SL-25102-00-00** (Silver) .....\$334.99  
**1SL-25102-10-00** (Black) .....\$360.99

Fits '15-'17 YZ250FX  
**B29-25102-00-00** .....\$334.99

Fits '02-'13 YZ250F  
**5XC-W2519-L0-00** (Silver) .....\$345.99

**D. 19" REAR WHEEL ASSEMBLY\***

Wheels are factory assembled, ready for installation, and come complete with hub assemblies, spoke sets, rim locks, wave-style brake rotors, and oil seals.

**NOTE:** 2014 YZ250F/ YZ450F is compatible with rear wheel only.

Fits '09-'17 YZ250F  
**17D-25302-60-00** (Black) .....\$551.99

Fits '09-'17 YZ250F  
**17D-W2539-40-00** (Silver) .....\$519.99

Fits '02-'08 YZ250F  
**5XC-W2539-L0-00** (Silver) .....\$535.99

**E. GYTR® BILLET WHEEL SPACER KIT**

Get Yamaha Racing Team looks and function with these billet wheel spacers that have integrated dust covers and a seal lip that helps keep the spacers in place during wheel installation/removal.

Fits '07-'13 YZ250F  
**5XC-F51A0-V0-00** (Blue) (Front) .....\$40.99

**F. WHEEL SPACERS BY ZETA HIGH PERFORMANCE PRODUCTS**

Products features: lightweight aluminum construction, and blue-anodized enhanced styling. Installs in minutes.

Fits '14-'17 YZ250F; '15-'17 YZ250FX  
**DBY-ACC56-34-67** (Front) (Shown) .....\$11.95

Fits '15-'17 YZ250FX; '06-'08 YZ250F  
**DBY-ACC56-34-68** (Rear) .....\$11.95

Fits '09-'17 YZ250F  
**DBY-ACC56-34-84** (Rear) .....\$12.99

**G. SUNLINE® RIM LOCK TOWER NUTS**

Machined from aircraft grade 6061-T6 aluminum. Closed nut design seals out mud and water, helping to prevent corrosion. Bevel washer design seats on the rim for a secure fit. Brilliant anodized finish.

Fits all YZ & WR models  
**GYT-OSS55-60-23** (Blue) .....\$20.95

COVERS

GRAPHICS

GRAPHICS

PERFORMANCE

PROTECTION

SEATS

SPROCKETS & CHAINS

TRIM & ACCENTS

WHEELS

**COVERS**

**HANDLEBARS & CONTROLS**

**PERFORMANCE**

**PROTECTION**

**SEATS**

**SPROCKETS & CHAINS**

**TRIM & ACCENTS**

**WHEELS**

**A. NEW! MOTORCYCLE COVER**

Keep your dirtbike protected from dust at the track or in your garage with this Yamaha cover.

- Traditional Yamaha racing blue color featuring the GYTR, Yamalube and bLU cRU logos
- Lightweight material that can be quickly rolled up into the convenient attached storage bag
- Water resistant
- Equipped with a drawstring at the bottom to keep the cover in place

**NOTE:** Recommended for storage use only; not for trailering or transport

*Fits all WR models*

**1SL-F81A0-V0-00** (Blue) .....\$69.99

**B. GYTR® PIVOTING BRAKE LEVER BY ARC™**

GYTR Pivoting Levers are designed with a folding-pivot blade that will fold in the event of a tip-over. Pivot ratio mimics stock for excellent performance.

*Fits '16 WR450F; '15-'16 WR250F*

**2GB-H39A0-V0-00** (Black) (Brake).....\$78.99

*Fits '05-'15 WR450F; '05-'13 WR250F*

**GYT-5XC37-30-00** (Black) (Brake) .....\$75.99

*Fits '16 WR450F; '15-'16 WR250F*

**2GB-H39B0-V0-00** (Black) (Clutch).....\$72.99

**C. SCOTT® MX2 GRIPS**

Scott® MX2 Grips are designed for superior grip and comfort. The grips feature underside waffle and soft-ridged upper patterns. They are grooved for safety wire, race proven and sold in pairs.

*Fits '03-'17 WR450F; '02-'17 WR250F*

**ABA-YZRMX-GP-BK** (Black) .....\$9.99

**D. GYTR® CROSSBAR PAD**

Designed for handlebars with crossbar. Printed on scratch resistant, 15 mil. vinyl featuring the Yamaha logo. Fits all Off-Road Motorcycles with 7/8" handlebars. 11" long.

*Fits all Off-Road Models w/ crossbar-equipped handlebars*

**GYT-CROSS-BR-02** (Blue).....\$12.99

**E. GYTR® YAMAHA FACTORY RACING CLAMP COVER FOR 1-1/8" HANDLEBARS**

Printed on scratch-resistant 15-mil vinyl, featuring the Factory Racing logo. 10" long. For 1-1/8" handlebars.

*For all Off-road Motorcycles with 1-1/8" handlebars*

**GYT-5XC25-18-BL** (Blue).....\$21.99



**A**



**B**



**C**



**D**



**E**



A

**A. GPR® STEERING STABILIZER**

GPR® Stabilizers are precision-machined for proven reliability and superior quality. Kit comes with the GPRV1 stabilizer and billet-machined mounting brackets. The patented "pin-less" mounting brackets eliminates any slop that might normally exist with the traditional aftermarket pin-and-slot mounting systems. Easy installation provides bolt-on performance. No drilling, tapping, or welding required. Intended to fit with OEM bars.

*Fits '17 WR450F; '15-'17 WR250F*  
**DBY-ACC56-34-63** .....\$495.00

**B. CYCRA® SERIES ONE PROBEND® HAND GUARDS**

Cycra® blended the best features of a straight bar and the classic Probend®, to result in the Series One Probend®. Many riders prefer the straight bar end with more of a closed-in area but still want ample room for levers, hands, and controls. Cycra® was able to accommodate both by adding a subtle drop in the bar end. Requires "U" Clamp Set (sold separately) for specific type of handlebar.

*Fits '05-'17 WR450F; '05-'17 WR250F*  
**DBY-ACC56-34-02** (White) .....\$64.95  
**DBY-ACC56-34-03** (Blue) .....\$65.49  
**DBY-ACC56-34-01** (Black) .....\$64.95

**C. CYCRA® REBOUND HAND SHIELDS**

Unrivaled strength against trail debris. Vigorously tested for durability and quality assurance. Great alternative to wraparound systems for woods or MX. Patented folding shield for those unexpected obstacles or accidental falls. Billet aluminum mounts and reinforced backbone on shield. In-molded rubber edge provides increased protection. Can be mounted over or under bars for easy installation and clean hand control area. Includes shields, mounts, and hardware. Sold in pairs.

*Fits '05-'17 WR450F; '05-'17 WR250F*  
**DBY-ACC56-34-72** (White) .....\$79.99  
**DBY-ACC56-34-73** (Blue) .....\$79.99  
**DBY-ACC56-34-71** (Black) .....\$79.99



B



C

COVERS

HANDLEBARS & CONTROLS

PERFORMANCE

PROTECTION

SEATS

SPROCKETS & CHAINS

TRIM & ACCENTS

WHEELS

COVERS

HANDLEBARS & CONTROLS

PERFORMANCE

PROTECTION

SEATS

SPROCKETS & CHAINS

TRIM & ACCENTS

WHEELS

**A. CYCRA® ALLOY STEALTH COMPLETE RACER PACK**

Complete Racer Pack includes shields, brackets, and hardware. Aircraft quality 6061 T-6 aluminum brackets. Slim, low-profile handshield design. Simple and easy to install. Rotating bolt plate allows brackets to be mounted above or below levers.

*Fits all 2-stroke and 4-stroke WR models except WR250R/WR250X*

GYT-OSS56-30-59 (Black) .....	\$51.95
GYT-OSS56-30-60 (White) .....	\$51.95
GYT-OSS56-30-61 (Blue) .....	\$51.95

**B. CYCRA® CENTER REACH MOUNT COMPLETE RACER PACK**

These Center Reach Mount (CRM) Complete Racer Packs include CRM ProBend® bars, CRM mount clamps, classic Enduro™ shields, Powergrip bar ends, and ProBend® abrasion guards. Revolutionary patent-pending design. Trademark ProBend® shape. Replaceable integrated plastic abrasion guard. Center-reach clamps provide maximum bite to secure hand guards and allow for superior clearance on a wide range of bars. Powergrip alloy bar ends fit 1-1/8" oversized bars. Some control adjustments may be necessary.

*Fits all WR450F and WR250F*

GYT-OSS56-30-48 (White) .....	\$132.95
GYT-OSS56-30-49 (Blue) .....	\$132.95

**C. CYCRA® FACTORY PROBEND® CRM RACER PACK**

Exclusive Yamaha color way and shield graphics. Factory Edition ProBend® CRM Complete Racer Pack includes center reach bars, center reach mounting clamps, classic Enduro shields, Powergrip alloy bar ends, and all necessary hardware. Revolutionary patented billet construction. Trademarked ProBend® shape. Replaceable integrated plastic abrasion guard; center reach clamps provide maximum bite to secure hand guards and allows for superior clearance on a wide range of bar. Powergrip alloy bar ends fit standard and oversized bars. Sold in pairs.

*Fits '05-'17 WR450F; '05-'17 WR250F*

DBY-ACC56-34-69 (White) .....	\$169.99
DBY-ACC56-34-70 (Blue) .....	\$169.99



A



B



C



COVERS

HANDLEBARS & CONTROLS

PERFORMANCE

PROTECTION

SEATS

SPROCKETS & CHAINS

TRIM & ACCENTS

WHEELS



A

**A. CYCRA® SERIES ONE PROBEND® BAR "U" CLAMP SET**

U Clamp Set for ProTaper® Pre-2007/Renthal® Fatbar®/Tag T2 Handlebars. To be used with DBY-ACC56-34-01, DBY-ACC56-34-02 or DBY-ACC56-34-03

*Fits '05-'17 WR250F*  
**DBY-ACC56-34-04 (Natural)** .....\$36.49

U Clamp set for 7/8" bars. To be used with DBY-ACC56-34-01, DBY-ACC56-34-02 or DBY-ACC56-34-03

*Fits '05-'17 WR250F*  
**DBY-ACC56-34-05 (Natural)** .....\$44.95

U Clamp Set for ProTaper® Evo and Contour/Neken. To be used with DBY-ACC56-34-01, DBY-ACC56-34-02 or DBY-ACC56-34-03

*Fits '05-'17 WR250F*  
**DBY-ACC56-34-06 (Natural)** .....\$44.95

**B. ATHENA® 290CC BIG BORE KIT**

Big Bore Cylinder Kits include brand new nickel-carbide plated cylinder with enlarged water passages, precision made piston with rings, pins, clips, gaskets, O-rings, and all other parts needed for a complete installation. This accessory is restricted to closed-course use on 2006 and newer models.

*Fits '01-'12 WR250F*  
**GYT-OSS56-31-08** .....\$803.95

**C. ATHENA® 290CC BIG BORE KIT - PISTON KIT A**

Big Bore Cylinder Kits include brand new nickel-carbide plated cylinder with enlarged water passages, precision made piston with rings, pins, clips, gaskets, O-rings, and all other parts needed for a complete installation. This accessory is restricted to closed-course use on 2006 and newer models.

*Fits '01-'12 WR250F*  
**GYT-OSS56-31-09** .....\$209.95

**D. ATHENA® 290CC BIG BORE KIT - PISTON KIT B**

Big Bore Cylinder Kits include brand new nickel-carbide plated cylinder with enlarged water passages, precision made piston with rings, pins, clips, gaskets, O-rings, and all other parts needed for a complete installation. This accessory is restricted to closed-course use on 2006 and newer models.

*Fits '01-'12 WR250F*  
**GYT-OSS56-31-10** .....\$209.95

**E. ATHENA® 290CC BIG BORE KIT - GASKET KIT**

Big Bore Cylinder Kits include brand new nickel-carbide plated cylinder with enlarged water passages, precision made piston with rings, pins, clips, gaskets, O-rings, and all other parts needed for a complete installation. This accessory is restricted to closed-course use on 2006 and newer models.

*Fits '01-'12 WR250F*  
**GYT-OSS56-31-11** .....\$66.99

**F. ATHENA® 290CC BIG BORE KIT - RING SET**

Big Bore Cylinder Kits include brand new nickel-carbide plated cylinder with enlarged water passages, precision made piston with rings, pins, clips, gaskets, O-rings, and all other parts needed for a complete installation. This accessory is restricted to closed-course use on 2006 and newer models.

*Fits '01-'12 WR250F*  
**GYT-OSS56-31-12** .....\$30.49

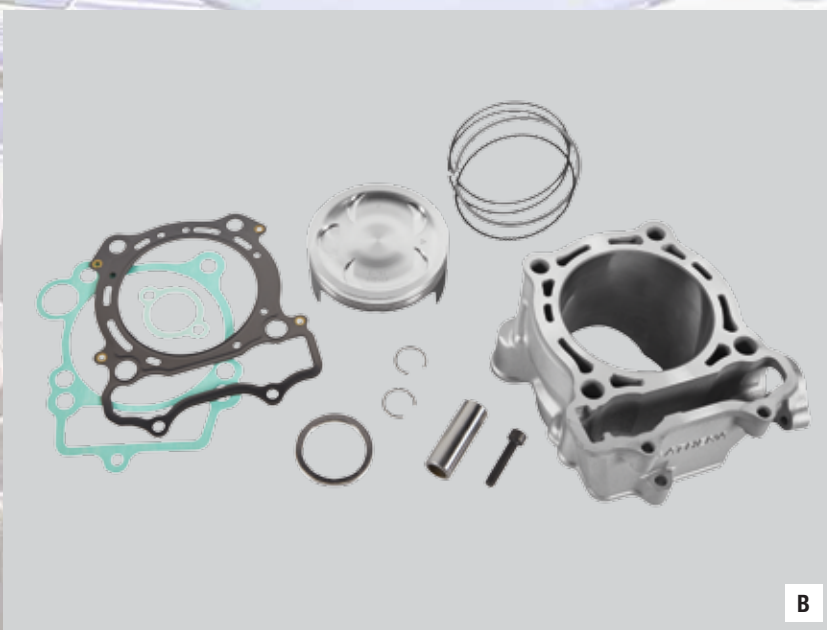

B



C



D

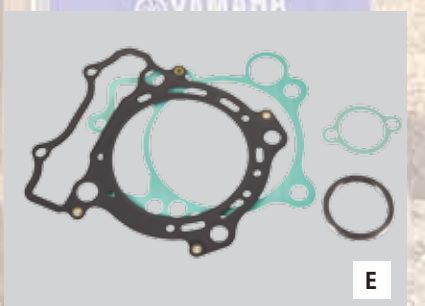

E

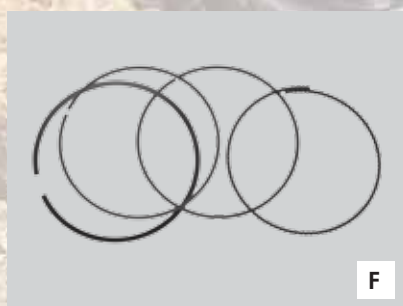

F

COVERS

HANDLEBARS & CONTROLS

PERFORMANCE

PROTECTION

SEATS

SPROCKETS & CHAINS

TRIM & ACCENTS

WHEELS

**A. YAMAHA GENUINE GASKET KIT**

These original-equipment Top End and Bottom End Gasket Kits were designed for convenience and total savings. Kits include the necessary gaskets, seals, and O-rings needed to reassemble your engine. They also include a complete part number list of all gaskets, seals, and O-rings for an in-depth engine overhaul.

*Fits '16~'17 WR450F*

<b>1SL-W0001-00-00</b> (Top End) .....	<b>\$51.52</b>
<b>B11-W0002-00-00</b> (Bottom End) .....	<b>\$84.60</b>

*Fits '15~'17 WR250F*

<b>1SM-W0001-00-00</b> (Top End) .....	<b>\$73.32</b>
<b>1SM-W0002-00-00</b> (Bottom End) .....	<b>\$40.56</b>

*Fits '07~'15 WR450F*

<b>2S2-W0001-10-00</b> (Top End) .....	<b>\$69.99</b>
<b>2S2-W0002-10-00</b> (Bottom End) .....	<b>\$59.95</b>

*Fits '01~'14 WR250F*

<b>5NL-W0001-00-00</b> (Top End) (Shown) .....	<b>\$73.99</b>
<b>5NL-W0002-00-00</b> (Bottom End) .....	<b>\$89.99</b>

*Fits '03~'06 WR450F*

<b>5TA-W0001-00-00</b> (Top End) .....	<b>\$100.99</b>
<b>5TG-W0002-00-00</b> (Bottom End) .....	<b>\$100.99</b>

**B. GYTR® PERFORMANCE HIGH-FLOW AIR FILTER**

High-flow, two-layer foam filter offers optimized filtration while maximizing airflow. Increases performance. Filter is completely washable and reusable. Service with Yamaha Genuine Foam Filter Oil. This accessory is restricted to closed-course use.

*Fits '16~'17 WR450F; '17 WR250F*

<b>1SL-E41C0-V0-00</b> .....	<b>\$27.99</b>
------------------------------	----------------

**C. YAMAHA AIR BOX WASH CAP**

Eases air box cleaning and leaves no gaps that would allow water to penetrate when used. Features a large, tool-less knob and is made of ABS plastic with a fully sealed rubber gasket on the leading edge. It is easy to install and remove.

*Fits '16~'17 WR450F; '15~'16 WR250F*

<b>1SL-E41E0-V0-00</b> .....	<b>\$38.99</b>
------------------------------	----------------

**D. GYTR® TWO-STAGE FOAM AIR FILTER**

High-flow, two-layer foam filter offers optimized filtration while maximizing airflow. Increases performance. Filter is completely washable and reusable. Service with Yamaha Genuine Foam Filter Oil. This accessory is restricted to closed-course use.

*Fits '07~'15 WR450F; '07~'13 WR250F*

<b>GYT-5TJ95-00-00</b> .....	<b>\$33.95</b>
------------------------------	----------------

**E. GYTR® BY FMF® MEGABOMB® HEAD PIPE**

The GYTR by FMF® MegaBomb® Head Pipe can provide as much as a 3 hp boost, plus the MegaBomb® actually reduces noises levels by as much as 1.5 dBA. The MegaBomb® is designed to perform at the world's highest levels of racing. It produces long header torque and short header over-rev. This accessory is restricted to closed-course use.

*Fits '16~'17 WR450F*

<b>1SL-E46A0-T0-00</b> (Stainless Steel) (Shown) .....	<b>\$357.99</b>
<b>1SL-E46A0-V0-00</b> (Titanium) .....	<b>\$449.99</b>

*Fits '15~'17 WR250F*

<b>1SM-E46A0-T0-00</b> (Stainless Steel) .....	<b>\$357.99</b>
<b>1SM-E46A0-V0-00</b> (Titanium) .....	<b>\$463.99</b>

**F. GYTR® BY FMF® POWERBOMB® HEAD PIPE**

The Stainless Steel PowerBomb® is a four-stroke header that incorporates the patented PowerBomb® module at a precise location in the initial stage of the header. By positioning this "Bomb" at a key point in the system, increased performance and flow is achieved through the expansion and contraction of exhaust sonics through the system. The result is a flow increase of nearly 10%! The outer chamber in the PowerBomb® allows the air to expand, cool, and ramp back up at a higher velocity. Additionally, the PowerBomb® is a "pre-muffler" of sorts, which helps to lower the bike's sound output by providing more sound absorbing surface area for the sound medium (exhaust gases). The PowerBomb® provides power focused in the mid to upper rpm range. This accessory is restricted to closed-course use.

*Fits '07~'15 WR450F*

<b>2S2-E46A0-V0-00</b> (Stainless Steel) .....	<b>\$199.99</b>
--	-----------------

*Fits '01~'13 WR250F*

<b>5XC-E46A0-V0-00</b> (Stainless Steel) .....	<b>\$199.99</b>
--	-----------------



A



B



C



D



E



F



A



B



C



D



E



F

**A. GYTR® BY FMF® ALUMINUM POWERCORE® 4 HEX MUFFLER**

The PowerCore®4 is designed to increase the horsepower and torque throughout the entire power curve and give you a noticeable power increase that is very usable and beneficial, no matter your riding style or ability. Features include space age internal packing for maximum packing life and a high-flow modular end cap. Internal core shape uses high-flow technology. Enhanced sonic evacuation provides for higher flow and increased power. Muffler includes removable spark arrestor. 97.5 dBA sound level. 95.5 dBA with QuietCore™ Spark Arrestor Insert, sold separately. This accessory is restricted to closed-course use.

*Fits '16-'17 WR450F*  
**1SL-E47A0-T0-00** (Aluminum).....\$336.99

*Fits '15-'17 WR250F*  
**1SM-E47A0-T0-00** (Aluminum) (Shown).....\$336.99

*Fits '09-'12 WR250F*  
**2S2-E47A0-VI-00** (Aluminum).....\$329.99

*Fits '12-'15 WR450F*  
**1DX-E47A0-VI-00** (Aluminum).....\$329.99

**B. GYTR® BY FMF® TITANIUM RCT FACTORY 4.1™ MUFFLER**

The patented FMF® Resonance Chamber Technology enhances and refines exhaust pressure. Its patented core shape lowers sound level while maintaining maximum power output, and the patented canister shape increases internal volume for more sound-absorbing material. Factory Forward Engineering centralizes mass and is less prone to impact damage.

- Maintenance is easy—Remove four screws on the front end cap, and the innovative rear end cap simplifies the installation of the spark arrestor (sold separately) or tuning tip inserts
- Includes QuietCore™ 94 dBA insert. Meets AMA® and FIM sound requirements
- It is compatible with stock or FMF® header and made in the U.S.A.
- This accessory is restricted to closed-course use

*Fits '17 WR450F*  
**1SL-E47A0-V0-00** (Titanium) (Shown).....\$612.99

*Fits '15-'17 WR250F*  
**1SM-E47A0-V0-00** (Titanium).....\$599.99

**C. GYTR® BY FMF® FACTORY 4.1™ MUFFLER**

This Factory 4.1™ Muffler incorporates the latest FMF® Resonance Chamber Technology®. The patented chamber design enhances and refines exhaust pressure. Its patented core shape lowers sound level while maintaining maximum power output, and the patented canister shape increases internal volume for more sound-absorbing material. Factory Forward Engineering centralizes mass and is less prone to impact damage.

Maintenance is made easy with the removal of four screws on the front end cap, and the innovative rear end cap simplifies installation of the spark arrestor (sold separately) or tuning tip inserts. Includes QuietCore™ 94 dBA insert. Meets AMA® and FIM sound requirements. Compatible with stock or FMF® header. Built 100% in the U.S.A. This accessory is restricted to closed-course use.

*Fits '07-'15 WR450F; '07-'13 WR250F*  
**2S2-E47A0-T0-00** (Aluminum).....\$499.99

**D. GYTR® PERFORMANCE WR MUFFLER INSERT**

The GYTR Quiet Performance Muffler Insert is designed to be used with the stock exhaust system. This muffler offers a power increase while allowing your muffler to pass the 96 dBA 20" stationary test. This accessory is restricted to closed-course use on 2006 and newer models.

*Fits '05-'17 WR450F; '09-'17 WR250F*  
**GYT-5TJ93-75-01**.....\$52.99

**E. GYTR® BY FMF® QUIETCORE™ SPARK ARRESTOR INSERT**

Noise-reducing inserts with spark arrestors.

*Fits '09-'17 WR450F; '09-'17 WR250F*  
**33D-E46C0-T0-00**.....\$39.99

**F. GYTR® BY FMF® REPLACEMENT SPARK ARRESTOR INSERT**

The GYTR® by FMF® Replacement Spark Arrestor Insert is designed to fit the GYTR by FMF® PowerCore®4 Mufflers.

*Fits '07-'17 WR450F; '07-'17 WR250F*  
**33D-E46C0-V0-00**.....\$30.99

COVERS

HANDLEBARS & CONTROLS

PERFORMANCE

PROTECTION

SEATS

SPROCKETS & CHAINS

TRIM & ACCENTS

WHEELS

COVERS

HANDLEBARS & CONTROLS

PERFORMANCE

PROTECTION

SEATS

SPROCKETS & CHAINS

TRIM & ACCENTS

WHEELS

**A. WR AIR INDUCTION SYSTEM REMOVAL KIT**

Allows you to remove the Air Induction System for lighter weight and added performance on WR models. This accessory is restricted to closed-course use.

<i>Fits '05~'13 WR250F</i>	<b>GYT-5UM93-69-01</b> .....	<b>\$73.99</b>
<i>Fits '07~'11 WR450F</i>	<b>GYT-5TJ93-69-01</b> .....	<b>\$61.99</b>
<i>Fits '05~'06 WR450F</i>	<b>GYT-5TJ93-69-00</b> .....	<b>\$65.99</b>

**B. GYTR® BILLET CLUTCH BASKET**

The GYTR Billet Clutch Basket is precision machined from the highest grade of aluminum and then anodized to achieve an exceptionally hard, wear-resistant surface. This clutch basket provides amazing, race-proven durability.

<i>Fits '07~'15 WR450F</i>	<b>GYT-5XD56-10-00</b> .....	<b>\$226.99</b>
<i>Fits '15~'17 WR250F</i>	<b>1SM-E63A0-V0-00</b> .....	<b>\$224.99</b>
<i>Fits '01~'13 WR250F</i>	<b>GYT-5XC56-10-00</b> .....	<b>\$239.95</b>

**C. GYTR® BILLET INNER CLUTCH HUB**

The GYTR Billet Clutch Inner Hub is precision machined from the highest grade of aluminum, then hard anodized to achieve an exceptionally hard wear-resistant surface. Additional oil passages help improve clutch performance and contribute to a 20% weight reduction and less rotational mass for improved acceleration.

<i>Fits '10~'17 WR450F</i>	<b>GYT-5XD56-40-00</b> .....	<b>\$297.99</b>
<i>Fits '15~'17 WR250F</i>	<b>1SM-E63C0-V0-00</b> .....	<b>\$286.99</b>

**D. GYTR® BILLET CLUTCH PRESSURE PLATE**

Precision-machined from the highest grade of aluminum, then hard anodized to achieve an exceptionally hard, wear-resistant surface for amazing race-proven durability. Additional oil passages help improve clutch performance and also contribute to a 30% weight reduction and less rotational mass for improved acceleration.

<i>Fits '03~'17 WR450F</i>	<b>GYT-5XD56-20-00 (Shown)</b> .....	<b>\$169.99</b>
<i>Fits '15~'17 WR250F</i>	<b>1SM-E63B0-V0-00</b> .....	<b>\$164.99</b>
<i>Fits '01~'13 WR250F</i>	<b>GYT-5XC56-20-00</b> .....	<b>\$166.95</b>

**E. YAMAHA GENUINE OFF-ROAD CLUTCH KITS**

These complete Yamaha Clutch Kits include the plates, springs, and gaskets, ready to install. Refer to service manual for installation instructions.

<i>Fits '16~'17 WR450F</i>	<b>2GC-W001G-00-00</b> .....	<b>\$164.99</b>
<i>Fits '15~'17 WR250F</i>	<b>2GB-W001G-00-00</b> .....	<b>\$164.99</b>
<i>Fits '05~'15 WR450F</i>	<b>5TJ-W001G-00-00</b> .....	<b>\$164.99</b>
<i>Fits '01~'14 WR250F</i>	<b>5UM-W001G-00-00</b> .....	<b>\$167.99</b>

**F. GYTR® BILLET CLUTCH COVER**

GYTR Clutch Components are precision machined from aerospace-quality aluminum alloys with a unique hard coating. This provides superior performance and clutch feel, as well as excellent component durability. The patent-pending "auto oiling system" forces oil through specially cut holes in the pressure plate, into the inner hub, and then to the clutch plates. This results improved clutch performance, with lower clutch temperatures, less clutch expansion and extended clutch life.

<i>Fits '16~'17 WR450F</i>	<b>33D-E54E0-V0-00</b> .....	<b>\$148.99</b>
<i>Fits '08~'15 WR450F</i>	<b>GYT-5XD35-10-AL (Shown)</b> .....	<b>\$148.99</b>
<i>Fits '15~'17 WR250F</i>	<b>1SM-E54E0-V0-00</b> .....	<b>\$145.99</b>
<i>Fits '01~'13 WR250F</i>	<b>17D-E54E0-V0-00</b> .....	<b>\$143.95</b>



A



B



C



D



E



F



A



B



C



D



E

**A. GYTR® COMPETITION KIT**

The Competition Kit replaces the stock ECU and includes a new throttle stop to allow wide open throttle.

- Kit includes YZ style throttle screw
- Allows ECU adjustments via the GYTR Power Tuner (sold separately)
- Specific maps for tuning capabilities available for free on the GYTR Power Tuner product page on [shopyamaha.com](http://shopyamaha.com)

*This accessory affects emissions; installation on EPA-regulated 2006 or later WR models constitutes unlawful tampering except when used solely for closed-course competition.*

Fits '16~'17 WR450F  
**2GC-E9500-V0-00** .....\$113.99

Fits '12~'15 WR450F  
**1DX-H59C0-V0-00** .....\$110.99

Fits '15~'17 WR250F  
**2GB-E9500-V0-00 (Shown)** .....\$113.99

**B. GYTR® POWER TUNER**

This easy plug-in fuel-injection and ignition tuning tool allows riders to quickly adjust the fuel and ignition maps to suit riding conditions and rider preference. Allows nine easy-to-program adjustment points for both the fuel and ignition maps. Monitor function allows user to monitor the data from various sensors on the bike as well as adjust idle timing, see engine running time, and self-diagnosis function. Powered by two AA batteries, thus no laptop or time consuming downloads necessary. Unit does not have to be plugged into bike to create maps. Compact design can fit in the palm of your hand, pocket, etc. Memory function can save up to nine custom maps.

Fits '12~'17 WR450F with GYTR Competition Kit/ECU; '15~'17 WR250F with GYTR Competition Kit/ECU  
**33D-H59C0-V1-00** .....\$298.99

**C. OVERSIZED FUEL TANKS BY IMS**

This tanks is designed to carry more fuel and enhance the appearance of your motorcycle. Larger capacity than stock, yet very slim and sleek. Provides greater riding distance per full tank. Perfect for enduros or hare scrambles where the extra distance can mean the difference between winning and losing. The tanks are made with Polyethylene Crosslink for extra strength and durability. Suitable for WR motorcycles used only for closed-course competition.

Fits '16~'17 WR450F; '15~'17 WR250F  
**DBY-ACC56-34-81 (3.0 gal) (Natural)** .....\$274.99

Fits '12~'15 WR450F  
**DBY-ACC56-34-46 (3.0 gal) (White)** .....\$269.49

**D. GYTR® KICK START REMOVAL KIT**

Allows customer to remove the kick start lever, shaft, and gear. Kick Start lever can always be re-installed on the bike at a later date, if desired.

Fits '16~'17 WR450F  
**B91-E57A0-V0-00** .....\$30.99

Fits '15~'17 WR250F  
**B29-E57A0-V0-00** .....\$30.99

**E. YAMAHA GENUINE FRONT FORK SEAL KIT**

These Yamaha Genuine Fork Seal Kits come with the original equipment fork and dust seats. Don't settle for the next best thing from the aftermarket; use Yamaha Genuine Fork Seal Kits for longer life and less maintenance. Don't forget to order the proper fork oil for your bike, as well. Yamaha Fork Oils are formulated specifically for your model and deliver the highest suspension performance possible.

Fits '15~'16 WR450F; '12~'16 WR250F  
**17D-W003B-00-00** .....\$67.99

Fits '05~'11 WR450F; '05~'14 WR250F  
**1C3-W003B-00-00** .....\$67.99

Fits '03~'04 WR450F; '03~'04 WR250F; '01~'02 WR426F  
**5ET-W003B-00-00** .....\$62.99

COVERS

HANDLEBARS & CONTROLS

PERFORMANCE

PROTECTION

SEATS

SPROCKETS & CHAINS

TRIM & ACCENTS

WHEELS

**COVERS**

**HANDLEBARS & CONTROLS**

**PERFORMANCE**

**PROTECTION**

**SEATS**

**SPROCKETS & CHAINS**

**TRIM & ACCENTS**

**WHEELS**

**A. FORK BLEEDERS BY MOTION PRO®**

The Fork Bleeders by Motion Pro® features:

- Releases trapped air in forks with push of a button
- Small unobtrusive profile
- Installs in minutes
- Fits any bike with a 5mm x 0.08 thread pitch

*Fits '09~'17 WR450F; '09~'13 WR250F*  
**DBY-ACC56-34-66.....\$15.99**



**A**

**B. YAMAHA GENUINE BEARING KITS**

These Yamaha Genuine Bearing Kits come with all of the components needed to rebuild the swingarm pivot, shock linkage, and shock bearings. Kits include all of the original equipment bearings, seals, O-rings, and collars your bike came with. Unlike some of the aftermarket companies that use a lower quality bearing, these bearings are O-ring sealed to prevent intrusion of dirt, mud, and water and are made of top quality materials. So, if you don't want to do the job again and in half the time your original bearings lasted, then use these Yamaha Genuine kits.

*Fits '15~'17 WR250F*  
**33D-W002C-00-00 (Swingarm Pivot Bearing Kits).....\$81.99**

*Fits '16 WR450F; '15~'17 WR250F*  
**33D-W002E-00-00 (Shock Linkage Bearing Kits).....\$89.99**

*Fits '16 WR450F; '15~'17 WR250F;*  
**1SS-W002G-00-00 (Shock Bearing Kits).....\$77.99**

*Fits '07~'15 WR450F; '07~'14 WR250F*  
**1HC-W002E-00-00 (Shock Linkage Bearing Kits).....\$89.99**

*Fits '07~'15 WR450F; '07~'14 WR250F*  
**1C3-W002G-00-00 (Shock Bearing Kits).....\$62.99**

*Fits '06~'15 WR450F; '06~'14 WR250F*  
**1HC-W002C-00-00 (Pivot Bearing Kits).....\$81.99**

*Fits '05~'06 WR450F/ WR250F*  
**5TJ-W002G-00-00 (Shock Bearing Kits).....\$65.99**



**B**

**C. GYTR® BY BRAKING™ SOLID REAR BRAKE ROTOR**

The GYTR by BRAKING™ Solid Rear Brake Rotor is a high quality, durable, and slot-less brake rotor. This rotor helps to extend brake pad life in muddy conditions.

*Fits '06~'17 WR450F; '06~'17 WR250F*  
**1SL-F5860-V0-00.....\$107.99**



**C**

**D. STAINLESS STEEL BRAIDED BRAKE LINES**

These top-quality brake lines are designed to not fatigue even under extreme conditions.

*Fits '09~'17 WR450F; '09~'17 WR250F*  
**17D-F58E0-V0-00 (Front).....\$66.99**

*Fits '09~'11 & '16~'17 WR450F; '15~'17 WR250F*  
**5XC-F58A0-V0-00 (Rear) (Shown).....\$61.99**



**D**

**E. GYTR® RADIATOR BRACES**

These GYTR radiator cages offer another level of protection against serious radiator damage.

- Full cage with rod design
- Lightweight yet sturdy constructed with stamped 3.2mm aluminum to provide strength and protection in the event of side impacts
- No modifications necessary
- Easy-to-install design means radiator removal is not required
- Installs in minutes

*Fits '16~'17WR450F; '15~'17 WR250F*  
**2GB-E24C0-V0-00 (Shown).....\$133.99**

*Fits '12~'15 WR450F*  
**1DX-E24C0-V0-00.....\$111.99**

*Fits '07~'13 WR250F*  
**5UM-E24C0-V0-00.....\$107.95**



**E**



**F**

**F. GYTR® PLASTIC CHAIN GUIDE**

GYTR Plastic Chain Guide is ultra-durable. The plastic guide is designed to flex, not bend, in the event of impact.

*Fits '07~'17 WR450F/ WR250F*  
**17D-F21E0-V0-00 (Black).....\$88.99**



**A. CARBON FIBER REAR CALIPER GUARD BY LIGHTSPEED®**

Durable, lightweight carbon fiber design helps protect your rear brake caliper.

Fits '06~'17 WR450F; '06~'17 WR250F

GYT-OSS56-30-27 .....\$46.95

**B. GYTR® PLASTIC REAR BRAKE GUARD**

The GYTR Rear Brake Disc Guard is made of ultra-durable UHMWPE (Ultra High Molecular Weight Polyethylene). This disc guard is designed to flex and not bend upon impact. Improved durability in gnarly off-road conditions. Machined collars and OE style hardware allows for easy, same tool installation.

Fits '07~'17 WR450F

1DX-F58FO-V0-00 .....\$108.95

**C. CARBON FIBER REAR CALIPER GUARD & DISC GUARD SET BY LIGHTSPEED®**

This kit includes carbon fiber components that will help protect the rear brake disc and caliper. Sold as a set.

Fits '06~'17 WR450F; '06~'17 WR250F

GYT-OSS56-30-28 .....\$97.95

**D. CARBON FIBER FRONT DISC GUARD BY LIGHTSPEED®**

Carbon fiber construction provides the ultimate combination of a lightweight yet super strong part. Directional venting aids heat reduction, reducing brake fade. Kevlar® reinforcement patch placed in strategic areas to aid in durability. Helps protect the front brake disc. Will work on oversized brake rotors up to 295mm.

Fits '06~'17 WR450F; '06~'17 WR250F

GYT-OSS56-30-29 .....\$108.49

**E. GYTR® ALUMINUM SKID PLATE**

This aluminum plate is designed with side skirts to help protect the lower frame rails, critical engine components, water pump, ignition cover, and clutch components even on the gnarliest enduro course.

Fits '16~'17 WR450F; '15~'17 WR250F

2GB-F14B0-V0-00 .....\$128.99

**F. ENDURO™ SKID PLATE**

This aluminum plate is designed with side skirts to help protect the lower frame rails, critical engine components, water pump, ignition cover, and clutch components even on the gnarliest enduro course.

Fits '12~'15 WR450F

1DX-F14B0-V0-00 (Aluminum) (Shown) .....\$123.95

Fits '07~'11 WR450F; '07~'13 WR250F

GYT-5UM34-80-00 (Aluminum) .....\$123.95

**G. YAMAHA GENUINE WR PLASTIC KIT**

Yamaha has made it easy to put a fresh set of fenders, shrouds, and side covers on your bike. Just like the originals because they're Yamaha Genuine, they fit right the first time. Kit does not include graphics or Yamaha emblems.

Fits '07~'11 WR450F/WR250F

5UM-W003A-00-00 (Blue) .....\$129.99

**H. YAMAHA GENUINE REPLACEMENT SIDE COVERS**

The Yamaha Genuine Replacement Side Covers are sold as a set of two. Yamaha Genuine replacements for the stock covers (graphics not included). Less expensive than purchasing stock covers that use a very expensive inlay process for the graphics. Includes metal collars.

Fits '15~'17 WR250F

1SL-W003D-00-00 .....\$99.99

COVERS

HANDLEBARS & CONTROLS

PERFORMANCE

PROTECTION

SEATS

SPROCKETS & CHAINS

TRIM & ACCENTS

WHEELS

**COVERS**

**HANDLEBARS & CONTROLS**

**PERFORMANCE**

**PROTECTION**

**SEATS**

**SPROCKETS & CHAINS**

**TRIM & ACCENTS**

**WHEELS**

**A. YAMAHA SHORT SEAT**

Shorter than the stock seat (slightly under 1" shorter). Fully assembled seat assembly with gripper seat cover. Great for shorter riders. Helps hold rider in seated position. Simple installation and removal.

*Fits '16-'17 WR450F; '15-'17 WR250F*

**B11-F47C0-T0-00** ..... **\$139.99**

**B. YAMAHA TALL SEAT**

Taller than the stock seat (slightly under 1" taller). Fully assembled seat assembly with gripper seat cover. Great for taller riders. Helps hold rider in seated position. Simple installation and removal.

*Fits '16-'17 WR450F; '15-'17 WR250F*

**B11-F47C0-V0-00** ..... **\$139.99**

**C. GYTR® REAR SPROCKETS**

The GYTR Rear Sprockets are made from 7075-T6 billet aluminum CNC-machined for maximum fit accuracy. The rear sprockets features a radial mud groove etched just inside the sprocket teeth to shed mud and grit which saves weight and increases chain life. Sprocket sizes other than stock are for closed-course competition only on '06 and later off-road models and all street legal models. Changing the final drive ratio affects exhaust emissions and also affects speedometer readings.

*Fits '03-'17 WR450F; '15-'17 WR250F*

<b>GYT-75339-47-BK</b> (Black, 47T) .....	<b>\$61.95</b>
<b>GYT-75339-47-BL</b> (Blue, 47T) .....	<b>\$62.49</b>
<b>GYT-75339-48-BK</b> (Black, 48T) .....	<b>\$62.49</b>
<b>GYT-75339-48-BL</b> (Blue, 48T) .....	<b>\$62.49</b>
<b>GYT-75339-48-MG</b> (Gold, 48T) .....	<b>\$61.95</b>
<b>GYT-75339-49-BK</b> (Black, 49T) .....	<b>\$62.49</b>
<b>GYT-75339-49-BL</b> (Blue, 49T) .....	<b>\$62.49</b>
<b>GYT-75339-49-MG</b> (Gold, 49T) .....	<b>\$62.49</b>
<b>GYT-75339-50-BK</b> (Black, 50T) .....	<b>\$62.49</b>
<b>GYT-75339-50-BL</b> (Blue, 50T) .....	<b>\$62.49</b>
<b>GYT-75339-50-MG</b> (Gold, 50T) .....	<b>\$62.49</b>
<b>GYT-75339-51-BK</b> (Black, 51T) .....	<b>\$62.49</b>
<b>GYT-75339-51-BL</b> (Blue, 51T) .....	<b>\$62.49</b>
<b>GYT-75339-51-MG</b> (Gold, 51T) .....	<b>\$61.95</b>
<b>GYT-75339-52-BK</b> (Black, 52T) .....	<b>\$61.95</b>
<b>GYT-75339-52-BL</b> (Blue, 52T) .....	<b>\$62.49</b>
<b>GYT-75339-52-MG</b> (Gold, 52T) .....	<b>\$61.95</b>
<b>GYT-75339-53-BK</b> (Black, 53T) .....	<b>\$61.95</b>
<b>GYT-75339-53-BL</b> (Blue, 53T) .....	<b>\$61.95</b>

**D. GYTR® FRONT SPROCKETS BY TALON®**

GYTR Front Sprockets by Talon® are made from heat-treated chromoly steel and CNC-machined to extremely high tolerances. Zinc finish to help combat corrosion. Sprockets feature self-cleaning grooves to shed mud and grit, as well as reduce weight while maintaining strength. Sprocket sizes that increase the final drive ratio over stock are for closed-course competition only on '06 and later models because regulated exhaust emissions are affected.

*Fits '05-'17 WR450F*

<b>GYT-75439-13-00</b> (Silver, 13T) (Shown) .....	<b>\$26.49</b>
<b>GYT-75439-14-00</b> (Silver, 14T) .....	<b>\$26.49</b>

*Fits '15-'17 WR250F*

<b>GYT-75504-13-00</b> (Silver, 13T) .....	<b>\$26.49</b>
<b>GYT-75504-14-00</b> (Silver, 14T) .....	<b>\$26.49</b>

*Fits '05-'14 WR250F*

<b>GYT-75503-12-00</b> (Silver, 12T) .....	<b>\$26.49</b>
<b>GYT-75503-13-00</b> (Silver, 13T) .....	<b>\$26.49</b>
<b>GYT-75503-14-00</b> (Silver, 14T) .....	<b>\$26.49</b>



Shown here on YZ450F



Shown here on YZ450F

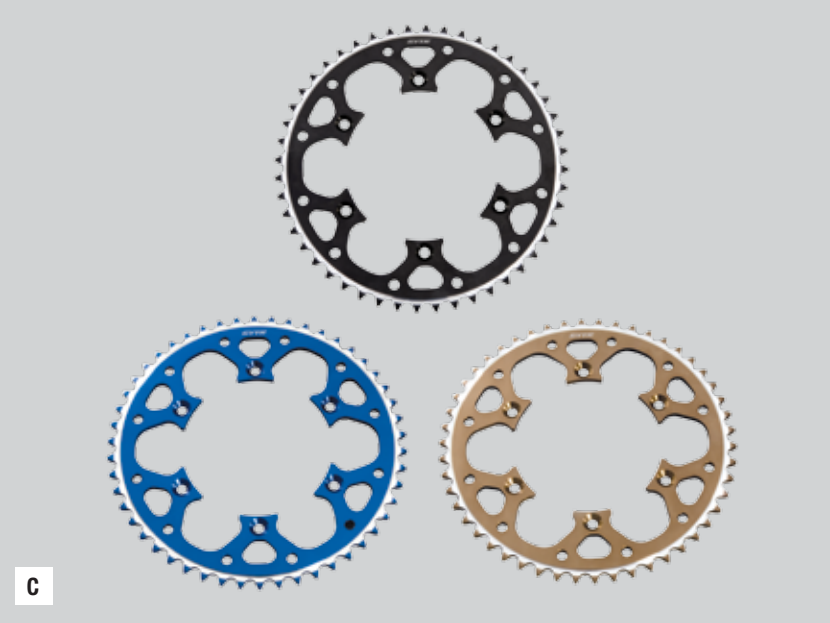





A



**A. GYTR® ULTRA-HIGH PERFORMANCE RACING CHAINS BY EK®**

GYTR Ultra-High Performance Racing Chains & Links by EK® offer the ultimate balance of performance and durability for various applications. Chains will not work on vehicles with a shaft drive.

**520 GDXL(2) Quadra-Ring Lite Chain:**

- Displacement Limit: Up to 650cc
- Tensile strength = 8,500 lb
- 120 links
- Designed to reduce friction up to 40%
- Last 50% longer than the conventional O-ring chains
- Lighter version of the 520 GDXL for small and mid-sized off-road motorcycles, sportbikes, and ATVs

GYT-ACC56-20-01 (Gold, 520 GDXL2 X-Ring Lite Chain).....	<b>\$102.95</b>
GYT-ACC56-20-20 (Gold, 520 GDXL2 Clip Type Master Link) ..	<b>\$4.95</b>
GYT-ACC56-20-02 (Gold, 520 GDXL2 Rivet Type Master Link) ..	<b>\$4.99</b>
GYT-ACC56-20-03 (Natural, 520 GDXL2 X-Ring Lite Chain).....	<b>\$109.49</b>
GYT-ACC56-20-04 (Natural, 520 GDXL2 Rivet Type Master Link) ..	<b>\$4.99</b>
GYT-ACC56-20-21 (Natural, 520 GDXL2 Clip Type Master Link).....	<b>\$4.99</b>

**520 GDO(2) O-Ring Chain:**

- Displacement Limit: Up to 650cc
- Tensile strength = 8,000 lb
- 120 links
- Manufactured by the inventor of the world's first O-ring
- Ideal for small and mid-sized off-road motorcycles, sportbikes, and ATVs
- Includes clip and rivet type master link

GYT-ACC56-20-05 (Gold, 520 GDO2 O-Ring Chain).....	<b>\$84.99</b>
GYT-ACC56-20-22 (Gold, 520 GDO2 Clip Type Master Link) ..	<b>\$5.99</b>
GYT-ACC56-20-06 (Gold, 520 GDO2 Rivet Type Master Link) ..	<b>\$3.49</b>
GYT-ACC56-20-07 (Natural, 520 GDO2 O-Ring Chain) .....	<b>\$74.99</b>
GYT-ACC56-20-23 (Natural, 520 GDO2 Clip Type Master Link) ..	<b>\$5.99</b>
GYT-ACC56-20-08 (Natural, 520 GDO2 Rivet Type Master Link) ..	<b>\$3.49</b>

**520 GMX2 Non-Sealed (Non O-Ring) Chain:**

- Displacement Limit: Up to 500cc
- Tensile strength = 8,400 lb
- 120 links
- Specifically designed for Motocross and Supercross
- Race-tested by Factory Riders to meet today's high performance machines
- High-tech CrH-coated pins for extremely hard outside surface and softer inside to increase the impact strength
- Includes clip and rivet type master link

GYT-ACC56-20-09 (Gold, 520 GMX2 Non O-Ring Chain) .....	<b>\$96.49</b>
GYT-ACC56-20-18 (Gold, 520 GMX2 Rivet Type Master Link) ..	<b>\$3.99</b>
GYT-ACC56-20-10 (Gold, 520 GMX2 Clip Type Master Link) ..	<b>\$2.99</b>
GYT-ACC56-20-11 (Natural, 520 GMX2 Non O-Ring Chain) ..	<b>\$87.49</b>
GYT-ACC56-20-17 (Natural, 520 GMX2 Rivet Type Master Link) ..	<b>\$3.99</b>
GYT-ACC56-20-12 (Natural, 520 GMX2 Clip Type Master Link) ..	<b>\$2.99</b>

**520 GMXL Non-Sealed (Non O-Ring) Chain Lite:**

- Displacement Limit: Up to 250cc
- Tensile strength = 6,600 lb
- 120 links
- Specifically designed for Motocross and Supercross
- Race-tested by Factory Riders to meet today's high performance machines
- Saves weight with less rotating mass
- High-tech CrH-coated pins for extremely hard outside surface and softer inside to increase the impact strength
- Includes clip and rivet type master link

GYT-OSS55-60-48 (Gold, 520 GMXL Non O-Ring Chain) .....	<b>\$101.49</b>
DBY-ACC56-34-45 (Gold, 520 GMXL Rivet Type Master Link) ..	<b>\$3.95</b>
GYT-OSS56-30-98 (Gold, 520 GMXL Clip Type Master Link) ..	<b>\$2.99</b>

COVERS

HANDLEBARS & CONTROLS

PERFORMANCE

PROTECTION

SEATS

SPROCKETS & CHAINS

TRIM & ACCENTS

WHEELS

COVERS

HANDLEBARS & CONTROLS

PERFORMANCE

PROTECTION

SPROCKETS & CHAINS

TRIM & ACCENTS

WHEELS

**A. OIL FILL CAP 20MM**

Anodized 6061 billet aluminum plug replaces stock plastic cap.

- Fits '06~'17 WR450F; '06~'17 WR250F*  
**5XC-E53A0-V0-00 (Black)** .....\$29.95
- Fits '06~'17 WR450F; '06~'17 WR250F*  
**GYT-2S235-01-00 (Blue)** .....\$30.99

**B. GYTR® MAGNETIC OIL DRAIN PLUG**

Replace the stock steel drain plug with this 6061 billet Magnetic Oil Drain Plug. 60% lighter than stock. Includes a magnet that collects metal shavings. Prevents metal shavings from circulating in the motor oil. Used by Yamaha Racing Teams.

- Fits '07~'16 WR250F; '07~'11 WR450F*  
**18P-E51C0-U0-00 (Red) (Shown)** .....\$32.99
- Fits '01~'02 WR426F; '98~'00 WR400F*  
**YZR-DRAIN-00-BL (Blue)**.....\$26.95

**C. GYTR® TIMING PLUG**

These anodized 6061 billet aluminum timing plugs replace the stock plastic plugs.

- Fits '16~'17 WR450F; '15~'17 WR250F*  
**33D-E51A0-T0-00 (Black) (36mm)** .....\$38.99
- Fits '16~'17 WR450F; '15~'17 WR250F*  
**33D-E51A0-V0-00 (Blue) (36mm)**.....\$38.99
- Fits '08~'11 WR450F; '08~'13 WR250F*  
**GYT-2S235-27-AL (Blue) (27mm)** .....\$28.95
- Fits '16~'17 WR450F; '15~'17 WR250F*  
**18P-E51B0-V0-00 (Red) (14mm)**.....\$30.95
- Fits '16~'17 WR450F; '15~'17 WR250F*  
**5XC-E51B0-V0-00 (Black) (14mm)**.....\$30.99
- Fits '16~'17 WR450F; '15~'17 WR250F*  
**GYT-2S235-14-AL (Blue) (14mm)** .....\$28.99

**D. GYTR® REAR BRAKE CLEVIS**

This billet rear brake clevis is machined to extremely tight tolerances which minimizes lateral movement or vibration of the rear brake pedal. This clevis allows for more height adjustment and features a titanium clevis pin that is half the weight of stock.

- Fits '09~'17 WR450F; '09~'17 WR250F*  
**5XC-F72A0-V0-00 (Blue)**.....\$50.99

**E. GYTR® BRAKE LINE PINCH**

The GYTR Brake Line Pinch replaces the stock steel pinch with a blue anodized billet aluminum piece.

- Fits '06~'17 WR450F; '06~'17 WR250F*  
**GYT-1P818-15-00 (Blue)** .....\$40.99



A



B



C



D



E



A

**A. YAMAHA KICKSTAND REMOVAL KIT (PEG MOUNT)**

Allows rider to remove the stock kickstand. Kit replaces the left side foot peg bracket. Kit includes the same components that come standard on YZ four-stroke models. The durability and quality you expect from Yamaha Genuine Parts.

*Fits '16~'17 WR450F; '15~'17 WR250F*  
**B91-F73A0-V0-00**.....\$25.99



B

**B. GYTR® BILLET OFFSET AXLE BLOCKS**

These billet aluminum soft anodized axle blocks are reversible and offset. They keep the adjustment bolts from extending too far back when running the rear wheel toward the back of the swingarm for maximum wheelbase.

*Fits '07~'17 WR450F; '15~'17 WR250F*  
**GYT-2S299-10-00 (Blue)**.....\$47.99



C

**C. YAMAHA GENUINE OFF-ROAD WHEEL ASSEMBLY\***

These complete original-equipment wheel assemblies are available for Yamaha WR models. Wheels are factory assembled, ready for installation, and come complete with hub assemblies, spoke sets, rim locks, wave-style brake rotors, and oil seals. Front and rear assemblies are sold separately.

*Fits '03~'17 WR450F; '03~'17 WR250F*  
**5TJ-W2519-J0-00 (Silver) (21" Front)**.....\$345.99  
**5TJ-W2539-G0-00 (Silver) (18" Rear)**.....\$535.99

**D. WHEEL SPACERS BY ZETA HIGH PERFORMANCE PRODUCTS**

Lightweight aluminum construction. Blue anodized. Enhanced styling. Installs in minutes.

*Fits '16~'17 WR450F; '15~'17 WR250F*  
**DBY-ACC56-34-67 (Front)**.....\$11.95  
**DBY-ACC56-34-68 (Rear)**.....\$11.95



D

**E. SUNLINE® RIM LOCK TOWER NUTS**

Machined from aircraft grade 6061-T6 aluminum. Closed nut design seals out mud and water, helping to prevent corrosion. Bevel washer design seats on the rim for a secure fit. Brilliant anodized finish.

*Fits all WR models*  
**GYT-OSS55-60-23 (Blue)**.....\$20.95



E

COVERS

HANDLEBARS & CONTROLS

PERFORMANCE

PROTECTION

SPROCKETS & CHAINS

TRIM & ACCENTS

WHEELS

\*Shown here with both Front and Rear Wheels

**COVERS**

**HANDLEBARS & CONTROLS**

**PERFORMANCE**

**PROTECTION**

**SPROCKETS & CHAINS**

**TRIM & ACCENTS**

**WHEELS**

**A. NEW! YZ MOTORCYCLE COVER**

Keep your YZ protected from dust at the track or in your garage with this Yamaha cover.

- Traditional Yamaha racing blue color featuring the GYTR, Yamalube and bLU cRU logos
- Lightweight material that can be quickly rolled up into the convenient attached storage bag
- Water resistant
- Equipped with a drawstring at the bottom to keep the cover in place

**NOTE:** Recommended for storage use only; not for trailering or transport

*Fits all YZ models except YZ85*

**1SL-F81A0-V0-00** (Blue) .....\$69.99



**A**

**B. GYTR® PIVOTING LEVERS BY ARC™**

These levers are designed with a folding-pivot blade that will fold in the event of a tip-over. Pivot ratio mimics stock for excellent performance.

*Fits '15~'17 YZ250; '16~'17 YZ250X*

**17D-H39B0-V0-00** (Clutch).....\$75.99

*Fits '01~'14 YZ250*

**GYT-5XC37-20-00** (Clutch) (Shown).....\$72.95



**B**



**C**

**C. SCOTT® MX2 GRIPS**

Designed for superior grip and comfort. Features underside waffle and soft-ridged upper patterns. Race proven. Grooved for safety wire. Sold in pairs.

*Fits '98~'17 YZ250; '17 YZ250X*

**ABA-YZRMX-GP-BK** (Black) .....\$9.99



**D**



**E**

**D. GYTR® 10" CROSSBAR PAD**

Designed for handlebars with crossbar. Printed on scratch resistant, 15 mil. vinyl featuring the Yamaha logo.

*Fits all Off-road models with crossbar-equipped handlebars*

**GYT-CROSS-BR-02** (Blue).....\$12.99

**E. GYTR® YAMAHA FACTORY RACING CLAMP COVER FOR 1-1/8" HANDLEBARS**

Printed on scratch-resistant 15-mil vinyl, featuring the Factory Racing logo. 10" long. For 1-1/8" Handlebars.

*For all Off-road Motorcycles with 1-1/8" Handlebars*

**GYT-5XC25-18-BL** (Blue).....\$21.99



**F**

**F. STEERING STABILIZER BY GPR®**

GPR® Stabilizers are precision-machined for proven reliability and superior quality. Kit comes with the GPRV1 stabilizer and billet-machined mounting brackets. The patented "pin-less" mounting brackets eliminates any slop that might normally exist with the traditional aftermarket pin-and-slot mounting systems. Easy installation provides bolt-on performance. No drilling, tapping, or welding required. Intended to fit with OEM bars.

*Fits '06~'17 YZ250; '16~'17 YZ250X*

**GYT-OSS56-31-87** .....\$486.49

**G. CYCRA® SERIES ONE PROBEND® HAND GUARDS**

Cycra® blended the best features of a straight bar and the classic Probend®, to result in the Series One Probend®. Many riders prefer the straight bar end with more of a closed-in area but still want ample room for levers, hands, and controls. Cycra® was able to accommodate both by adding a subtle drop in the bar end. Requires "U" Clamp Set (sold separately) for specific type of handlebar.

*Fits '05~'17 YZ250; '16~'17 YZ250X*

**DBY-ACC56-34-01** (Black).....\$64.95

**DBY-ACC56-34-02** (White) .....\$64.95

**DBY-ACC56-34-03** (Blue) .....\$65.49



**G**



A

**A. CYCRA® FACTORY PROBEND® CRM RACER PACK**

Exclusive Yamaha color way and shield graphics. Factory Edition Probend® CRM Complete Racer Pack includes: center reach bars, center reach mounting clamps, classic Enduro shields, Powergrip alloy bar ends, and all necessary hardware. Revolutionary patented billet construction. Trademarked Probend® shape. Replaceable integrated plastic abrasion guard; center reach clamps provide maximum bite to secure hand guards and allows for superior clearance on a wide range of bars. Powergrip alloy bar ends fit standard and oversized bars. Sold in pairs.

Fits '05~'17 YZ250; '16~'17 YZ250X

DBY-ACC56-34-69 (White) .....\$169.99  
DBY-ACC56-34-70 (Blue) .....\$169.99



B

**B. CYCRA® REBOUND HAND SHIELDS**

Unrivaled strength against trail debris. Vigorously tested for durability and quality assurance. Great alternative to wraparound systems for woods or MX. Patented folding shield for those unexpected obstacles or accidental falls. Billet aluminum mounts and reinforced backbone on shield. In-molded rubber edge provides increased protection. Can be mounted over or under bars for easy installation and clean hand control area. Includes shields, mounts, and hardware. Sold in pairs.

Fits '05~'17 YZ250; '16~'17 YZ250X

DBY-ACC56-34-71 (Black) .....\$79.99  
DBY-ACC56-34-72 (White) .....\$79.99  
DBY-ACC56-34-73 (Blue) .....\$79.99



C

**C. CYCRA® ALLOY STEALTH COMPLETE RACER PACK**

Complete Racer Pack includes shields, brackets, and hardware. Aircraft quality 6061 T-6 aluminum brackets. Slim, low-profile handshield design. Simple and easy to install. Rotating bolt plate allows brackets to be mounted above or below levers.

Fits '00~'17 YZ250; '16~'17 YZ250X

GYT-OSS56-30-59 (Black) .....\$51.95  
GYT-OSS56-30-60 (White) .....\$51.95  
GYT-OSS56-30-61 (Blue) .....\$51.95



D

**E. CYCRA® SERIES ONE PROBEND® BAR "U" CLAMP SET**

"U" Clamp Set for ProTaper® Pre-2007/Renthal® Fatbar®/Tag T2 Handlebars. To be used with DBY-ACC56-34-01, DBY-ACC56-34-02 or DBY-ACC56-34-03

Fits '05~'17 YZ250; '16~'17 YZ250X

DBY-ACC56-34-04 (Natural) .....\$36.49

"U" Clamp Set for 7/8" bars. To be used with DBY-ACC56-34-01, DBY-ACC56-34-02 or DBY-ACC56-34-03

Fits '05~'17 YZ250; '16~'17 YZ250X

DBY-ACC56-34-05 (Natural) .....\$44.95

"U" Clamp Set for ProTaper® Evo and Contour/Neken. To be used w/ DBY-ACC56-34-01, DBY-ACC56-34-02 or DBY-ACC56-34-03

Fits '05~'17 YZ250; '16~'17 YZ250X

DBY-ACC56-34-06 (Natural) .....\$44.95



E

COVERS

HANDLEBARS  
& CONTROLS

PERFORMANCE

PROTECTION

SPROCKETS  
& CHAINSTRIM &  
ACCENTS

WHEELS

COVERS

HANDLEBARS & CONTROLS

PERFORMANCE

PROTECTION

SPROCKETS & CHAINS

TRIM & ACCENTS

WHEELS

**A. ATHENA® 300CC BIG BORE KIT**

This 300cc Big Bore Kit by Athena® increases YZ250 displacement to 293cc. Cylinder is nickel-carbide plated with enlarged water passages for exceptional durability and performance. Bore increased to 72mm (stock is 66.4mm) stroke remains the same as stock (72mm). 15:1 compression ratio. Forged, domed piston. No case machining necessary. Kit includes cylinder, head, piston, rings, pin, clips, power valve assembly, and all required gaskets. YZ models are for closed-course competition regardless of modification.

*Fits '03~'17 YZ250; '16~'17 YZ250X*

- DBY-ACC56-34-48 (Big Bore Kit) .....\$1,294.99
- DBY-ACC56-34-49 (Replacement Piston - 71.95mm) .....\$198.99
- DBY-ACC56-34-50 (Replacement Piston - 71.96mm) .....\$198.99
- DBY-ACC56-34-51 (Replacement Ring Set) .....\$31.99
- DBY-ACC56-34-52 (Replacement Gasket Set) .....\$21.99

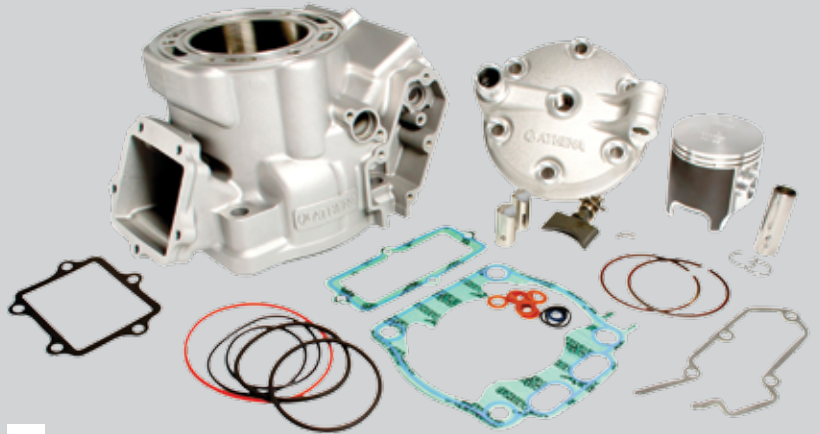

A

**B. YAMAHA GENUINE TOP END GASKET KIT**

These original-equipment Top End and Bottom End Gasket Kits were designed for convenience and total savings. Kits include the necessary gaskets, seals, and O-rings needed to reassemble your engine. They also include a complete part number list of all gaskets, seals, and O-rings for an in-depth engine overhaul.

*Fits '03~'16 YZ250; '16 YZ250X*

- 1P8-W0001-00-00 .....\$62.99



B

**C. GYTR® OFF-ROAD FLYWHEEL**

This complete flywheel assembly features an increase in inertia mass that smoothes the power delivery. Helps get power to the ground and keep your momentum up through corners and tricky sections, resulting in faster lap times and more race wins. Easy to install, allowing you the opportunity to change flywheels for different types of riding. Adds 8.04 oz for an inertia mass of 5.76 kg-cm². NOTE: Flywheels are measured by inertia weights because the affect of the weight differs depending on where it is in relation to the center of the crank. So a 4 oz. and 6 oz. weight might have the same affect depending on where they are positioned in relation to the center of the crank.

*Fits '03~'17 YZ250; '16~'17 YZ250X*

- GYT-5NX97-50-50 .....\$158.99



C

**D. VFORCE®3 HIGH PERF. REED VALVE SYSTEM**

The VForce® 3 High Performance Reed Valve System is ultra efficient and provides increased throttle response and acceleration. YZ models are for closed-course competition regardless of modification.

*Fits '05~'17 YZ250; '16~'17 YZ250X*

- DBY-ACC56-34-33 .....\$161.95



D



E

**E. GYTR® TWO-STAGE FOAM AIR FILTER**

High-flow, two-layer foam filter offers optimized filtration while maximizing airflow. Increases performance. Filter is completely washable and reusable. Service with Yamaha Genuine Foam Filter Oil. This accessory is restricted to closed-course use.

*Fits '05~'17 YZ250; '16~'17 YZ250X*

- GYT-4EW95-00-00 .....\$32.49



A



B



C



D



E



F



G

**A. PRE-FILTER BY OUTERWEARS®**

Offers less maintenance in dusty conditions and pre-filters dirt. No critical airflow restriction or power loss. Works with Yamaha OEM Air Filter or GYTR Air Filter.

Fits '98~'17 YZ250; '16~'17 YZ250X  
**GYT-OSS56-31-85** ..... \$22.49

**B. GYTR® BY FMF® RACING 2-STROKE EXHAUST PIPES**

GYTR by FMF® Racing 2-Stroke Exhaust Pipes features expansion chambers that are developed to maximize power gains throughout the rpm range and provide improved throttle response as well as a broader, smoother power band all providing a more tractable power delivery. Pipes feature the stamped GYTR by FMF® logo, hand-pounded seams, natural and unplanted carbon steel finish, materials and manufacturing techniques that make a true 'Race Spec' pipe. Includes O-rings and is lighter than stock. Designed to be used with the GYTR by FMF® Racing 2-Stroke Exhaust Silencer (sold separately). YZ models are for closed-course competition regardless of modification.

Fits '99~'17 YZ250; '16~'17 YZ250X  
**1P8-E46A0-T0-00 (Raw)** ..... \$255.99  
**1P8-E46A0-V0-00 (Nickel-Plated)** ..... \$255.99

**C. GYTR® BY FMF® GNARLY PIPE**

Focuses on increasing the lower rpm horsepower and torque. Nickel plated, 18-gauge steel construction. Features a "GYTR by FMF" embossed logo. Can get you in and out of the toughest off-road course environments. Built to withstand the harsh off-road competition conditions. YZ models are for closed-course competition regardless of modification.

Fits '09~'17 YZ250; '16~'17 YZ250X  
**BF1-E46A0-V0-00** ..... \$249.99

**D. GYTR® BY FMF® RACING 2-STROKE EXHAUST SILENCER**

The GYTR by FMF® Racing 2-Stroke Exhaust Silencer was designed to work with the GYTR Racing 2-Stroke Exhaust Pipes. Improves performance. Features button-head screws for easy maintenance. Lighter than stock. Features the GYTR by FMF® badge. YZ models are for closed-course competition regardless of modification.

Fits '09~'16 YZ250; '16~'17 YZ250X  
**1P8-E47A0-T0-00 (Aluminum)** ..... \$133.99

**E. GYTR® BY FMF® RACING 2-STROKE EXHAUST SILENCER**

The TurbineCore 2™ provides optimized performance with the functionality of a U.S. Forest-legal spark arrester for sanctioned off-road competition such as a Hare Hound series. The straight-through design of the spark arrester canister and the performance flow stainless steel end cap ensures strength, durability, and most importantly, track and trail competition-proven unrestricted power. YZ models are for closed-course competition regardless of modification.

Fits '99~'16 YZ250; '16~'17 YZ250X  
**1P8-E47A0-V0-00 (Stainless Steel)** ..... \$164.99

**F. YAMAHA REPLACEMENT 2-STROKE SILENCER PACKING KIT**

The Replacement Two-Stroke Muffler Packing is designed for repacking silencers with blown-out or oil-soaked packing.

Fits '09~'17 YZ250; '16~'17 YZ250X  
**YZR-5DHPA-CK-NG** ..... \$8.99

**G. OVERSIZED FUEL TANK BY IMS**

These tanks are designed to carry more fuel and enhance the appearance of your motorcycle. Larger capacity than stock, yet very slim and sleek. Provides greater riding distance per full tank. Perfect for the race track, or hare scrambles where the extra distance can mean the difference between winning and losing. These tanks are made with Polyethylene Crosslink for extra strength and durability. Suitable only for closed-course competition.

Fits '07~'17 YZ250; '16~'17 YZ250X  
**GYT-OSS56-31-66 (White)** ..... \$274.49

COVERS

HANDLEBARS & CONTROLS

PERFORMANCE

PROTECTION

SPROCKETS & CHAINS

TRIM & ACCENTS

WHEELS

COVERS

HANDLEBARS & CONTROLS

PERFORMANCE

PROTECTION

SPROCKETS & CHAINS

TRIM & ACCENTS

WHEELS

**A. GYTR® BILLET CLUTCH BASKET**

Precision-machined from the highest grade of aluminum and then anodized to achieve an exceptionally hard, wear-resistant surface. This clutch basket provides amazing, race-proven durability.

Fits '01~'17 YZ250; '16~'17 YZ250X

**GYT-5XF56-10-00** .....\$279.99

**B. GYTR® BILLET INNER CLUTCH HUB**

Precision-machined from the highest grade of aluminum, then hard anodized to achieve an exceptionally hard, wear-resistant surface for amazing race-proven durability. Additional oil passages help improve clutch performance and contribute to a 20% weight reduction and less rotational mass for improved acceleration.

Fits '01~'17 YZ250; '16~'17 YZ250X

**GYT-5XF56-40-00** .....\$565.95

**C. GYTR® BILLET PRESSURE PLATE**

Precision-machined from the highest grade of aluminum, then hard anodized to achieve an exceptionally hard, wear-resistant surface for amazing race-proven durability. Additional oil passages help improve clutch performance and also contribute to a 30% weight reduction and less rotational mass for improved acceleration.

Fits '05~'17 YZ250; '16~'17 YZ250X

**GYT-5XD56-20-00** .....\$169.99

**D. YAMAHA GENUINE OFF-ROAD CLUTCH KITS**

These complete Yamaha Clutch Kits include the plates, springs, and gaskets, ready to install. Refer to service manual for installation instructions.

Fits '03~'16 YZ250

**1P8-W001G-00-00** .....\$167.99

**E. GYTR® BILLET CLUTCH COVER**

Precision-machined from the highest grade of aluminum, then hard anodized to achieve an exceptionally hard, wear-resistant surface for amazing race-proven durability.

Fits '01~'17 YZ250; '16~'17 YZ250X

**GYT-5XF35-10-AL** .....\$148.99

**F. YAMAHA GENUINE FRONT FORK SEAL KIT**

These Yamaha Genuine Fork Seal Kits come with the original equipment fork and dust seals. Don't settle for the next best thing from the aftermarket use Yamaha Genuine Fork Seal Kits for longer life and less maintenance. Don't forget to order the proper fork oil for your bike, as well. Yamaha Fork Oils are formulated specifically for your model and deliver the highest suspension performance possible.

Fits '15~'17 YZ250; '17 YZ250X

**17D-W003B-00-00** .....\$67.99

Fits '99~'03 YZ250

**5ET-W003B-00-00** .....\$62.99

Fits '04~'14 YZ250

**1C3-W003B-00-00** .....\$67.99

**G. YAMAHA GENUINE BEARING KITS**

These Yamaha Genuine Shock Linkage Bearing Kits come with all of the components needed to rebuild the swingarm pivot, shock linkage, and shock bearings. Kits include all of the original equipment bearings, seals, O-rings, and collars your bike came with. Unlike some of the aftermarket companies that use a lower quality bearing, these bearings are O-ring-sealed to prevent intrusion of dirt, mud, and water and are made of top quality materials. So, if you don't want to do the job again and in half the time that your original bearings lasted, then use these Yamaha Genuine Kits.

Fits '09~'17 YZ250; '17 YZ250X

**1SR-W002E-00-00** (Shock Linkage Bearing Kit) .....\$89.99

Fits '05~'08 YZ250

**1P8-W002E-00-00** (Shock Linkage Bearing Kit) .....\$89.99

Fits '07~'17 YZ250; '16 YZ250X

**1SS-W002G-00-00** (Shock Bearing Kit) .....\$77.99

Fits '06~'16 YZ250; '16 YZ250X

**1HC-W002C-00-00** (Swingarm Pivot Bearing Kits) .....\$81.99

Fits '06 YZ250

**1C3-W002G-00-00** (Shock Bearing Kit) .....\$62.99



A



B



C



D



E



F



G





A

**A. GYTR® STAINLESS STEEL BRAIDED FRONT BRAKE LINE KIT**

These top-quality brake lines are designed to not fatigue even under extreme conditions.

*Fits '09~'17 YZ250; '16~'17 YZ250X*

**5XC-F58E0-V0-00**.....\$73.99

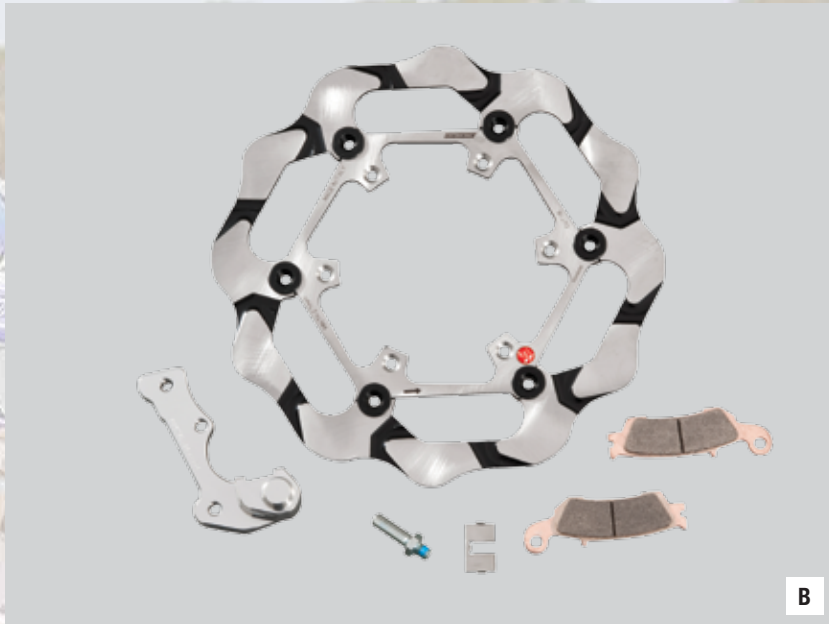

B

**B. BATFLY 270 OVERSIZED ROTOR KIT**

The 270mm Batfly is the natural evolution of the popular BRAKING™ design profile and is easily recognizable thanks to the black grooves that are cut across the outer braking track resembling bat wings, hence the name "Batfly." The new version features a new carrier that has been 100% heat treated and redesigned for strength as well as a redesign of the outer profile and grooves for a trick new look. With the larger 270mm diameter, maximum braking power is obtained, but with the Batfly design, brake feeling is increased even further, achieving the perfect combination of stopping power and brake feel. BRAKING™'s Batfly profile maintains the lowest temperature possible in race conditions, resulting in a better progression in brake feeling than any other oversized rotor kit available. Kit includes 270mm oversized Batfly design rotor, caliper relocation bracket, and a set of CM46 Sintered Race series pads.

*Fits '08~'17 YZ250; '16~'17 YZ250X*

**GYT-OSS56-30-63**.....\$354.95

**C. GYTR® BY BRAKING™ SOLID REAR BRAKE ROTOR**

The GYTR by BRAKING™ Solid Rear Brake Rotor is a high quality, durable, slot-less brake rotor that helps extend brake pad life in muddy conditions.

*Fits '06~'17 YZ250; '16~'17 YZ250X*

**1SL-F58G0-V0-00**.....\$107.99

**D. FORK BLEEDERS BY MOTION PRO®**

The Fork Bleeders by Motion Pro® features:

- Releases trapped air in forks with push of a button
- Small unobtrusive profile
- Installs in minutes
- Fits any bike with a 5mm x 0.08 thread pitch

*Fits '09~'17 YZ250; '16~'17 YZ250X*

**DBY-ACC56-34-66**.....\$15.99

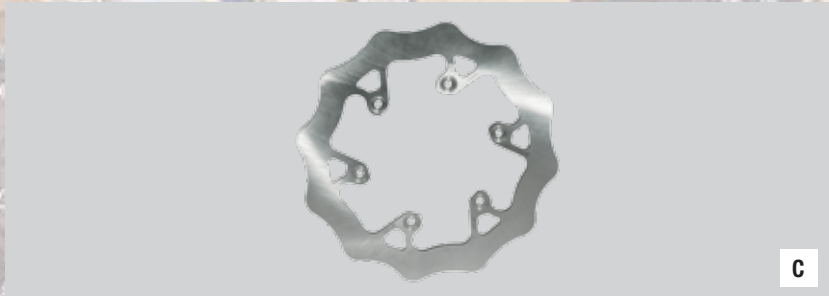

C

**E. CARBON FIBER RIGHT-HAND FORK LUG COVER BY LIGHTSPEED®**

This lightweight, functional cover protects the fork lug and rebound clicker while acting as a small glide plate to prevent "hang ups" in ruts.

*Fits '08~'17 YZ250*

**GYT-OSS56-32-54**.....\$72.95



D

**F. CARBON FIBER FRONT DISC GUARD BY LIGHTSPEED®**

Carbon fiber construction provides the ultimate combination of a lightweight yet super strong part. Directional venting aids heat reduction, reducing brake fade. Kevlar® reinforcement patch placed in strategic areas to aid in durability. Helps protect the front brake disc. Will work on oversized brake rotors up to 295mm.

*Fits '06~'17 YZ250; '16~'17 YZ250X*

**GYT-OSS56-30-29**.....\$108.49



E



F

- COVERS
- HANDLEBARS & CONTROLS
- PERFORMANCE
- PROTECTION
- SPROCKETS & CHAINS
- TRIM & ACCENTS
- WHEELS

**COVERS**

**HANDLEBARS & CONTROLS**

**PERFORMANCE**

**PROTECTION**

**SPROCKETS & CHAINS**

**TRIM & ACCENTS**

**WHEELS**

**A. GYTR® PLASTIC REAR BRAKE GUARD**

The GYTR Rear Brake Disc Guard is made of ultra-durable UHMWPE (Ultra High Molecular Weight Polyethylene). This disc guard is designed to flex and not bend upon impact. Improved durability in gnarly off-road conditions. Machined collars and OE style hardware allows for easy, same tool installation.

*Fits '06~'17 YZ250; '16~'17 YZ250X*  
**1DX-F58FO-V0-00**.....\$112.99

**B. CARBON FIBER REAR CALIPER GUARD & DISC GUARD SET BY LIGHTSPEED®**

This kit includes carbon fiber components that will help protect the rear brake disc and caliper. Sold as a set.

*Fits '06~'17 YZ250; '16~'17 YZ250X*  
**GYT-OSS56-30-28**.....\$97.95

**C. CARBON FIBER REAR CALIPER GUARD BY LIGHTSPEED®**

Durable, lightweight carbon fiber design helps protect your rear brake caliper.

*Fits '06~'17 YZ250; '16~'17 YZ250X*  
**GYT-OSS56-30-27**.....\$46.95

**D. GYTR® PLASTIC CHAIN GUIDE**

This ultra-durable UHMWPE plastic guide is designed to flex, not bend, in the event of impact.

*Fits '08~'13 YZ250; '16~'17 YZ250X*  
**17D-F21E0-V0-00 (Black)**.....\$88.99

**E. GYTR® SPROCKETS**

These GYTR Rear Sprockets are made from 7075-T6 billet aluminum CNC-machined for maximum fit accuracy. Features a radial mud groove etched just inside the sprocket teeth to shed mud and grit which saves weight and increases chain life. Sprocket sizes other than stock are for closed-course competition only on '06 and later off-road models and all street legal models. Changing the final drive ratio affects exhaust emissions and also affects speedometer readings.

*Front*  
*Fits '05~'17 YZ250; '16~'17 YZ250X*  
**GYT-75439-13-00 (Silver, 13T)**.....\$26.49  
**GYT-75439-14-00 (Silver, 14T)**.....\$26.49

*Rear*  
*Fits '99~'17 YZ250; '16~'17 YZ250X*  
**GYT-75339-47-BK (Black, 47T)**.....\$61.95  
**GYT-75339-47-BL (Blue, 47T)**.....\$62.49  
**GYT-75339-48-BK (Black, 48T)**.....\$62.49  
**GYT-75339-48-BL (Blue, 48T)**.....\$62.49  
**GYT-75339-48-MG (Gold, 48T)**.....\$61.95  
**GYT-75339-49-BK (Black, 49T)**.....\$62.49  
**GYT-75339-49-BL (Blue, 49T)**.....\$62.49  
**GYT-75339-49-MG (Gold, 49T)**.....\$62.49  
**GYT-75339-50-BK (Black, 50T)**.....\$62.49  
**GYT-75339-50-BL (Blue, 50T)**.....\$62.49  
**GYT-75339-50-MG (Gold, 50T)**.....\$62.49  
**GYT-75339-51-BK (Black, 51T)**.....\$62.49  
**GYT-75339-51-BL (Blue, 51T)**.....\$62.49  
**GYT-75339-51-MG (Gold, 51T)**.....\$61.95  
**GYT-75339-52-BK (Black, 52T)**.....\$61.95  
**GYT-75339-52-BL (Blue, 52T)**.....\$62.49  
**GYT-75339-52-MG (Gold, 52T)**.....\$61.95  
**GYT-75339-53-BK (Black, 53T)**.....\$61.95  
**GYT-75339-53-BL (Blue, 53T)**.....\$61.95



**A**



**B**



**C**



**D**

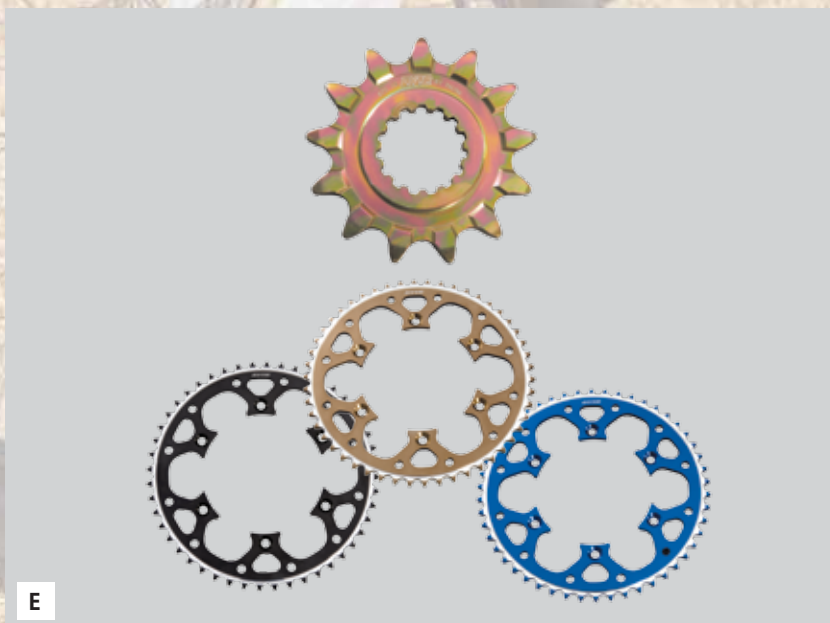

**E**



A



**A. GYTR® ULTRA-HIGH PERFORMANCE RACING CHAINS BY EK®**

GYTR Ultra-High Performance Racing Chains & Links by EK® offer the ultimate balance of performance and durability for various applications. Chains will not work on vehicles with a shaft drive.

**520 GDXL(2) Quadra-Ring Lite Chain:**

- Displacement Limit: Up to 650cc
- Tensile strength = 8,500 lb
- 120 links
- Designed to reduce friction up to 40%
- Lasts 50% longer than the conventional O-ring chains
- Lighter version of the 520 GDXL for small and mid-sized off-road motorcycles, sportbikes, and ATVs

GYT-ACC56-20-01 (Gold, 520 GDXL2 X-Ring Lite Chain).....	<b>\$102.95</b>
GYT-ACC56-20-20 (Gold, 520 GDXL2 Clip Type Master Link) ..	<b>\$4.95</b>
GYT-ACC56-20-02 (Gold, 520 GDXL2 Rivet Type Master Link) ..	<b>\$4.99</b>
GYT-ACC56-20-03 (Natural, 520 GDXL2 X-Ring Lite Chain) .....	<b>\$109.49</b>
GYT-ACC56-20-04 (Natural, 520 GDXL2 Rivet Type Master Link) .....	<b>\$4.99</b>
GYT-ACC56-20-21 (Natural, 520 GDXL2 Clip Type Master Link).....	<b>\$4.99</b>

**520 GDO(2) O-Ring Chain:**

- Displacement Limit: Up to 650cc
- Tensile strength = 8,000 lb
- 120 links
- Manufactured by the inventor of the world's first O-ring
- Ideal for small and mid-sized off-road motorcycles, sportbikes, and ATVs
- Includes clip and rivet type master link

GYT-ACC56-20-05 (Gold, 520 GDO2 O-Ring Chain).....	<b>\$84.99</b>
GYT-ACC56-20-22 (Gold, 520 GDO2 Clip Type Master Link) ..	<b>\$5.99</b>
GYT-ACC56-20-06 (Gold, 520 GDO2 Rivet Type Master Link) ..	<b>\$3.49</b>
GYT-ACC56-20-07 (Natural, 520 GDO2 O-Ring Chain) .....	<b>\$74.99</b>
GYT-ACC56-20-23 (Natural, 520 GDO2 Clip Type Master Link) .....	<b>\$5.99</b>
GYT-ACC56-20-08 (Natural, 520 GDO2 Rivet Type Master Link) .....	<b>\$3.49</b>

**520 GMX2 Non-Sealed (Non O-Ring) Chain:**

- Displacement Limit: Up to 500cc
- Tensile strength = 8,400 lb
- 120 links
- Specifically designed for Motocross and Supercross
- Race-tested by Factory Riders to meet today's high performance machines
- High-tech CrH-coated pins for extremely hard outside surface and softer inside to increase the impact strength
- Includes clip and rivet type master link

GYT-ACC56-20-09 (Gold, 520 GMX2 Non O-Ring Chain) .....	<b>\$96.49</b>
GYT-ACC56-20-18 (Gold, 520 GMX2 Rivet Type Master Link) ..	<b>\$3.99</b>
GYT-ACC56-20-10 (Gold, 520 GMX2 Clip Type Master Link) ..	<b>\$2.99</b>
GYT-ACC56-20-11 (Natural, 520 GMX2 Non O-Ring Chain) ..	<b>\$87.49</b>
GYT-ACC56-20-17 (Natural, 520 GMX2 Rivet Type Master Link) .....	<b>\$3.99</b>
GYT-ACC56-20-12 (Natural, 520 GMX2 Clip Type Master Link) .....	<b>\$2.99</b>

**520 GMXL Non-Sealed (Non O-Ring) Chain Lite:**

- Displacement Limit: Up to 250cc
- Tensile strength = 6,600 lb
- 120 links
- Specifically designed for Motocross and Supercross
- Race-tested by Factory Riders to meet today's high performance machines
- Saves weight with less rotating mass
- High-tech CrH-coated pins for extremely hard outside surface and softer inside to increase the impact strength
- Includes clip and rivet type master link

GYT-OSS55-60-48 (Gold, 520 GMXL Non O-Ring Chain).....	<b>\$101.49</b>
DBY-ACC56-34-45 (Gold, 520 GMXL Rivet Type Master Link) ..	<b>\$3.95</b>
GYT-OSS56-30-98 (Gold, 520 GMXL Clip Type Master Link) ..	<b>\$2.99</b>

COVERS

HANDLEBARS & CONTROLS

PERFORMANCE

PROTECTION

SPROCKETS & CHAINS

TRIM & ACCENTS

WHEELS

COVERS

HANDLEBARS & CONTROLS

PERFORMANCE

PROTECTION

SPROCKETS & CHAINS

TRIM & ACCENTS

WHEELS

**A. BLUE ANODIZED OIL DRAIN PLUG**

Replace the stock steel drain plug with this 6061 billet magnetic Oil Drain Plug. 60% lighter than stock. Includes a magnet that collects metal shavings, preventing them from circulating in the motor oil. Used by Yamaha Racing Teams.

*Fits '98~'17 YZ250; '16~'17 YZ250X*

**YZR-DRAIN-00-BL** (Blue).....\$26.95

**B. GYTR® BRAKE LINE PINCH**

This pinch replaces the stock steel pinch with a blue anodized billet aluminum piece.

*Fits '06~'17 YZ250; '16~'17 YZ250X*

**GYT-1P818-15-00** (Blue).....\$40.99

**C. GYTR® REAR BRAKE CLEVIS**

This billet rear brake clevis is machined to extremely tight tolerances which minimizes lateral movement or vibration of the rear brake pedal. This clevis allows for more height adjustment and features a titanium clevis pin that is half the weight of stock.

*Fits '09~'17 YZ250; '16~'17 YZ250X*

**5XC-F72A0-V0-00** (Blue).....\$50.99

**D. GYTR® BILLET OFFSET AXLE BLOCKS**

These billet aluminum soft anodized axle blocks are reversible and offset and keep the adjustment bolts from extending too far back when running the rear wheel toward the back of the swingarm for maximum wheelbase.

*Fits '07~'16 YZ250; '16~'17 YZ250X*

**GYT-2S299-10-00** (Blue).....\$47.99



A



B



C



D



A

**A. YZ WHEEL KITS\***

These complete original-equipment wheel assemblies are available for Yamaha YZ models. Wheels are factory assembled, ready for installation, and come complete with hub assemblies, spoke sets, rim locks, wave-style brake rotors, and oil seals.

*Fits '09~'17 YZ250*

- 5XC-W2519-LO-00 (Silver) (21" Front) .....\$345.99
- 5XC-W2539-LO-00 (Silver) (19" Rear).....\$535.99

**B. GYTR® BILLET WHEEL SPACER KIT**

Get Yamaha Racing Team looks and function with these billet wheel spacers that have integrated dust covers and a seal lip that helps keep the spacers in place during wheel installation/ removal.

*Fits '07~'17 YZ250*

- 5XC-F51A0-V0-00 (Blue) (Front) .....\$40.99

**C. WHEEL SPACERS BY ZETA HIGH PERFORMANCE PRODUCTS**

The 22mm front and 22mm rear Wheel Spacers by ZETA High Performance Products features: Lightweight aluminum construction, and blue-anodized enhanced styling. Installs in minutes.

*Fits '06~'17 YZ250; '16~'17 YZ250X*

- DBY-ACC56-34-68 (Blue) (Rear) .....\$11.95

**D. SUNLINE® RIM LOCK TOWER NUTS**

Machined from aircraft grade 6061-T6 aluminum. Closed nut design seals out mud and water, helping to prevent corrosion. Bevel washer design seats on the rim for a secure fit. Brilliant anodized finish.

*Fits all YZ & WR models*

- GYT-OSS55-60-23 (Blue) .....\$20.95

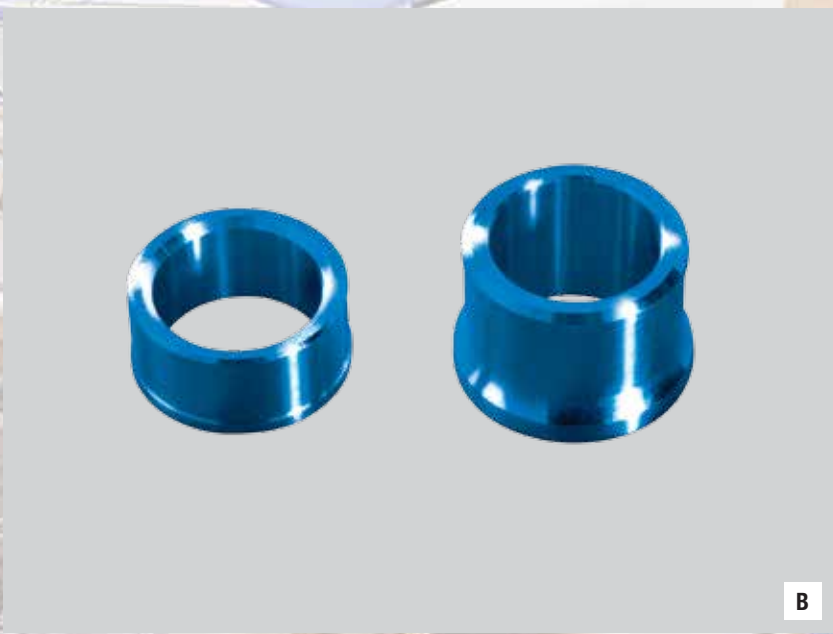

B

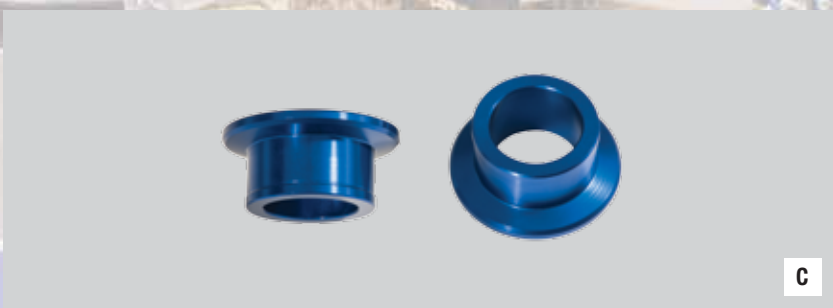

C



D

COVERS

HANDLEBARS & CONTROLS

PERFORMANCE

PROTECTION

SPROCKETS & CHAINS

TRIM & ACCENTS

WHEELS

\*Shown here with both Front and Rear Wheels

COVERS

HANDLEBARS & CONTROLS

PERFORMANCE

PROTECTION

SEATS

SPROCKETS & CHAINS

TRIM & ACCENTS

WHEELS

**A. NEW! YZ MOTORCYCLE COVER**

Keep your YZ protected from dust at the track or in your garage with this Yamaha cover.

- Traditional Yamaha racing blue color featuring the GYTR, Yamalube and bLU cRU logos
- Lightweight material that can be quickly rolled up into the convenient attached storage bag
- Water resistant
- Equipped with a drawstring at the bottom to keep the cover in place

**NOTE:** Recommended for storage use only; not for trailering or transport

Fits all YZ models except YZ85

1S1-F81A0-V0-00 (Blue) .....\$69.99



A

**B. GYTR® PIVOTING LEVERS BY ARC™**

These levers are designed with a folding-pivot blade that will fold in the event of a tip-over. Pivot ratio mimics stock for excellent performance.

Fits '15~'17 YZ125

17D-H39B0-V0-00 (Clutch).....\$72.95

Fits '01~'14 YZ125

GYT-5XC37-20-00 (Clutch) (Shown).....\$75.99

Fits '05~'17 YZ125

GYT-5XC37-30-00 (Black) (Brake) .....\$75.99



B

**C. SCOTT® MX2 GRIPS**

Designed for superior grip and comfort. Features underside waffle and soft-ridged upper patterns. Race proven. Grooved for safety wire. Sold in pairs.

Fits '98~'17 YZ125

ABA-YZRMX-GP-BK (Black) (Shown).....\$9.99



C

**D. GYTR® 10" CROSSBAR PAD**

Designed for handlebars with crossbar. Printed on scratch resistant, 15 mil. vinyl featuring the Yamaha logo.

Fits all Off-road models with crossbar-equipped handlebars

GYT-CROSS-BR-02 (Blue).....\$12.99



D

E

**E. GYTR® YAMAHA FACTORY RACING CLAMP COVER FOR 1-1/8" HANDLEBARS**

Printed on scratch-resistant 15-mil vinyl, featuring the Factory Racing logo. 10" long. For 1-1/8" Handlebars.

For all Off-road Motorcycles with 1-1/8" Handlebars

GYT-5XC25-18-BL (Blue).....\$21.99

**F. CYCRA® FACTORY PROBEND® CRM RACER PACK**

Exclusive Yamaha color way and shield graphics Factory Edition Probend® CRM Complete Racer Pack includes:

- Center reach bars
- Center reach mounting clamps
- Classic Enduro shields
- Powergrip alloy bar ends and all necessary hardware
- Revolutionary patented billet construction
- Trademarked ProBend® shape
- Replaceable integrated plastic abrasion guard; center reach clamps provide maximum bite to secure hand guards and allows for superior clearance on a wide range of bars
- Powergrip alloy bar ends fit standard and oversized bars
- Sold in pairs

Fits '05~'17 YZ125

DBY-ACC56-34-69 (White) .....\$169.99

DBY-ACC56-34-70 (Blue) .....\$169.99



F



A

**A. CYCRA® REBOUND HAND SHIELDS**

- Unrivaled strength against trail debris
- Vigorously tested for durability and quality assurance
- Great alternative to wraparound systems for woods or MX
- Patented folding shield for those unexpected obstacles or accidental falls
- Billet aluminum mounts and reinforced backbone on shield
- In-molded rubber edge provides increased protection
- Can be mounted over or under bars for easy installation and clean hand control area
- Includes shields, mounts, and hardware
- Sold in pairs

Fits '05~'17 YZ125

DBY-ACC56-34-71 (Black)	\$79.99
DBY-ACC56-34-72 (White)	\$79.99
DBY-ACC56-34-73 (Blue)	\$79.99



B

**B. CYCRA® SERIES ONE PROBEND® HAND GUARDS**

Cycra® blended the best features of a straight bar and the classic Probend®, to result in the Series One Probend®. Many riders prefer the straight bar end with more of a closed-in area but still want ample room for levers, hands, and controls. Cycra® was able to accommodate both by adding a subtle drop in the bar end. Requires "U" Clamp Set (sold separately) for specific type of handlebar.

Fits '05~'17 YZ125

DBY-ACC56-34-01 (Black)	\$64.95
DBY-ACC56-34-02 (White)	\$64.95
DBY-ACC56-34-03 (Blue)	\$65.49



C

**C. CYCRA® ALLOY STEALTH COMPLETE RACER PACK**

Complete Racer Pack includes shields, brackets, and hardware. Aircraft quality 6061 T-6 aluminum brackets. Slim, low-profile handshield design. Simple and easy to install. Rotating bolt plate allows brackets to be mounted above or below levers.

Fits '00~'17 YZ125

GYT-OSS56-30-59 (Black)	\$51.95
GYT-OSS56-30-60 (White)	\$51.95
GYT-OSS56-30-61 (Blue)	\$51.95



D

**D. CYCRA® CENTER REACH MOUNT COMPLETE RACER PACK**

These Center Reach Mount (CRM) Complete Racer Packs include CRM Probend® bars, CRM mount clamps, classic Enduro™ shields, Powergrip bar ends, and Probend® abrasion guards. Revolutionary patent-pending design. Trademark Probend® shape. Replaceable integrated plastic abrasion guard. Center-reach clamps provide maximum bite to secure hand guards and allow for superior clearance on a wide range of bars. Powergrip alloy bar ends fit 1-1/8" oversized bars. Some control adjustments may be necessary.

Fits '00~'17 YZ125

GYT-OSS56-30-48 (White)	\$132.95
GYT-OSS56-30-49 (Blue)	\$132.95

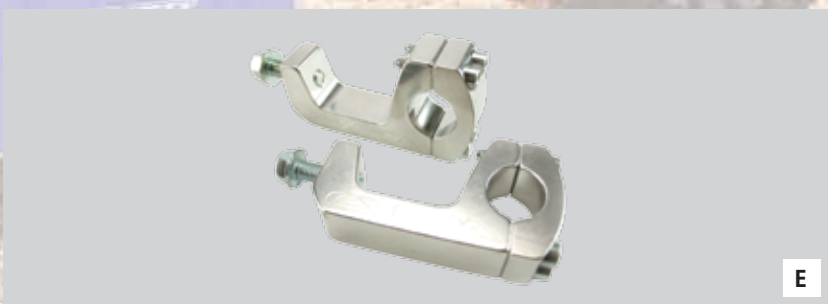

E

**E. CYCRA® SERIES ONE PROBEND® BAR "U" CLAMP SET**

U Clamp Set for ProTaper® Pre-2007/Renthal® Fatbar®/Tag T2 Handlebars. To be used with DBY-ACC56-34-01, DBY-ACC56-34-02 or DBY-ACC56-34-03

Fits '05~'17 YZ125

DBY-ACC56-34-04 (Natural)	\$36.49
---------------------------	---------

U Clamp set for 7/8" bars.

To be used with DBY-ACC56-34-01, DBY-ACC56-34-02 or DBY-ACC56-34-03

Fits '05~'17 YZ125

DBY-ACC56-34-05 (Natural)	\$44.95
---------------------------	---------

U Clamp set for 7/8" bars.

To be used with DBY-ACC56-34-01, DBY-ACC56-34-02 or DBY-ACC56-34-03

Fits '05~'17 YZ125

DBY-ACC56-34-06 (Natural)	\$44.95
---------------------------	---------

COVERS

HANDLEBARS  
& CONTROLS

PERFORMANCE

PROTECTION

SEATS

SPROCKETS  
& CHAINSTRIM &  
ACCENTS

WHEELS

COVERS

HANDLEBARS & CONTROLS

PERFORMANCE

PROTECTION

SEATS

SPROCKETS & CHAINS

TRIM & ACCENTS

WHEELS

**A. ATHENA® 144CC BIG BORE KIT**

Big Bore Cylinder Kit includes brand new nickel-carbide plated cylinder with enlarged water passages, precision made piston with rings, pins, clips, gaskets, O-rings, and all other parts needed for a complete installation. Machining of cases is required. YZ models are for closed-course competition regardless of modification.

*Fits '05~'17 YZ125*

GYT-OSS56-30-99 (Big Bore Kit).....	\$842.95
GYT-OSS56-31-00 (Piston Kit A).....	\$209.95
GYT-OSS56-31-01 (Piston Kit B).....	\$209.95
GYT-OSS56-31-02 (Gasket Kit).....	\$56.95
GYT-OSS56-31-03 (Ring Set).....	\$12.49
GYT-OSS56-31-04 (Power Valves - Both).....	\$199.95
GYT-OSS56-31-05 (Cylinder head).....	\$141.49



A

**B. YAMAHA GENUINE TOP END GASKET KITS**

These original-equipment Top End and Bottom End Gasket Kits were designed for convenience and total savings. Kits include the necessary gaskets, seals, and O-rings needed to reassemble your engine. They also include a complete part number list of all gaskets, seals, and O-rings for an in-depth engine overhaul.

*Fits '06~'17 YZ125*

1C3-W0001-00-00.....	\$47.99
----------------------	---------

**C. VFORCE®3 HIGH PERFORMANCE REED VALVE SYSTEM**

The VForce® 3 High Performance Reed Valve System is ultra efficient and provides increased throttle response and acceleration. YZ models are for closed-course competition regardless of modification.

*Fits '05~'17 YZ125*

DBY-ACC56-34-31.....	\$159.95
----------------------	----------



B

**D. GYTR® TWO-STAGE FOAM AIR FILTER**

High-flow, two-layer foam filter offers optimized filtration while maximizing airflow. Increases performance. Filter is completely washable and reusable. Service with Yamaha Genuine Foam Filter Oil. This accessory is restricted to closed-course use.

*Fits '05~'17 YZ125*

GYT-4EW95-00-00.....	\$32.49
----------------------	---------



C

**E. PRE-FILTER BY OUTERWEARS®**

Offers less maintenance in dusty conditions and pre-filters dirt. No critical airflow restriction or power loss. Works with Yamaha OEM Air Filter or GYTR Air Filter.

*Fits '05~'17 YZ125*

GYT-OSS56-31-85.....	\$22.49
----------------------	---------



D

E





Raw

Nickel-Plated

A

**A. GYTR® BY FMF® RACING 2-STROKE EXHAUST PIPES**

GYTR by FMF® Racing 2-Stroke Exhaust Pipes features expansion chambers that are developed to maximize power gains throughout the rpm range and provide improved throttle response as well as a broader, smoother power band all providing a more tractable power delivery. Pipes feature the stamped GYTR by FMF® logo, hand-pounded seams, natural and unplanted carbon steel finish, materials and manufacturing techniques that make a true 'Race Spec' pipe. Includes O-rings and is lighter than stock. Designed to be used with the GYTR by FMF® Racing 2-Stroke Exhaust Silencer (sold separately). YZ models are for closed-course competition regardless of modification.

Fits '06-'17 YZ125

<b>1C3-E46A0-T0-00</b> (Raw) .....	<b>\$239.99</b>
<b>1C3-E46A0-V0-00</b> (Nickel-Plated) .....	<b>\$245.99</b>

**B. GYTR® BY FMF® RACING 2-STROKE EXHAUST SILENCER**

The GYTR by FMF® Racing 2-Stroke Exhaust Silencer was designed to work with the GYTR Racing 2-Stroke Exhaust Pipes. Improves performance. Features button-head screws for easy maintenance. Lighter than stock. Features the GYTR by FMF® badge. YZ models are for closed-course competition regardless of modification.

Fits '06-'17 YZ125

<b>1C3-E47A0-T0-00</b> (Aluminum) .....	<b>\$139.99</b>
---	-----------------



B

**C. YAMAHA REPLACEMENT 2-STROKE SILENCER PACKING KIT**

The Replacement Two-Stroke Muffler Packing is designed for repacking silencers with blown-out or oil-soaked packing.

Fits '90-'17 YZ125

<b>YZR-5DHPA-CK-NG</b> .....	<b>\$8.99</b>
------------------------------	---------------



C



D

**D. GYTR® BILLET CLUTCH COVER**

GYTR Clutch Components are precision machined from aerospace-quality aluminum alloys with a unique hard coating. This provides superior performance and clutch feel, as well as excellent component durability. The patent-pending "auto oiling system" forces oil through specially cut holes in the pressure plate, into the inner hub, and then to the clutch plates. This results improved clutch performance, with lower clutch temperatures, less clutch expansion and extended clutch life.

Fits '05-'17 YZ125

<b>GYT-1C335-10-AL</b> .....	<b>\$143.95</b>
------------------------------	-----------------

**E. GYTR® BILLET CLUTCH PRESSURE PLATE**

Precision-machined from the highest grade of aluminum, then hard anodized to achieve an exceptionally hard, wear-resistant surface for amazing race-proven durability. Additional oil passages help improve clutch performance and also contribute to a 30% weight reduction and less rotational mass for improved acceleration.

Fits '00-'17 YZ125

<b>GYT-5XC56-20-00</b> .....	<b>\$166.95</b>
------------------------------	-----------------



E

**F. GYTR® BILLET INNER CLUTCH HUB**

Precision machined from the highest grade of aluminum, then hard anodized to achieve an exceptionally hard, wear-resistant surface for amazing race-proven durability. Additional oil passages help improve clutch performance and contribute to a 20% weight reduction and less rotational mass for improved acceleration.

Fits '93-'17 YZ125

<b>GYT-5XE56-40-00</b> .....	<b>\$290.95</b>
------------------------------	-----------------



F

COVERS

HANDLEBARS & CONTROLS

PERFORMANCE

PROTECTION

SEATS

SPROCKETS & CHAINS

TRIM & ACCENTS

WHEELS

**COVERS**

**HANDLEBARS & CONTROLS**

**PERFORMANCE**

**PROTECTION**

**SEATS**

**SPROCKETS & CHAINS**

**TRIM & ACCENTS**

**WHEELS**

**A. YAMAHA GENUINE OFF-ROAD CLUTCH KITS**

These complete Yamaha Clutch Kits include the plates, springs, and gaskets, ready to install. Refer to service manual for installation instructions.

*Fits '06~'16 YZ125*  
**1C3-W001G-00-00** ..... **\$167.99**

**B. OVERSIZED FUEL TANK BY IMS**

These tanks are designed to carry more fuel and enhance the appearance of your motorcycle. Larger capacity than stock, yet very slim and sleek. Provides greater riding distance per full tank. Perfect for the race track or hare scrambles where the extra distance can mean the difference between winning and losing. These tanks are made with Polyethylene Crosslink for extra strength and durability. Suitable only for closed-course competition.

*Fits '07~'17 YZ125 (3.2 gal. capacity)*  
**GYT-OSS56-31-66 (White)** ..... **\$274.49**

**C. YAMAHA GENUINE FRONT FORK SEAL KITS**

These Yamaha Genuine Fork Seal Kits come with the original equipment fork and dust seals. Don't settle for the next best thing from the aftermarket use Yamaha Genuine Fork Seal Kits for longer life and less maintenance. Don't forget to order the proper fork oil for your bike, as well. Yamaha Fork Oils are formulated specifically for your model and deliver the highest suspension performance possible.

*Fits '15~'16 YZ125*  
**17D-W003B-00-00** ..... **\$67.99**

*Fits '04~'14 YZ125*  
**1C3-W003B-00-00** ..... **\$67.99**

*Fits '99~'03 YZ125*  
**5ET-W003B-00-00** ..... **\$62.99**

**D. YAMAHA GENUINE BEARING KITS**

These Yamaha Genuine Bearing Kits come with all of the components needed to rebuild the swingarm pivot, shock linkage, and shock bearings. Kits include all of the original equipment bearings, seals, O-rings, and collars your bike came with. Unlike some of the aftermarket companies that use a lower quality bearing, these bearings are O-ring sealed to prevent intrusion of dirt, mud, and water and are made of top quality materials. If you don't want to do the job again and in half the time your original bearings lasted, use these Yamaha Genuine kits.

*Fits '07~'16 YZ125*  
**1SS-W002G-00-00 (Shock Bearing Kit) (Shown)** ..... **\$77.99**

*Fits '06 YZ125*  
**1C3-W002G-00-00 (Shock Bearing Kit)** ..... **\$62.99**

*Fits '09~'16 YZ125*  
**1SR-W002E-00-00 (Shock Linkage Bearing Kit)** ..... **\$89.99**

*Fits '05~'08 YZ125*  
**1P8-W002E-00-00 (Shock Linkage Bearing Kit)** ..... **\$89.99**

*Fits '06~'16 YZ125*  
**1C3-W002C-00-00 (Swingarm Pivot Bearing Kit)** ..... **\$81.99**

**E. FORK BLEEDERS BY MOTION PRO®**

The Fork Bleeders by Motion Pro® features:

- Releases trapped air in forks with push of a button
- Small unobtrusive profile
- Installs in minutes
- Fits any bike with a 5mm x 0.08 thread pitch

*Fits '09~'17 YZ125*  
**DBY-ACC56-34-66** ..... **\$15.99**



**A**



**B**



**C**



**D**



**E**



A

**A. GYTR® STAINLESS STEEL BRAIDED FRONT BRAKE LINE KIT**

These top-quality brake lines are designed to not fatigue even under extreme conditions.

*Fits '09~'17 YZ125*  
**5XC-F58E0-V0-00**.....\$73.99



B

**B. BATFLY 270 OVERSIZED ROTOR KIT**

The 270mm Batfly is the natural evolution of the popular BRAKING™ design profile and is easily recognizable thanks to the black grooves that are cut across the outer braking track resembling bat wings, hence the name "Batfly." The new version features a new carrier that has been 100% heat treated and redesigned for strength as well as a redesign of the outer profile and grooves for a trick new look. With the larger 270mm diameter, maximum braking power is obtained, but with the Batfly design, brake feeling is increased even further, achieving the perfect combination of stopping power and brake feel. BRAKING™'s Batfly profile maintains the lowest temperature possible in race conditions, resulting in a better progression in brake feeling than any other oversized rotor kit available. Kit includes 270mm oversized Batfly design rotor, caliper relocation bracket, and a set of CM46 Sintered Race series pads.

*Fits '08~'17 YZ125*  
**GYT-OSS56-30-63**.....\$354.95

**C. GYTR® BY BRAKING™ SOLID REAR BRAKE ROTOR**

The GYTR by BRAKING™ Solid Rear Brake Rotor is a high quality, durable, slot-less brake rotor that helps extend brake pad life in muddy conditions.

*Fits '06~'17 YZ250; '16~'17 YZ250X*  
**1SL-F58G0-V0-00**.....\$107.99

**D. CARBON FIBER FRONT DISC GUARD BY LIGHTSPEED®**

Carbon fiber construction provides the ultimate combination of a lightweight yet super strong part. Directional venting aids heat reduction, reducing brake fade. Kevlar® reinforcement patch placed in strategic areas to aid in durability. Helps protect the front brake disc. Will work on oversized brake rotors up to 295mm.

*Fits '06~'17 YZ125*  
**GYT-OSS56-30-29**.....\$108.49



C



D

**E. CARBON FIBER RIGHT-HAND FORK LUG COVER BY LIGHTSPEED®**

This lightweight, functional cover protects the fork lug and rebound clicker while acting as a small glide plate to prevent "hang ups" in ruts.

*Fits '08~'17 YZ125*  
**GYT-OSS56-32-54**.....\$72.95



E

**F. CARBON FIBER REAR CALIPER GUARD BY LIGHTSPEED®**

Durable, lightweight carbon fiber design helps protect your rear brake caliper.

*Fits '06~'17 YZ125*  
**GYT-OSS56-30-27**.....\$46.95

**G. GYTR® PLASTIC REAR BRAKE GUARD**

The GYTR Rear Brake Disc Guard is made of ultra-durable UHMWPE (Ultra High Molecular Weight Polyethylene). This disc guard is designed to flex and not bend upon impact. Improved durability in gnarly off-road conditions. Machined collars and OE style hardware allows for easy, same tool installation.

*Fits '06~'17 YZ125*  
**1DX-F58F0-V0-00**.....\$112.99



F



G

COVERS

HANDLEBARS & CONTROLS

PERFORMANCE

PROTECTION

SEATS

SPROCKETS & CHAINS

TRIM & ACCENTS

WHEELS

COVERS

HANDLEBARS & CONTROLS

PERFORMANCE

PROTECTION

SEATS

SPROCKETS & CHAINS

TRIM & ACCENTS

WHEELS

**A. CARBON FIBER REAR CALIPER GUARD & DISC GUARD SET BY LIGHTSPEED®**

This kit includes carbon fiber components that will help protect the rear brake disc and caliper. Sold as a set.

Fits '06~'17 YZ125

**GYT-OSS56-30-28**.....\$97.95



A

**B. GYTR® PLASTIC CHAIN GUIDE**

This ultra-durable UHMWPE plastic guide is designed to flex, not bend, in the event of impact.

Fits '08~'17 YZ125

**17D-F21E0-V0-00** (Black).....\$88.99



B

**C GYTR® GRIPPER SEAT COVER**

The GYTR Gripper Seat Cover is designed to provide maximum grip when hitting the dirt. Features the GYTR logo.

Fits '02~'17 YZ125

**GYT-1P824-40-00** (Blue/Black).....\$49.95



C

**D. GYTR® REAR SPROCKETS**

These GYTR Rear Sprockets are made from 7075-T6 billet aluminum CNC-machined for maximum fit accuracy. Features a radial mud groove etched just inside the sprocket teeth to shed mud and grit which saves weight and increases chain life. Sprocket sizes other than stock are for closed-course competition only on '06 and later off-road models and all street legal models. Changing the final drive ratio affects exhaust emissions and also affects speedometer readings.

Fits '99~'17 YZ125

- GYT-75339-47-BK** (Black, 47T) .....\$61.95
- GYT-75339-47-BL** (Blue, 47T) .....\$62.49
- GYT-75339-48-BK** (Black, 48T) .....\$62.49
- GYT-75339-48-BL** (Blue, 48T) .....\$62.49
- GYT-75339-48-MG** (Gold, 48T) .....\$61.95
- GYT-75339-49-BK** (Black, 49T) .....\$62.49
- GYT-75339-49-BL** (Blue, 49T) .....\$62.49
- GYT-75339-49-MG** (Gold, 49T) .....\$62.49
- GYT-75339-50-BK** (Black, 50T) .....\$62.49
- GYT-75339-50-BL** (Blue, 50T) .....\$62.49
- GYT-75339-50-MG** (Gold, 50T) .....\$62.49
- GYT-75339-51-BK** (Black, 51T) .....\$62.49
- GYT-75339-51-BL** (Blue, 51T) .....\$62.49
- GYT-75339-51-MG** (Gold, 51T) .....\$61.95
- GYT-75339-52-BK** (Black, 52T) .....\$61.95
- GYT-75339-52-BL** (Blue, 52T) .....\$62.49
- GYT-75339-52-MG** (Gold, 52T) .....\$61.95
- GYT-75339-53-BK** (Black, 53T) .....\$61.95
- GYT-75339-53-BL** (Blue, 53T) .....\$61.95

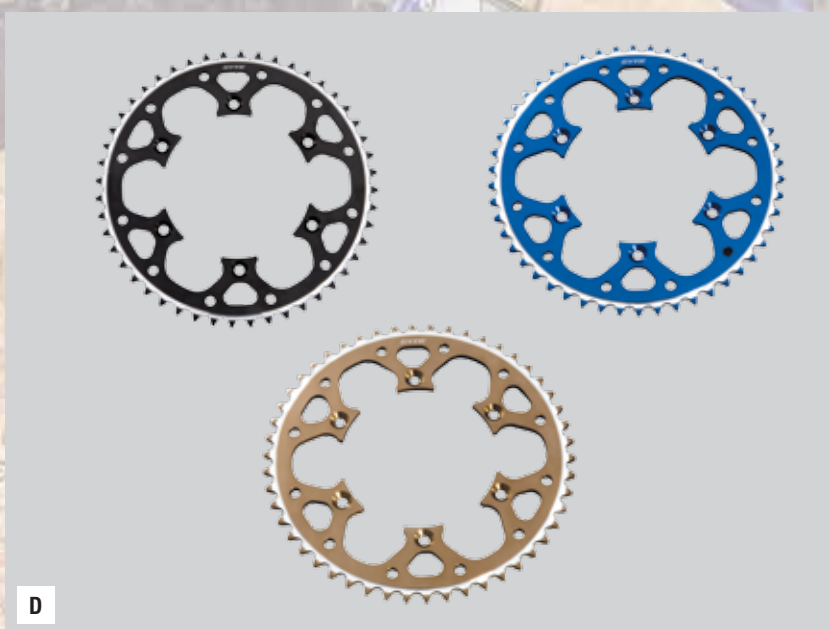

D

**E. GYTR® FRONT SPROCKETS BY TALON®**

Made from heat-treated chromoly steel and CNC-machined to extremely high tolerances. Zinc finish to help combat corrosion. Sprockets feature self-cleaning grooves to shed mud and grit, as well as reduce weight while maintaining strength. Sprocket sizes that increase the final drive ratio over stock are for closed-course competition only on '06 and later models because regulated exhaust emissions are affected.

Fits '06~'17 YZ125

- GYT-75503-12-00** (Silver, 12T) .....\$26.49
- GYT-75503-13-00** (Silver, 13T) .....\$26.49
- GYT-75503-14-00** (Silver, 14T) .....\$26.49



E



A



**A. GYTR® ULTRA-HIGH PERFORMANCE RACING CHAINS BY EK®**

GYTR Ultra-High Performance Racing Chains & Links by EK® offer the ultimate balance of performance and durability for various applications. Chains will not work on vehicles with a shaft drive.

**520 GDXL(2) Quadra-Ring Lite Chain:**

- Displacement Limit: Up to 650cc
- Tensile strength = 8,500 lb
- 120 links
- Designed to reduce friction up to 40%
- Lighter version of the 520 GDXL for small and mid-sized off-road motorcycles, sportbike, and ATVs

<b>GYT-ACC56-20-01</b> (Gold, 520 GDXL2 X-Ring Lite Chain).....	<b>\$102.95</b>
<b>GYT-ACC56-20-20</b> (Gold, 520 GDXL2 Clip Type Master Link) ..	<b>\$4.95</b>
<b>GYT-ACC56-20-02</b> (Gold, 520 GDXL2 Rivet Type Master Link) ..	<b>\$4.99</b>
<b>GYT-ACC56-20-03</b> (Natural, 520 GDXL2 X-Ring Lite Chain).....	<b>\$109.49</b>
<b>GYT-ACC56-20-04</b> (Natural, 520 GDXL2 Rivet Type Master Link) ..	<b>\$4.99</b>
<b>GYT-ACC56-20-21</b> (Natural, 520 GDXL2 Clip Type Master Link).....	<b>\$4.99</b>

**520 GDO(2) O-Ring Chain:**

- Displacement Limit: Up to 650cc
- Tensile strength = 8,000 lb
- 120 links
- Manufactured by the inventor of the world's first O-ring
- Ideal for small and mid-sized off-road motorcycles, sportbikes, and ATVs
- Includes clip and rivet type master link

<b>GYT-ACC56-20-05</b> (Gold, 520 GDO2 O-Ring Chain).....	<b>\$84.99</b>
<b>GYT-ACC56-20-22</b> (Gold, 520 GDO2 Clip Type Master Link) ..	<b>\$5.99</b>
<b>GYT-ACC56-20-06</b> (Gold, 520 GDO2 Rivet Type Master Link) ..	<b>\$3.49</b>
<b>GYT-ACC56-20-07</b> (Natural, 520 GDO2 O-Ring Chain) .....	<b>\$74.99</b>
<b>GYT-ACC56-20-23</b> (Natural, 520 GDO2 Clip Type Master Link) .....	<b>\$5.99</b>
<b>GYT-ACC56-20-08</b> (Natural, 520 GDO2 Rivet Type Master Link) .....	<b>\$3.49</b>

**520 GMX2 Non-Sealed (Non O-Ring) Chain:**

- Displacement Limit: Up to 500cc
- Tensile strength = 8,400 lb
- 120 links
- Specifically designed for Motocross and Supercross
- Race-tested by Factory Riders to meet today's high performance machines
- High-tech CrH-coated pins for extremely hard outside surface and softer inside to increase the impact strength
- Includes clip and rivet type master link

<b>GYT-ACC56-20-09</b> (Gold, 520 GMX2 Non O-Ring Chain) .....	<b>\$96.49</b>
<b>GYT-ACC56-20-18</b> (Gold, 520 GMX2 Rivet Type Master Link) ..	<b>\$3.99</b>
<b>GYT-ACC56-20-10</b> (Gold, 520 GMX2 Clip Type Master Link) ..	<b>\$2.99</b>
<b>GYT-ACC56-20-11</b> (Natural, 520 GMX2 Non O-Ring Chain) ..	<b>\$87.49</b>
<b>GYT-ACC56-20-17</b> (Natural, 520 GMX2 Rivet Type Master Link) .....	<b>\$3.99</b>
<b>GYT-ACC56-20-12</b> (Natural, 520 GMX2 Clip Type Master Link) .....	<b>\$2.99</b>

**520 GMXL Non-Sealed (Non O-Ring) Chain Lite:**

- Displacement Limit: Up to 250cc
- Tensile strength = 6,600 lb
- 120 links
- Specifically designed for Motocross and Supercross
- Race-tested by Factory Riders to meet today's high performance machines
- Saves weight with less rotating mass
- High-tech CrH-coated pins for extremely hard outside surface and softer inside to increase the impact strength
- Includes clip and rivet type master link

<b>GYT-OSS55-60-48</b> (Gold, 520 GMXL Non O-Ring Chain).....	<b>\$101.49</b>
<b>DBY-ACC56-34-45</b> (Gold, 520 GMXL Rivet Type Master Link) ..	<b>\$3.95</b>
<b>GYT-OSS56-30-98</b> (Gold, 520 GMXL Clip Type Master Link) ..	<b>\$2.99</b>

COVERS

HANDLEBARS & CONTROLS

PERFORMANCE

PROTECTION

SEATS

SPROCKETS & CHAINS

TRIM & ACCENTS

WHEELS

**COVERS**

**HANDLEBARS & CONTROLS**

**PERFORMANCE**

**PROTECTION**

**SEATS**

**SPROCKETS & CHAINS**

**TRIM & ACCENTS**

**WHEELS**

**A. GYTR® MAGNETIC OIL DRAIN PLUG**

Replace the stock steel drain plug with this 6061 billet Magnetic Oil Drain Plug. 60% lighter than stock. Includes a magnet that collects metal shavings, preventing them from circulating in the motor oil. Used by Yamaha Racing Teams.

*Fits '07~'17 YZ125*  
**18P-E51C0-U0-00 (Red).....\$32.99**



**A**

**B. GYTR® BRAKE LINE PINCH**

This pinch replaces the stock steel pinch with a blue anodized billet aluminum piece.

*Fits '06~'17 YZ125*  
**GYT-1P818-15-00 (Blue).....\$40.99**



**B**

**C. GYTR® REAR BRAKE CLEVIS**

This billet rear brake clevis is machined to extremely tight tolerances which minimizes lateral movement or vibration of the rear brake pedal. This clevis allows for more height adjustment and features a titanium clevis pin that is half the weight of stock.

*Fits '09~'17 YZ125*  
**5XC-F72A0-V0-00 (Blue).....\$50.99**



**C**

**D. GYTR® BILLET OFFSET AXLE BLOCKS**

These billet aluminum soft anodized axle blocks are reversible and offset and keep the adjustment bolts from extending too far back when running the rear wheel toward the back of the swingarm for maximum wheelbase.

*Fits '07~'17 YZ125*  
**GYT-2S299-10-00 (Blue).....\$47.99**



**D**

**E. YZ WHEEL KITS\***

These complete original-equipment wheel assemblies are available for Yamaha YZ models. Wheels are factory assembled, ready for installation, and come complete with hub assemblies, spoke sets, rim locks, wave-style brake rotors, and oil seals.

*Fits '09~'17 YZ125*  
**5XC-W2519-L0-00 (Silver) (21" Front).....\$345.99**  
*Fits '99~'17 YZ125*  
**5XC-W2539-L0-00 (Silver) (19" Rear).....\$535.99**



**E**



\*Shown here with both Front and Rear wheels

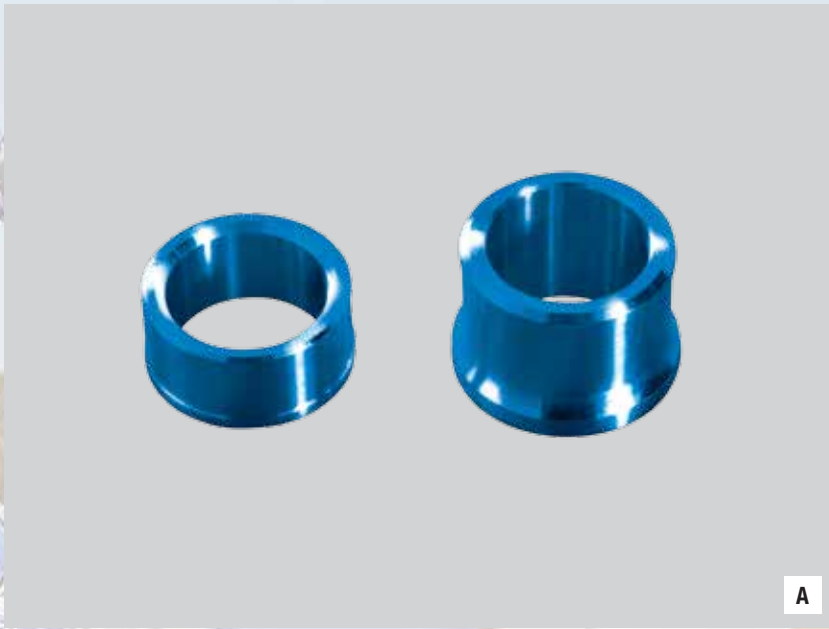

A

**A. GYTR® BILLET WHEEL SPACER KIT**

Get Yamaha Racing Team looks and function with these billet wheel spacers that have integrated dust covers and a seal lip that helps keep the spacers in place during wheel installation/removal.

*Fits '07-'17 YZ125*  
**5XC-F51A0-V0-00** (Blue) (Front) ..... \$40.99

**B. WHEEL SPACERS BY ZETA HIGH PERFORMANCE PRODUCTS**

The 22mm front and 22mm rear wheel spacers by ZETA High Performance Products. Features lightweight aluminum construction, and blue-anodized enhanced styling. Installs in minutes.

*Fits '06-'17 YZ125*  
**DBY-ACC56-34-68** (Blue) (Rear) ..... \$11.95

**C. SUNLINE® RIM LOCK TOWER NUTS**

Machined from aircraft grade 6061-T6 aluminum. Closed nut design seals out mud and water, helping to prevent corrosion. Bevel washer design seats on the rim for a secure fit. Brilliant anodized finish.

*Fits all YZ & WR models*  
**GYT-OSS55-60-23** (Blue) ..... \$20.95

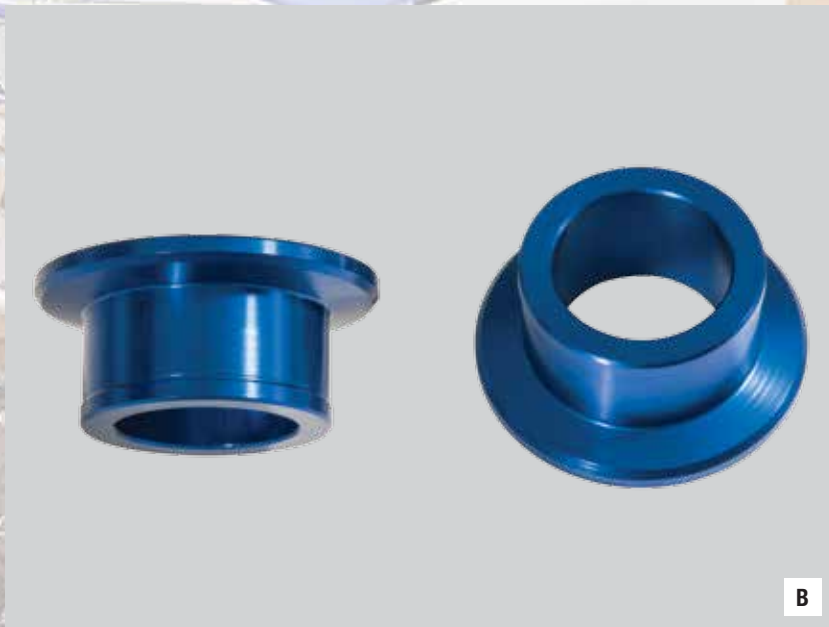

B



C

COVERS

HANDLEBARS & CONTROLS

PERFORMANCE

PROTECTION

SEATS

SPROCKETS & CHAINS

TRIM & ACCENTS

WHEELS

**HANDLEBARS & CONTROLS**

**PERFORMANCE**

**PROTECTION**

**SPROCKETS & CHAINS**

**WHEELS**

**A. SCOTT® MX2 GRIPS - BLACK**

Designed for superior grip and comfort. Features underside waffle and soft-ridged upper patterns. Race proven. Grooved for safety wire. Sold in pairs.

*Fits '02-'17 YZ85*

**ABA-YZRMX-GP-BK (Black) .....\$9.99**

**B. CYCRA® CENTER REACH MOUNT COMPLETE RACER PACK**

These Center Reach Mount (CRM) Complete Racer Packs include CRM Proabend® bars, CRM mount clamps, classic Enduro™ shields, Powergrip bar ends, and Proabend® abrasion guards. Revolutionary patent-pending design. Trademark Proabend® shape. Replaceable integrated plastic abrasion guard. Center-reach clamps provide maximum bite to secure hand guards and allow for superior clearance on a wide range of bars. Powergrip alloy bar ends fit standard 7/8" and oversized bars.

*Fits all 2-stroke and 4-stroke YZ models with 1-1/8" bars and stock width*

**GYT-OSS56-30-48 (White) .....\$132.95**

**GYT-OSS56-30-49 (Blue) .....\$132.95**



**A**



**B**





A

**A. CYCRA® ALLOY STEALTH COMPLETE RACER PACK**

Complete Racer Pack includes shields, brackets, and hardware. Aircraft quality 6061 T-6 aluminum brackets. Slim, low-profile handshield design. Simple and easy to install. Rotating bolt plate allows brackets to be mounted above or below levers.

*Fits all 2-stroke and 4-stroke YZ models with 1-1/8" bars and stock width*

- GYT-OSS56-30-59 (Black) .....\$51.95
- GYT-OSS56-30-60 (White) .....\$51.95
- GYT-OSS56-30-61 (Blue) .....\$51.95

**B. GYTR® 10" CROSSBAR PAD**

Designed for handlebars with crossbar. Printed on scratch resistant, 15 mil. vinyl featuring the Yamaha logo.

*Fits all Off-road models with crossbar-equipped handlebars*

- GYT-CROSS-BR-02 (Blue).....\$12.99

**C. GYTR® YAMAHA FACTORY RACING CLAMP COVER FOR 1-1/8" HANDLEBARS**

Printed on scratch-resistant 15-mil vinyl, featuring the Factory Racing logo. 10" long. For 1-1/8" handlebars.

*For all Off-road Motorcycles with 1-1/8" handlebars*

- GYT-5XC25-18-BL (Blue).....\$21.99



B



C

HANDLEBARS & CONTROLS

PERFORMANCE

PROTECTION

SPROCKETS & CHAINS

WHEELS

**A. ATHENA® SUPER MINI CYLINDER KITS**

This complete kit includes a new precision-made, stroked crankshaft and nickel-carbide plated cylinder with enlarged water passages and revised porting designed specifically for this kit. The cylinder head is also newly designed with increased water passages. Kit has everything needed for a complete installation except required crankcase machining. Includes crankshaft, connecting rod, cylinder, cylinder head, precision-made piston with rings, clips, wrist pin, studs, nuts, O-rings, and gaskets (different thickness base gaskets to adjust squish). YZ models are for closed-course use regardless of modification.

*Fits '05~'17 YZ85*

<b>DBY-ACC56-34-17</b> (112cc Cylinder/Crank Kit).....	<b>\$915.49</b>
<b>DBY-ACC56-34-23</b> (112cc Cylinder).....	<b>\$404.95</b>
<b>DBY-ACC56-34-24</b> (112cc Cylinder Head).....	<b>\$204.95</b>
<b>DBY-ACC56-34-25</b> (112cc Crankshaft).....	<b>\$228.95</b>
<b>DBY-ACC56-34-16</b> (105cc Cylinder Kit) (Shown).....	<b>\$696.49</b>
<b>DBY-ACC56-34-21</b> (105cc Cylinder Kit).....	<b>\$391.99</b>
<b>DBY-ACC56-34-22</b> (105cc Cylinder Head).....	<b>\$204.95</b>
<b>DBY-ACC56-34-20</b> (105/112cc Top End Gasket Kit).....	<b>\$31.49</b>
<b>DBY-ACC56-34-18</b> (105/112cc Piston Kit A).....	<b>\$201.95</b>
<b>DBY-ACC56-34-19</b> (105/112cc Piston Kit B).....	<b>\$199.95</b>

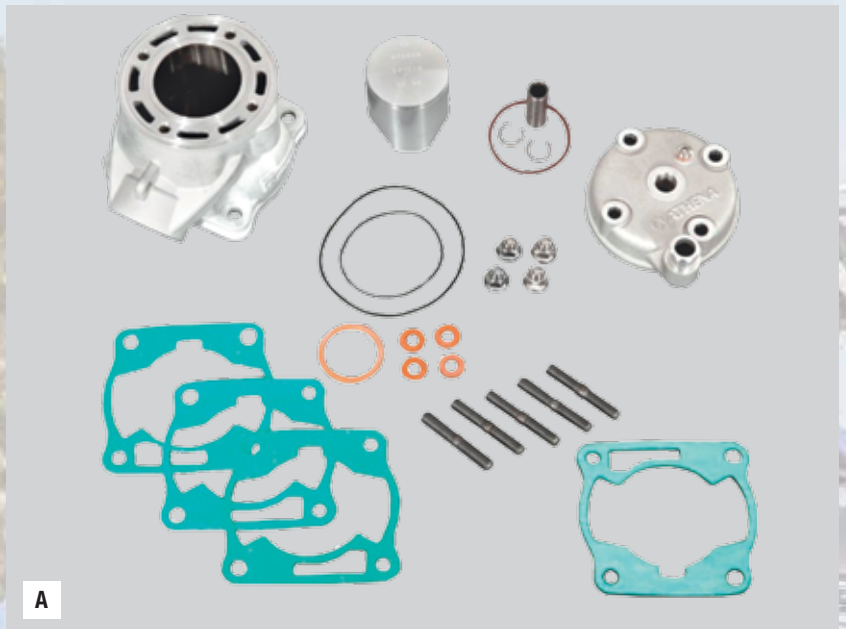

**A**

**B. YAMAHA GENUINE TOP END GASKET KIT**

These original-equipment Top End and Bottom End Gasket Kits were designed for convenience and total savings. Kits include the necessary gaskets, seals, and O-rings needed to reassemble your engine. They also include a complete part number list of all gaskets, seals, and O-rings for an in-depth engine overhaul.

*Fits '05~'16 YZ85*

<b>5PA-W0001-00-00</b> .....	<b>\$25.99</b>
------------------------------	----------------



**B**

**C. VFORCE®3 HIGH PERFORMANCE REED VALVE SYSTEM**

The VForce® 3 High Performance Reed Valve System is ultra efficient and provides increased throttle response and acceleration. Replacement Petals also available. (See below) YZ models are for closed-course use regardless of modification.

*Fits '05~'17 YZ85*

<b>DBY-ACC56-34-29</b> .....	<b>\$171.95</b>
------------------------------	-----------------



**C**

**D. VFORCE®3 REPLACEMENT PETALS**

*Fits '05~'17 YZ85*

<b>DBY-ACC56-34-30</b> .....	<b>\$72.49</b>
------------------------------	----------------



**D**



A

**A. GYTR® TWO-STAGE FOAM AIR FILTER**

High-flow, two-layer foam filter offers optimized filtration while maximizing airflow. Increases performance. Filter is completely washable and reusable. Service with Yamaha Genuine Foam Filter Oil. This accessory is restricted to closed-course use.

*Fits '05-'17 YZ85*  
**GYT-5PA95-00-00** .....\$27.49

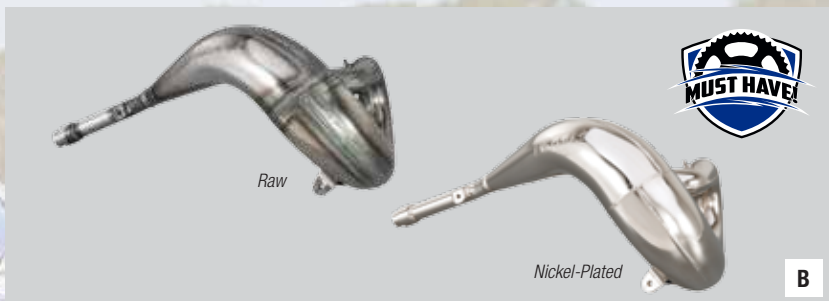

B

**B. GYTR® BY FMF® RACING 2-STROKE EXHAUST PIPES**

GYTR by FMF® Racing 2-Stroke Exhaust Pipes features expansion chambers that are developed to maximize power gains throughout the rpm range and provide improved throttle response as well as a broader, smoother power band all providing a more tractable power delivery. Pipes feature the stamped GYTR by FMF® logo, hand-pounded seams, natural and unplanted carbon steel finish, materials and manufacturing techniques that make a true 'Race Spec' pipe. Includes O-rings and is lighter than stock. Designed to be used with the GYTR by FMF® Racing 2-Stroke Exhaust Silencer (sold separately). YZ models are for closed-course use regardless of modification.

*Fits '02-'17 YZ85*  
**5PA-E46A0-T0-00 (Raw)** .....\$229.99  
**5PA-E46A0-V0-00 (Nickel-Plated)** .....\$235.99



C

**C. GYTR® BY FMF® RACING 2-STROKE EXHAUST SILENCERS**

The GYTR by FMF® Racing 2-Stroke Exhaust Silencer was designed to work with the GYTR Racing 2-Stroke Exhaust Pipes. Improves performance. Features button-head screws for easy maintenance. Lighter than stock. Features the GYTR by FMF® badge. YZ models are for closed-course use regardless of modification.

*Fits '02-'17 YZ85*  
**5PA-E47A0-T0-00 (Aluminum) (Shown)** .....\$133.99  
*Fits '05-'17 YZ85*  
**GYT-OSS56-32-81 (Titanium)** .....\$179.99

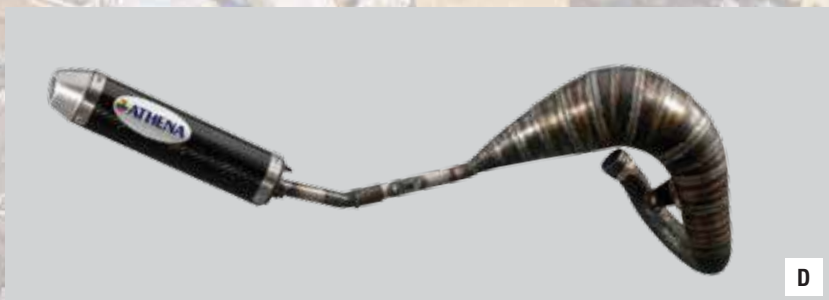

D

**D. ATHENA® SUPER MINI 105/112CC EXHAUST SYSTEM**

This exhaust system was designed and built in conjunction with 105cc/112cc Super Mini engine kits. The thin wall cone and stamp construction optimizes strong mid and top-end power and gives a pure raw factory look while improving performance over stock and other aftermarket YZ85 exhaust systems. The rebuildable silencer is constructed from lightweight carbon fiber and stainless steel and uses a unique adjustable O-ring bracket for a perfect fit. Exhaust Pipe and Silencer sold separately. (Pipe & Silencer shown). YZ models are for closed-course use regardless of modification.

*Fits '02-'17 YZ85 with 105cc or 112cc Super Mini Cylinder Kit*  
**DBY-ACC56-34-26 (Pipe)** .....\$279.95  
*Fits '02-'17 YZ85 with 105cc or 112cc Super Mini Cylinder Kit*  
**DBY-ACC56-34-36 (Silencer)** .....\$132.95



E

**E. GYTR® BILLET CLUTCH BASKET**

Precision-machined from the highest grade of aluminum and then anodized to achieve an exceptionally hard, wear-resistant surface. This clutch basket provides amazing, race-proven durability.

*Fits '05-'17 YZ85*  
**GYT-5PA56-10-01** .....\$241.95



F

**F. GYTR® BILLET INNER CLUTCH HUB**

Precision machined from the highest grade of aluminum, then hard anodized to achieve an exceptionally hard, wear-resistant surface for amazing race-proven durability. Additional oil passages help improve clutch performance and contribute to a 20% weight reduction and less rotational mass for improved acceleration.

*Fits '05-'17 YZ85*  
**GYT-5PA56-40-00** .....\$300.99

**HANDLEBARS & CONTROLS**

**PERFORMANCE**

**PROTECTION**

**SPROCKETS & CHAINS**

**WHEELS**

**A. GYTR® BILLET CLUTCH PRESSURE PLATE**

Precision-machined from the highest grade of aluminum, then hard anodized to achieve an exceptionally hard, wear-resistant surface for amazing race-proven durability. Additional oil passages help improve clutch performance and also contribute to a 30% weight reduction and less rotational mass for improved acceleration.

*Fits '05-'17 YZ85*  
**GYT-5PA56-20-00** .....\$164.95

**B. YAMAHA GENUINE OFF-ROAD CLUTCH KITS**

These complete Yamaha Clutch Kits include the plates, springs, and gaskets, ready to install. Refer to service manual for installation instructions.

*Fits '05-'16 YZ85*  
**5PA-W001G-00-00** .....\$124.99

**C. GYTR® BILLET CLUTCH COVER**

Precision-machined from the highest grade of aluminum and then anodized to achieve an exceptionally hard, wear-resistant surface.

*Fits '05-'17 YZ85*  
**GYT-5PA35-10-AL** .....\$136.99

**D. YAMAHA GENUINE FRONT FORK SEAL KITS**

These Yamaha Genuine Fork Seal Kits come with the original equipment fork and dust seals. Don't settle for the next best thing from the aftermarket use Yamaha Genuine Fork Seal Kits for longer life and less maintenance. Don't forget to order the proper fork oil for your bike, as well. Yamaha Fork Oils are formulated specifically for your model and deliver the highest suspension performance possible.

*Fits '02-'16 YZ85*  
**4ES-W003B-00-00** .....\$56.99

**E. YAMAHA GENUINE BEARING KITS**

These Yamaha Genuine Bearing Kits come with all of the components needed to rebuild the swingarm pivot, shock linkage, and shock bearings. Kits include all of the original equipment bearings, seals, O-rings, and collars your bike came with. Unlike some of the aftermarket companies that use a lower quality bearing, these bearings are O-ring sealed to prevent intrusion of dirt, mud, and water and are made of top quality materials. So, if you don't want to do the job again and in half the time your original bearings lasted, then use these Yamaha Genuine kits.

*Fits '03-'16 YZ85*  
**1SN-W002E-00-00** (Shock Linkage Bearing Kits) (Shown) .....\$148.99

*Fits '02-'16 YZ85*  
**1SN-W002C-00-00** (Swingarm Pivot Bearing Kits) .....\$79.99



**A**



**B**



**C**



**D**



**E**



A

**A. CARBON FIBER MX GLIDE PLATE BY LIGHTSPEED®**

Durable, lightweight carbon fiber MX glide plate provides a smooth surface for "gliding" over obstacles. Uses stock hardware for mounting.

Fits '05-'17 YZ85

**GYT-OSS56-31-64.....\$101.95**

**B. CARBON FIBER FRAME GUARDS BY LIGHTSPEED®**

Provides "factory appearance" and helps protect the frame and rear brake master cylinder from abrasion. Sold as a set.

Fits '05-'17 YZ85

**GYT-OSS56-31-65.....\$101.95**

**C. GYTR® REAR SPROCKETS**

These GYTR Rear Sprockets are made from 7075-T6 billet aluminum CNC-machined for maximum fit accuracy. Features a radial mud groove etched just inside the sprocket teeth to shed mud and grit which saves weight and increases chain life. Sprocket sizes other than stock are for closed-course competition only on '06 and later off-road models and all street legal models. Changing the final drive ratio affects exhaust emissions and also affects speedometer readings.

Fits '02-'17 YZ85

**DBY-ACC56-33-05 (Blue, 45T) (Shown).....\$61.95**

**DBY-ACC56-33-06 (Blue, 51T).....\$61.95**

**DBY-ACC56-33-07 (Blue, 53T).....\$61.95**

**GYT-OSS56-30-16 (Blue, 46T).....\$61.95**

**GYT-OSS56-30-17 (Blue, 47T).....\$62.49**

**GYT-OSS56-30-18 (Blue, 48T).....\$62.49**

**GYT-OSS56-30-19 (Blue, 49T).....\$62.49**



B

**D. GYTR® FRONT SPROCKETS BY TALON**

Made from heat-treated chromoly steel and CNC-machined to extremely high tolerances. Zinc finish to help combat corrosion. Sprockets feature self-cleaning grooves to shed mud and grit, as well as reduce weight while maintaining strength. Sprocket sizes that increase the final drive ratio over stock are for closed-course competition only on '06 and later models because regulated exhaust emissions are affected.

Fits '05-'17 YZ85

**GYT-OSS56-32-69 (Silver, 13T).....\$26.49**

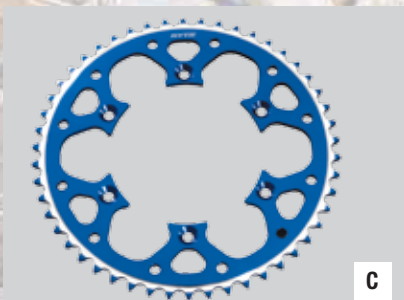

C



D

**E. GYTR® ULTRA-HIGH PERFORMANCE RACING CHAINS BY EK®**

GYTR Ultra-High Performance Racing Chains & Links by EK® offer the ultimate balance of performance and durability for various applications. Chains will not work on vehicles with a shaft drive.

**428 GMX Non-Sealed (Non O-Ring) Chain:**

- Displacement Limit: Under 200cc
- Tensile strength = 5,000 lb
- 120 links/ 135 links (Big Wheel)
- Intended for smaller displacement off-road applications
- High-quality replacement chain for racing or trail usage
- Comes with solid bushings, solid rollers, and heat-treated steel alloys

**GYT-OSS56-31-93 (Gold, 428 GMX Non O-Ring Chain, Big Wheel Conversion).....\$67.49**

**GYT-OSS56-31-70 (Gold, 428 GMX Non O-Ring Chain).....\$59.49**

**GYT-OSS56-31-73 (Gold, 428 GMX Clip Type Master Link).....\$1.99**

**GYT-OSS56-31-92 (Natural, 428 GMX Non O-Ring Chain, Big Wheel Conversion).....\$56.99**

**GYT-OSS56-31-72 (Natural, 428 GMX Clip Type Master Link).....\$1.99**



E

HANDLEBARS & CONTROLS

PERFORMANCE

PROTECTION

SPROCKETS & CHAINS

WHEELS

**A. SUPER MINI BIG WHEEL CONVERSION KITS AND INDIVIDUAL COMPONENTS**

Parts to convert the YZ80/85 series models to the big wheel specification. Available as individual components or combined kits (Chassis Kit, Front Hub Kit, Front Wheel Kit, Rear Hub Kit, Rear Wheel Kit).

**NOTE:** Need 2 Special Rubber Bushings, 2 Bearings, 4 Oil Seals, 2 Plugs.

*Fits '02~'17 YZ85*

5PA-F11A0-V0-00 (Chassis Kit) (Shown) .....	\$811.95
5PA-F51C0-V0-00 (Front Wheel Kit) .....	\$258.95
5PA-F51J0-V0-00 (Front Hub Kit) .....	\$157.95
5PA-F53T0-V0-00 (Rear Hub Kit) .....	\$176.95
5PA-F53P0-V0-00 (Rear Wheel Kit) .....	\$300.95

Individual components to convert the YZ80/85 series models to the big wheel specification.

*Fits '02~'17 YZ85*

1T2-25394-00-00 (Larger Spacer Bead) .....	\$48.06
4LB-25104-00-00 (Front Spoke Set) .....	\$45.99
4LB-22110-01-00 (Swingarm) .....	\$869.62
4LB-25304-00-00 (Rear Spoke Set) .....	\$52.73
90338-10150-00 (Plug) .....	\$3.59
90385-17042-00 (Special Rubber Bushing) .....	\$10.53
90387-1200U-00 (Collar III) .....	\$9.78
90387-127J7-00 (Collar II) .....	\$8.31
90387-127J8-00 (Collar I) .....	\$11.65
93109-17071-00 (Oil Seal) .....	\$6.90
93317-21746-00 (Bearings) .....	\$16.96
94209-16003-00 (Rear 16" Tube) .....	\$13.87
94227-19292-00 (Front 19" Tube) .....	\$19.04
94327-19111-00 (Front Rim Band 2.00-19") .....	\$8.77
94330-16058-00 (Rear Rim Band 1.60-16") .....	\$11.44
94414-19521-00 (Front Rim) .....	\$264.17
94418-16522-00 (Rear Rim) .....	\$267.23
9Y5-81971-21-00 (428 Chain) .....	\$88.95
94681-97001-00 (428 Master Link) .....	\$3.04
99999-03068-00 (Longer Rear Brake Line) .....	\$111.26
99999-03467-00 (Longer Front Brake Line) .....	\$125.29



A

**B. TALON® SUPER MINI WHEEL ASSEMBLIES - 16" REAR WHEEL/ 19" FRONT WHEEL**

Talon® wheels are the ultimate combination of strength and reliability. The Talon® blue lightweight hub is CNC-machined from aircraft quality billet aluminum and is laced to a black Takasago Excel rim with high-quality stainless steel spokes and nipples for superior durability.

*Fits '02~'17 YZ85*

GYT-OSS56-31-32 (Black)(Front) .....	\$568.49
GYT-OSS56-31-33 (Black)(Rear) .....	\$617.49



B

**C. SUNLINE® RIM LOCK TOWER NUTS**

Machined from aircraft grade 6061-T6 aluminum. Closed nut design seals out mud and water, helping to prevent corrosion. Bevel washer design seats on the rim for a secure fit. Brilliant anodized finish.

*Fits all WR models*

GYT-OSS55-60-23 (Blue) .....	\$20.95
------------------------------	---------



C



A

**A. GYTR® 10" CROSSBAR PAD**

Designed for handlebars with crossbar. Printed on scratch resistant, 15 mil. vinyl featuring the Yamaha logo.

*Fits all Off-road models with crossbar-equipped handlebars*

**GYT-CROSS-BR-02** (Blue).....\$12.99



B

**B. GYTR® YAMAHA FACTORY RACING CLAMP COVER FOR 1-1/8" HANDLEBARS**

Printed on scratch-resistant 15-mil vinyl, featuring the Factory Racing logo. 10" long. For 1-1/8" Handlebars.

*For all Off-road Motorcycles with 1-1/8" Handlebars*

**GYT-5XC25-18-BL** (Blue).....\$21.99



C

**C. TWO-STAGE FOAM AIR FILTER**

High-flow, two-layer foam filter offers optimized filtration while maximizing airflow. Increases performance. Filter is completely washable and reusable. Service with Yamaha Genuine Foam Filter Oil. This accessory is restricted to closed-course use.

*Fits '00~'17 TT-R125*

**GYT-5HP95-00-00**.....\$25.95

*Fits '99~'06 TT-R250*

**GYT-5GF95-00-00**.....\$24.95



D

**D. GYTR® HIGH FLOW AIR FILTERS**

The GYTR TT-R High Flow Air Filter was developed to be used with or without the Performance Carburetor Kit. GYTR Jet Kit recommended with filter installation. Comes with pre-filter. This accessory is restricted to closed-course use.

*Fits '06~'17 TT-R50E (for stock configuration)*

**GYT-1P695-01-00**.....\$20.95

*Fits '06~'17 TT-R50E (for GYTR Big Bore Kit)*

**GYT-1P695-02-00**.....\$20.95

HANDLEBARS & CONTROLS

PERFORMANCE

PROTECTION

SPROCKETS & CHAINS

TRIM & ACCENTS

HANDLEBARS  
& CONTROLS

PERFORMANCE

SPROCKETS  
& CHAINS

TRIM &  
ACCENTS

**A. GYTR® HIGH FLOW AIR FILTERS**

The GYTR TT-R High Flow Air Filter was developed to be used with or without the Performance Carburetor Kit. GYTR Jet Kit recommended with filter installation. Comes with pre-filter. This filter for stock carburetor configuration.

*Fits '08-'17 TT-R110E*

**GYT-5B695-00-00** (for stock carb configuration).....**\$36.95**

**GYT-5B695-10-00** (for performance carb configuration) .....**\$38.95**

**B. GYTR® PRE-FILTER**

Less maintenance in dusty conditions. Pre-filters dirt with no critical airflow or power loss.

*Fits '08-'17 TT-R110E*

**GYT-5B695-11-BL**.....**\$18.95**

**C. GYTR® JET KITS**

Adjust your stock carburetor for riding conditions with this GYTR Jet Kit. Designed to be used in conjunction with the GYTR High Flow Air Filter. For closed-course competition only.

*Fits '08-'17 TT-R110E*

**GYT-5B698-00-00**.....**\$43.99**



**A**



**B**



**C**





A

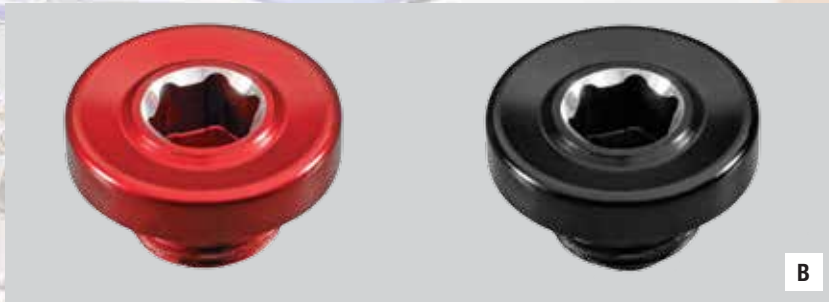

B



C



D

**A. GYTR® ULTRA-HIGH PERFORMANCE RACING CHAINS BY EK®**

GYTR Ultra-High Performance Racing Chains & Links by EK® offer the ultimate balance of performance and durability for various applications. Chains will not work on vehicles with a shaft drive.

**520 GMX2 Non-Sealed (Non O-Ring) Chain:**

- Displacement Limit: Up to 500cc
- Tensile strength = 8,400 lb
- 120 links
- Specifically designed for Motocross and Supercross
- Race-tested by Factory Riders to meet today's high performance machines
- High-tech CrH-coated pins for extremely hard outside surface and softer inside to increase the impact strength
- Includes clip and rivet type master link

*Fits '06 ~ '17 TT-R230; '99 ~ '06 TT-R250*

<b>GYT-ACC56-20-09</b> (Gold, 520 GMX2 Non O-Ring Chain) .....	<b>\$96.49</b>
<b>GYT-ACC56-20-18</b> (Gold, 520 GMX2 Rivet Type Master Link) .....	<b>\$3.99</b>
<b>GYT-ACC56-20-10</b> (Gold, 520 GMX2 Clip Type Master Link) .....	<b>\$2.99</b>
<b>GYT-ACC56-20-11</b> (Natural, 520 GMX2 Non O-Ring Chain) .....	<b>\$87.49</b>
<b>GYT-ACC56-20-17</b> (Natural, 520 GMX2 Rivet Type Master Link) .....	<b>\$3.99</b>
<b>GYT-ACC56-20-12</b> (Natural, 520 GMX2 Clip Type Master Link) .....	<b>\$2.99</b>

**520 GMXL Non-Sealed (Non O-Ring) Chain Lite:**

- Displacement Limit: Up to 250cc
- Tensile strength = 6,600 lb
- 120 links
- Specifically designed for Motocross and Supercross
- Race-tested by Factory Riders to meet today's high performance machines
- Saves weight with less rotating mass
- High-tech CrH-coated pins for extremely hard outside surface and softer inside to increase the impact strength
- Includes clip and rivet type master link

*Fits '06 ~ '17 TT-R230; '99 ~ '06 TT-R250*

<b>GYT-OSS55-60-48</b> (Gold, 520 GMXL Non O-Ring Chain) .....	<b>\$101.49</b>
<b>DBY-ACC56-34-45</b> (Gold, 520 GMXL Rivet Type Master Link) .....	<b>\$3.99</b>
<b>GYT-OSS56-30-98</b> (Gold, 520 GMXL Clip Type Master Link) .....	<b>\$2.99</b>

**428 GMX Non-Sealed (Non O-Ring) Chain:**

- Displacement Limit: Under 200cc
- Tensile strength = 5,000 lb
- 120 links/ 135 links (Big Wheel)
- Intended for smaller displacement off-road applications
- High-quality replacement chain for racing or trail usage
- Comes with solid bushings, solid rollers, and heat-treated steel alloys

*Fits '00 ~ '17 TT-R125*

<b>GYT-OSS56-31-70</b> (Gold, 428 GMX Non O-Ring Chain) .....	<b>\$59.49</b>
<b>GYT-OSS56-31-73</b> (Gold, 428 GMX Clip Type Master Link) .....	<b>\$1.99</b>

**B. GYTR® 14MM TIMING COVER PLUG**

These anodized 6061 billet aluminum timing plugs replace the stock plastic plugs.

*Fits '06 ~ '17 TT-R230; '06 ~ '17 TT-R125 models*

<b>18P-E51B0-V0-00</b> (Red) .....	<b>\$30.95</b>
<b>5XC-E51B0-V0-00</b> (Black) .....	<b>\$30.99</b>

*Fits '06 ~ '16 TT-R230; '06 ~ '16 TT-R125 All models*

<b>GYT-2S235-14-AL</b> (Blue) (Not Shown) .....	<b>\$28.99</b>
---	----------------

**C. GYTR® 20MM OIL FILL CAPS**

Anodized 6061 billet aluminum plug replaces stock plastic cap.

*Fits '06 ~ '17 TT-R230*

<b>5XC-E53A0-V0-00</b> (Black) .....	<b>\$29.95</b>
<b>GYT-2S235-01-00</b> (Blue) .....	<b>\$30.99</b>

**D. GYTR® 32MM ENGINE COVER PLUG**

These anodized 6061 billet aluminum timing plugs replace the stock plastic plugs.

*Fits '06 ~ '17 TT-R230; '06 ~ '17 TT-R125 All models*

<b>GYT-5XC35-32-AL</b> (Blue) .....	<b>\$31.95</b>
-------------------------------------	----------------

**PERFORMANCE**

**PROTECTION**

**TRIM & ACCENTS**

**A. GYTR® BY FMF® MINI POWERCORE® 4 MUFFLER**

This "Mini" PowerCore®4 is the best "bang for your buck" bolt-on muffler for your mini. You'll swear the motor has been bored and stroked with the first twist of the throttle. Has an aircraft-grade aluminum can, durable stainless steel header, high-flow stainless steel core and formed end cap. Comes with USFS-approved spark arrester for sanctioned off-road competition events that require one. Lighter than the stock muffler. For closed-course competition use only.

*Fits '08~'17 TT-R110E*  
**5B6-E46D0-V0-00**.....\$229.99

**B. GYTR® ALUMINUM GLIDE PLATE**

These plates help glide your bike over obstacles and provide added protection for the lower frame and engine components.

*Fits '08~'17 TT-R110E*  
**GYT-5B634-00-AL**.....\$99.99

**C. GYTR® 14MM TIMING COVER PLUG**

These anodized 6061 billet aluminum timing plugs replace the stock plastic plugs.

*Fits '08~'17 TT-R110E*  
**18P-E51B0-V0-00 (Red) (Shown)**.....\$30.95

*Fits '08~'17 TT-R110E*  
**5XC-E51B0-V0-00 (Black)**.....\$30.99

*Fits '08~'17 TT-R110E*  
**GYT-2S235-14-AL (Blue)**.....\$30.99

**D. GYTR® 32MM ENGINE COVER PLUG**

These anodized 6061 billet aluminum timing plugs replace the stock plastic plugs.

*Fits '08~'17 TT-R110E*  
**GYT-5XC35-32-AL (Blue)**.....\$31.95



**A**



**B**



**C**



**D**



GYTR – Four letters that spell exhilaration... well, not literally – they stand for "Genuine Yamaha Technology Racing," and whether you're flying through the whoops or leaning into the chicane, you'll experience the over 40 years of bar-gripping, hair-standing, industry-leading technology and expertise GYTR engineers bring to every performance accessory they design.

From the early days of the "GYT KIT" to today's GYTR, Yamaha's relentless quest for the podium, mixed with a passion to win, has driven Yamaha engineers to design and develop race-caliber parts that could push already-dominant Yamaha machines to the next level.

## **GYTR vs. Aftermarket**

Aftermarket is for amateurs... GYTR's technology has helped propel Yamaha Factory Race Teams to more podiums than any other brand – it's not just a statement, it's a reality! Nowhere else in Powersports do you find true race-proven performance mixed with title-winning accessories developed by an OEM and available to all Yamaha riders.

GYTR accessories are designed in tandem with your Yamaha for unmatched integration, using state-of-the-art materials like carbon fiber and aircraft-grade aluminum. You'll also find technologies like REM<sup>®</sup> finishing, a finish technology that, on a nano level, allows for better lubrication of internal engine components – to eke out even more horsepower for that slight extra edge.

Once the design is complete, GYTR items undergo the highest level of performance and durability analysis (we are talking grueling, hardcore testing here) for unmatched quality.

Why would you chance using an aftermarket accessory? GYTR accessories are the only Yamaha-backed, expertly developed products built for your Yamaha... anything else is just amateur.

Two-wheels or four, competition or fun, GYTR one-ups your ride.



UNIVERSAL  
ACCESSORIES



ELECTRICAL

MISCELLANEOUS

RAMPS

STANDS & MATS

STRAPS & TIE DOWNS

**A. YAMAHA DELUXE HOUR METER**

The Yamaha Engine Meter helps you keep track of your engine's operating hours. Also includes pre-programmed service intervals at 10 hours (initial) and every 50 hours thereafter. A flash alert displays for a 2-hour period upon reaching the specified interval. Works with all Yamaha 2-stroke and 4-stroke models, including Yamaha gasoline generators and pumps. Combined hour meter and tachometer option available for 4-stroke models only.

ENG-METER-2C-01 .....\$54.99

**B. YAMAHA DELUXE HOUR METER & TACHOMETER**

The Yamaha Engine Meter helps you keep track of your engine's operating hours. Also includes pre-programmed service intervals at 10 hours (initial) and every 50 hours thereafter. A flash alert displays for a 2-hour period upon reaching the specified interval. Works with all Yamaha 2-stroke and 4-stroke models, including Yamaha gasoline generators and pumps. Combined hour meter and tachometer option available for 4-stroke models only.

ENG-METER-4C-01 .....\$58.99

**C. STANDARD HOUR METER**

This Standard Hour Meter is a must-have for logging time on your Yamaha engine. Hour meter function only (no service alerting function). Installs in minutes and is mounted in the engine compartment.

*Fits all Yamaha two-stroke and four-stroke gas models*

ENG-HOURS-00-00 .....\$53.99

**D. ATZ7-8 BATTERY BY ANTIGRAVITY BATTERIES®**

Increasing performance for competition usually means improving the motorcycle or ATV's power-to-weight ratio by either adding more power or taking away weight. However, this can be expensive. One of the easiest and least expensive ways to eliminate pounds of weight is often overlooked – the battery. Now there is a much lighter alternative, the lithium-iron-phosphate (LiFePO<sub>4</sub>) batteries from Antigravity Batteries®. While a traditional YTZ10 lead/acid battery for a YZF-R1 or YZF-R6 weighs about 8 lb Antigravity's equivalent lithium-iron battery weighs about 2 lb, about 75% lighter and an easy savings of nearly 6 lbs!

Additional Features:

- Size: Direct replacements for the OE battery with the same case dimensions and connectors, providing a perfect fit and 70-80% weight savings
- Better Starting: Larger ignition spark and higher voltage on the starting pulse than a lead/acid battery
- No Maintenance: No liquids to spill and no trickle charging necessary to keep the battery charged
- Durable: Will not be damaged by vibration or heat like a lead/acid battery while also being completely waterproof
- Non-Toxic: Chemical make-up does not contain highly toxic materials such as acid or lead
- Warranty: Manufacturer's prorated one-year race limited warranty

OptiMate® Lithium-Iron Battery Charger, sold separately, required for charging this battery.

*Useable for '09, '11~'13; '15~'17 WR250F; '09~'17 WR250R; '09, '11 WR250X; '09; '11~'17 WR450F; '15~'17 WR250FX; '16~'17 YZ450FX*

DBY-ACC51-70-03 ..... \$179.99

A



B



C



D





A

### A. MICRO-START™ XP-1 BY ANTIGRAVITY BATTERIES®

The Micro-Start™ XP-1 PPS (Personal Power Supply) is the world's smallest jump starter and personal power supply. So small it fits in your pocket, yet so powerful it can jump start cars, trucks, motorcycles, ATVs, side-by-sides, snowmobiles, boats, and personal watercraft. It also charges and powers most electronic devices such as laptops, cell phones, iPad® mobile digital devices and other tablets, digital readers, Bluetooth® devices, GPS devices, MP3 players, cameras, and more. So whether you're working, riding, driving, camping, or boating ... you've got peace of mind with the Micro-Start™ XP-1 right there in your pocket!

#### Features include:

- Small and lightweight — 6" long x 2-7/8" wide x 1" tall and weighs just 14 oz.
- 3 on-board power ports: 19V for laptops, 12v standard output for all 12V accessories, and USB 5v output
- Lighted battery capacity indicator
- Built-in over-charge and over-discharge protection for long battery life
- Automatic power-off feature when not in use
- Built-in high-power LED flashlight with two pre-programmed flash patterns, including an S.O.S. pattern

#### Kit includes:

- Micro-Start™ XP-1 unit
- Slim leather carrying case
- Detachable mini jumper clamps
- Black universal cable with 8 different detachable tips to fit different brands of laptop charging ports
- Black universal cable for all 12V accessories
- White universal USB cable with 8 different detachable tips to fit most 5V USB-chargeable electronics
- Home charger
- Mobile charger (for charging via the cigarette lighter socket in your vehicle)

DBY-ACC56-24-57 ..... \$159.99

### B. MICRO-START™ MINI XP-5 BY ANTIGRAVITY BATTERIES®

The Micro-Start™ XP-5 "Mini" is as small as a cell phone and weighs just 8 ounces but has so much power it can jump start motorcycles, ATVs, UTVs, snowmobiles, watercraft, even a V6 truck! It can also charge and power all of your USB-powered devices like smartphones, tablets, action cameras, GPS devices, MP3 players, Bluetooth® devices, and more.

#### Features include:

- Small and lightweight: only 5" long x 2-7/8" wide x 1/2" tall, and weighs just 8 oz.
- 5V 2A USB port for charging all USB devices
- High-power LED flashlight (with 2 flash patterns)
- Lighted battery capacity indicators (similar to a fuel gauge)
- Built-in over-charge and over-discharge, reverse polarity, short circuit protections
- Automatic power-off feature when not in use
- 150 Amp - 300 Peak Amp jump starting ability

#### Kit includes:

- Nylon Carry Case with elastic bands to hold parts in place
- Micro-Start™ XP-5 Mini Unit
- Detachable Mini Jumper Clamps
- Universal 4-into-1 USB Cable (white) with four of the most common tips to fit 5V USB-chargeable electronics: Mini USB, Micro USB, Apple Lightning® (new 8-pin type), and 30-pin connectors
- Mobile Charger for plugging into cigarette lighter socket
- Home Charger for wall charging (compatible with 110V and 220V)

DBY-ACC56-25-01 ..... \$109.99



B

iPad and Lightning are registered trademarks of Apple Inc.

ELECTRICAL

MISCELLANEOUS

RAMPS

STANDS &amp; MATS

STRAPS &amp; TIE DOWNS

ELECTRICAL

MISCELLANEOUS

RAMPS

STANDS & MATS

STRAPS & TIE DOWNS

**A. MICRO-START™ XP-10  
BY ANTIGRAVITY BATTERIES®**

The Micro-Start™ XP-10 PPS (Personal Power Supply) and Jump Starter features up to 600 peak amps of jump-start/booster power and has 18,000 milliamps of capacity. It offers 19V, 12V, and 5V USB ports to charge most devices and has a high-power LED flashlight with S.O.S. flash patterns. This high-power lithium-ion booster pack is small enough to fit in your pocket yet so powerful it can jump start all motorcycles, ATVs, UTVs, snowmobiles, watercraft, boats, V8 trucks, and even diesel motors up to 8 liters. It also powers and charges laptops (not 16v Apple® laptops), cell phones, iPhone® mobile digital devices, tablets, Bluetooth® devices, cameras, PDAs, GPS devices, MP3 players, digital readers, gaming systems, and more. The pocket-sized Micro-Start™ weighs just over a pound (only 18 oz.) and has a nice ergonomic design. Just charge it and easily take back-up power with you wherever you go.

**Features include:**

- Small and lightweight: 9" long x 3.2" wide x 1.2" tall and weighs just 18 oz.
- 19V output port for laptops
- 12V standard output port
- 5V USB port
- High-power LED Flashlight (with 2 flash patterns)
- Lighted battery indicator
- Built-in over-charge and over-discharge, reverse polarity, short circuit protections
- Automatic power-off feature when not in use

**Kit includes:**

- Slim Leather Carry Case
- Micro-Start™ XP-10 Unit
- Detachable SMART Mini Jumper Clamps
- Universal Cable (black) with 8 different detachable tips to fit laptop-charging ports for various brands (Acer®, Dell™, HP®, Asus®, and more)
- Universal Cable (black) for all 12V Accessories (e.g. mobile DVD players)
- Universal USB Cable (white) with 8 different detachable tips to fit all 5V USB-chargeable electronics
- Home charger for wall charging that is compatible with 110V and 220V outlets
- Mobile charger for plugging into cigarette lighter socket

DBY-ACC56-25-02 .....\$209.99

**B. JUMP START HARNESS KIT  
BY ANTIGRAVITY BATTERIES®**

- Permanently affixes a 12" long jump start harness to your battery.
- Eliminates the need to carry jumper cables – just plug your Micro-Start™ directly to the cable lead.
- Comes with an SAE adaptor (fits most newer battery chargers) to charge your battery while stored.
- SAE adapter is also included which allows you to hook up a standard SAE-type charger to the Micro-Start™ harness. The adapter converts the Micro-Start™ harness (blue connector) down to an SAE connector so you can easily hook up your battery charger and eliminate the standard SAE harness you might have.

**NOTICE:** A standard SAE-type harness will NOT handle jump-starting – the wire gauge is much too thin and the wires will melt. The Micro-Start™ is intended for jump starting only through the jump start port. Never leave the Micro-Start™ connected to your vehicle's battery for longer than 30 seconds. Never use the Micro-Start™ in place of your regular battery. Never attempt to charge the Micro-Start™ directly from your battery through the jump start port – this could result in severe damage.

DBY-ACC56-24-98 .....\$26.99



A



B





A



B



C



D



E

### A. REPLACEMENT MINI JUMP START CLAMPS BY ANTIGRAVITY BATTERIES®

- Replacement for lost or damaged cables
- Compatible with the Micro-Start™ XP-1, XP-3, XP-5
- Clamps feature a built-in diode to prevent back-charge to the Micro-Start™ from the vehicle

**NOTICE:** Cables can be damaged when trying to jump start a vehicle that draws more current than the Micro-Start™ is capable of supplying - if this occurs regularly, you need to get a larger Micro-Start™. The Micro-Start™ is intended for jump starting only through the jump start port. Never leave the Micro-Start™ connected to your vehicle's battery for longer than 30 seconds. Never use the Micro-Start™ in place of your regular battery. Never attempt to charge the Micro-Start™ directly from your battery through the jump start port - this could result in severe damage.

DBY-ACC56-24-99 .....\$16.99

### B. 6-IN-1 RETRACTABLE USB BY ANTIGRAVITY BATTERIES®

The 6-in-1 Retractable USB by Antigravity Batteries® features:

- Saves space and easy to carry anywhere you go
- 30" long when fully extended and 4" when retracted
- Covers most of your USB device charging needs
- Charging tips include: Micro USB, Mini USB, Apple® 30-Pin and Lightning® (new 8-pin type) connectors, Samsung®, and Nokia®

DBY-ACC56-25-00 .....\$10.99

### C. BATTERY TENDER® WATERPROOF POWER TENDER PLUS

This waterproof battery charger is shock and vibration resistant, lightweight (less than 4 pounds), and compact. Designed for either portable operation or permanent mounting. Charges and maintains flooded and sealed batteries, including maintenance free, AGM, and lead acid batteries. The Float/ Maintenance function maintains batteries at proper storage voltage without the damaging effects that can be caused by trickle chargers.

SBT-CHGPT-ND-12.....\$134.49

### D. BATTERY TENDER® PLUS

The Battery Tender® Plus is a 1.25 amp battery charger designed to fully charge a battery and maintain it at proper storage voltage without the damaging effects caused by trickle chargers. Included is a quick connect ring terminal harness for hard to reach areas and alligator clips for an alternate connection.

ACC-CHGBT-TN-12 .....\$76.99

### E. BATTERY TENDER® WATERPROOF 800

This compact 800 battery charger has all the charge characteristics of its cousin, the Battery Tender® Junior. It incorporates highly efficient surface mount technology electronic components. The interior is completely encapsulated, protected from shock, vibration, and moisture by an electrically insulating, thermally conductive, flame retardant, synthetic epoxy resin compound. It's tough, affordable, and a strong, innovative battery charging solution. This charger is no larger than a standard computer mouse yet packs 800 milliamps of pure constant current charging power. Coupled with a brain (IC chip), the charger will constantly monitor, charge, and then maintain your battery - even while totally submersed under water! Perfect for all outdoor types of ATVs, watercraft, motorcycles, boats, or anywhere water is a threat. Charges 12V @ 800 mA.

SBT-BTWP8-00-11 .....\$57.49

ELECTRICAL

MISCELLANEOUS

RAMPS

STANDS &amp; MATS

STRAPS &amp; TIE DOWNS

ELECTRICAL

MISCELLANEOUS

RAMPS

STANDS & MATS

STRAPS & TIE DOWNS

**A. BATTERY TENDER® JUNIOR**

Lightweight and compact for the hard-to-fit spots. Fully charges and maintains battery at proper storage voltage.

Other features include:

- Temperature compensation
- Powder-coated aluminum chassis
- Charges as fast as 1.25-amp charger using only 0.75 amps
- Reverse-polarity protected
- Complete 2-step charging program
- Charges standard and AGM batteries
- Quick-connect harness and a 12-foot output cord

ACC-CHGJR-BT-12.....\$39.95



A

**B. BATTERY TENDER® SOLAR PANEL**

Solar panel with built-in Battery Tender® 3-step automatic microprocessor controller. 100% portable battery charging and maintenance. Perfect for storage space without power access! Battery Tender® solar panels are the only panels available with a built-in charge controller to prevent overcharging. Spark proof. 5-Watt version: 3 lbs. 13.25" x 16" x 0.875" 10-Watt version: 5.5 lbs. 26" x 16" x 0.875"

SBT-BTSOL-AR-11 (5-Watt) (Shown).....\$85.95

SBT-SOLAR-10-11 (10-Watt).....\$125.99

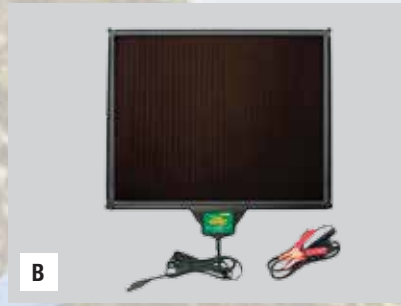

B



C

**C. BATTERY TENDER® RING TERMINAL HARNESS**

This Ring Terminal Harness can be used with multiple battery types and is compatible with any battery charger using a SAE-71 connector. Image is of the bulk container for dealer display (25 per jar). See your dealer for individual quantity and pricing.

SBT-0069J-25-11 .....\$170.99

**D. OPTIMATE® LITHIUM-IRON BATTERY CHARGER**

Lithium-iron (LiFePO<sub>4</sub>) batteries take a charge in a different way from lead/acid batteries. Attempting to use an automotive or motorcycle charger intended for lead/acid batteries can permanently damage a lithium-iron battery. The OptiMate® brand is a technology leader well known for high-quality battery chargers. That is why we are pleased to offer the OptiMate® Lithium charger specifically designed for LiFePO<sub>4</sub> batteries. This charger will safely test, charge, and maintain lithium-technology batteries, protecting your investment.

DBY-ACC51-70-02 .....\$129.99



D

**E. OPTIMATE® 1 BATTERY CHARGER**

Never have another dead battery! The OptiMate® 1 Charger can be left plugged into any vehicle's 12-volt battery all season long. Comes standard with clip type lead and weatherproof permanent adaptor for quick and easy connect/disconnect. LED's for power on, charging, and charged battery states. Comes with a 3 year warranty.

DBY-ACC51-70-11 .....\$39.99

**F. OPTIMATE® 4 BATTERY CHARGER**

A truly diagnostic 0.8 amp battery optimizer for 12V lead-acid batteries (sealed maintenance-free, gel, or filler caps). The microprocessor-controlled OptiMate® 4 is designed to save neglected batteries and features:

- Dual-stage "Recovery" and "Turbo Recovery" desulfating action
- Sealed waterproof enclosure is ideal for snowmobiles, watercraft, and golf cars
- Special cables and bushings for ultra-cold temperatures down to -40° F
- Includes wall mounts, and now shows current display, hourly testing with easy to identify results, plus 24/7 maintenance
- Recommended for all 12V lead-acid batteries up to 75Ah

DBY-ACC51-70-01 .....\$80.85



E

**G. OPTIMATE® BATTERY CHARGER CONNECTOR LEAD**

Premium quick connect permanent battery lead for power sport batteries, with weather protected connection system and cable.

DBY-ACC56-23-81 .....\$9.99



F



G



A

**A. OPTIMATE® 40" USB CHARGER**

Connecting the USB charger to your vehicle's battery allows you to charge a variety of 12V devices that use either a mini or micro USB connector.

- Low input (12.4V) auto-off with short circuit and overload protection
- Heavy-duty, weatherproof, fully sealed rubber connections
- Includes 40" SAE connector and two USB charging connectors

**NOTE:** Do not use for a long time with engine off to avoid draining vehicle battery.

Please Note: Price listed is for a dealer pack of 5. These are available as individually priced items from your local dealer.

DBY-ACC51-70-07 .....\$164.99

**B. OPTIMATE® 18" FUSED Y-SPLITTER**

Plug into a standard SAE-71 connector on your battery and operate two 12V accessories at the same time.

- Fused on both sides of the splitter
- Heavy-duty, weatherproof
- Fully sealed rubber connections

**NOTE:** Do not use for a long time with engine off to avoid draining vehicle battery.

Please Note: Dealer order quantity = 5 individual splitters, available as individual sale item from a Yamaha dealer.

DBY-ACC51-70-05 .....\$77.99



B

**C. OPTIMATE® CHARGE NOW! WARNING FLASHER**

This device will flash continuously if the battery voltage has fallen below the test level and has approximately 50% remaining.

- Great for long term storage if you don't have a charger connected to keep the battery charged
- Heavy-duty, weatherproof, fully sealed rubber connections

Please Note: Price listed is for a dealer pack of 5. These are available as individually priced items from your local dealer.

DBY-ACC51-70-08 (For Sealed Battery).....\$90.99

DBY-ACC51-70-09 (For Std. Wet Battery).....\$90.99



C

**D. OPTIMATE® 40" LED FLASHLIGHT WITH BATTERY STATUS**

Always have an emergency light while out for a ride! This powerful six-LED flashlight also checks battery status to determine if the vehicle's charging system is working properly.

- Great in the workshop to light up those hard-to-see places on your bike or vehicle
- Heavy-duty, weatherproof
- Fully sealed rubber connections

Please Note: Price listed is for a dealer pack of 5. These are available as individually priced items from your local dealer.

DBY-ACC51-70-06 .....\$118.99



D

**E. ADAPTOR BY OPTIMATE®**

Allows OptiMate® 4 and OptiMate® 3+ connection sets to hook up to connectors (white plastic) on the older OptiMate® III model.

ACC-OPTIM-3P-AD .....\$6.95



E

ELECTRICAL

MISCELLANEOUS

RAMPS

STANDS & MATS

STRAPS & TIE DOWNS

**A. 12V ACCESSORY PLUG AND RECEPTACLE KIT**

The 12V Accessory Plug and Receptacle Kit is corrosion-resistant and has marine-grade construction. The plug features an LED indicator light, patented moisture-resistant sealing ring, strain relief, and an internal 10A fuse. The receptacle includes a water-resistant sealing cap, and can be installed from the front using the included mounting plate, or from the rear using the locking ring. Also features a special locking system that holds the plug and receptacle tightly together.

12-Volt Power Plug Features:

- Moisture proof sealing ring
- Built-in LED power indicator light and 10A fuse
- Compatible with standard 12V receptacles
- 10 amp max rating

ATV-12VPK-00-KT (Full Kit) (Shown).....\$44.99

ATV-12VPC-00-RC (Receptacle) .....\$21.99

DBY-ACC56-00-85 (12V Accessory Plug).....\$17.99

**B. EXTENSION CORD**

These Extension Cords provide additional length between the charger's output and the battery. Compatible with OptiMate® battery chargers. They are not compatible with 6V Battery Tender® Plus or any other Battery Tender® products with white quick-disconnect plugs.

SBT-C0148-12-11 (12.5' Single Pack) (Shown).....\$11.45

SBT-P4148-12-11 (12.5' 4-Pack) .....\$38.99

SBT-C0148-25-11 (25' Single Pack) .....\$15.95

**C. FEMALE CIGARETTE ADAPTOR**

This Female Cigarette Adaptor with quick-disconnect adaptor is compatible with OptiMate® battery chargers to provide additional options. Not compatible with 6V Battery Tender® Plus or any other Battery Tender® products with white quick-disconnect plugs.

SBT-00698-00-11 .....\$11.99

**D. MALE CIGARETTE ADAPTOR**

This Male Cigarette Adaptor with black quick-disconnect adaptor is compatible with OptiMate® battery chargers. Not compatible with 6V Battery Tender® Plus or any other Battery Tender® products with white quick-disconnect plugs.

SBT-00695-00-11 .....\$9.99

**E. ALLIGATOR CLIPS**

This alligator clip (2-pin) accessory can be used with multiple batteries. Includes a black quick-disconnect adaptor and is compatible with OptiMate® battery chargers.

SBT-00694-00-11 .....\$9.45

**F. M22 EXHAUST PLUG BY MATRIX CONCEPTS™**

Durable silicone plug protects against water and other objects going into the exhaust system.

*Fits 2-stroke and 4-stroke models*

DBY-ACC50-50-43 (Black, Matrix branded).....\$7.95

DBY-ACC50-50-44 (Black, Yamaha branded) (Shown).....\$7.95



A



B



C



D



E



F



A



B

**A. YZ GRIP DONUTS**

Yamaha Grip Donuts are designed to help prevent blistering. Fits all off-road models.

*Fits all Off-road Motorcycles*

**GYT-5XD22-00-00** .....\$6.95

**B. YAMAHA FACTORY RACING CLAMP COVER**

Printed on scratch-resistant 15-mil vinyl, featuring the Factory Racing logo. 10" long.

*Fits all Off-road Motorcycles with 1-1/8" handlebars*

**GYT-5XC25-18-BL (Blue)** .....\$20.99



C



D

**C. GYTR® CROSSBAR PAD**

Designed for handlebars with crossbar. Printed on scratch resistant, 15-mil vinyl featuring the Yamaha logo. 11" long.

*Fits all Off-road Motorcycles with 7/8" handlebars*

**GYT-CROSS-BR-02 (Blue)** .....\$11.95

**D. YAMAHA FACTORY RACING MINI CROSSBAR PAD**

Printed on scratch resistant, 15-mil vinyl, featuring the Factory Racing logo. 7.25" long.

*Fits all Off-road Motorcycles with 7/8" handlebars*

**GYT-5HP25-78-BL (Blue)** .....\$14.99



E

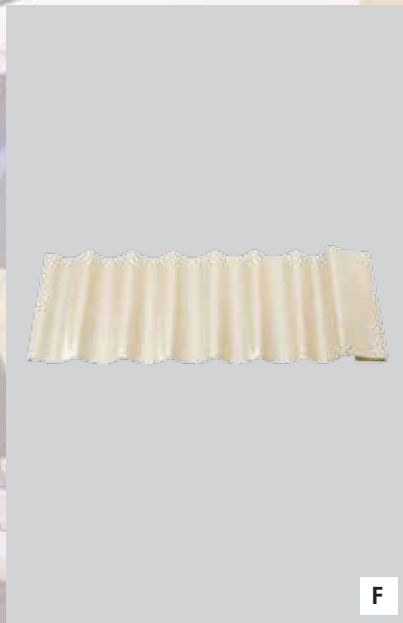

F

**E. M28 OIL DRAIN CONTAINER BY MATRIX CONCEPTS™**

The M28 Oil Drain Container by Matrix Concepts™ is a 1-gallon used oil storage container. This container is designed with a built in drain pan.

**DBY-ACC50-50-41 (Matrix branded)** .....\$19.95

**DBY-ACC50-50-42 (Yamaha branded) (Shown)** .....\$19.95

**F. YAMAHA CLEAR GUARD**

Protect high-wear areas on your bike using this thick 12-mil vinyl clear guard. Cut to fit from a generous 12" x 44" sheet.

*Useable on all models*

**ABA-CLEAR-GA-RD (Clear)** .....\$15.95

**G. NEW! MOTORCYCLE COVER**

Keep your dirtbike protected from dust at the track or in your garage with this Yamaha cover.

- Traditional Yamaha racing blue color featuring the GYTR, Yamalube and bLU cRU logos
- Lightweight material that can be quickly rolled up into the convenient attached storage bag
- Water resistant
- Equipped with a drawstring at the bottom to keep the cover in place

**NOTE:** Recommended for storage use only; not for trailering or transport

*Fits all YZ & WR models except YZ85*

**1SL-F81A0-V0-00 (Blue)** .....\$69.99

**GYT-OSS56-32-28 (Black)** .....\$41.49



G

ELECTRICAL

MISCELLANEOUS

RAMPS

STANDS & MATS

STRAPS & TIE DOWNS

ELECTRICAL

MISCELLANEOUS

RAMPS

STANDS & MATS

STRAPS & TIE DOWNS

**A. ARCHED RAMP BY PRO-WHEEL®**

The Arched Ramp by Pro-Wheel® features an arched design that provides more ground clearance than straight ramps. Aluminum construction optimizes both strength and weight. Two ramps required for use with ATVs and Side-by-Sides. 750 lb. weight capacity per ramp. Dimensions: 12" width, 88" length.

**NOTE:** Do not exceed maximum load capacity for ramp. Ramp must be secured with straps before use. Use ramp on stable and level surface only. Read all warning labels on ramp before use.

**ABA-OSS58-40-40** .....\$134.99

**B. ARCHED FOLDING RAMP BY PRO-WHEEL®**

The Arched Folding Ramp by Pro-Wheel® has an arched design provides more ground clearance than straight ramps. Convenient folding design for compact storage and transport. Aluminum construction optimizes both strength and weight. Two ramps required for use with ATVs and Side-by-Sides. 750 lb. weight capacity per ramp. Dimensions: 12" width, 84" length (folded - 12" x 48").

**NOTE:** Do not exceed maximum load capacity for ramp. Ramp must be secured with straps before use. Use ramp on stable and level surface only. Read all warning labels on ramp before use.

**ABA-OSS58-40-39** .....\$149.99

**C. FOLDING RAMP BY PRO-WHEEL®**

This 7' Folding Ramp by Pro-Wheel® has a convenient folding design which allows for compact storage and easy transport. Aluminum construction optimizes both strength and weight. 600 lb. weight capacity. Dimensions: 9" width, 88" length (folded - 9" x 44").

**NOTE:** Do not exceed maximum load capacity for ramp. Ramp must be secured with straps before use. Use ramp on stable and level surface only. Read all warning labels on ramp before use.

**ABA-OSS58-40-38** .....\$133.99

**D. A7 ALUMINUM RAMP BY MATRIX CONCEPTS™**

The A7 Aluminum Ramp by Matrix Concepts™ is a strong 6063 aircraft aluminum folding loading ramp featuring the Yamaha logo. Measures 6.5'.

**DBY-ACC56-34-60** (6.5', Black).....\$169.95

**E. FOLDING LOADING RAMPS BY MATRIX CONCEPTS™**

The Folding Loading Ramps are constructed of ABS, glass filled, injection-molded plastic and strengthened with 6061-T6 aluminum-reinforced inner rails that rate the ramp at over 500 lb. Design includes our exclusive "center traction ribbed beam design" for easy non-slip loading. Self-lubricating, folding hinge with "lifetime replacement warranty" against bending or breaking. Ramp is extremely lightweight, only 11 lb. Hinged, replaceable lower plastic feet work at any angle. Center handle allows for easy handling and folds in half for easy transportation and storage. Replaceable soft rubber bottom tongue plate. Eliminates excess sliding when loading. Exclusive five year limited warranty against bending or breaking.

**GYT-OSS56-32-20** (6', Black) (Shown) .....\$141.49

**GYT-OSS56-32-22** (8', Black).....\$151.49

**GYT-OSS56-32-23** (8', White).....\$151.49

**F. LOADING RAMP BY MATRIX CONCEPTS™**

The Loading Ramps by Matrix Concepts™ are constructed of ABS, glass filled, injection-molded plastic and strengthened with 6061-T6 aluminum-reinforced inner rails that rate the ramp at over 500 lb. Design includes our exclusive "center traction ribbed beam design" for easy non-slip loading. Ramp is extremely lightweight, only 9 lb. Hinged, replaceable lower plastic feet work at any angle. Center handle allows for easy handling and folds in half for easy transportation and storage. Replaceable soft rubber bottom tongue plate. Eliminates excess sliding when loading. Exclusive five year limited warranty against bending or breaking.

**GYT-OSS56-32-46** (6', Blue) .....\$121.49

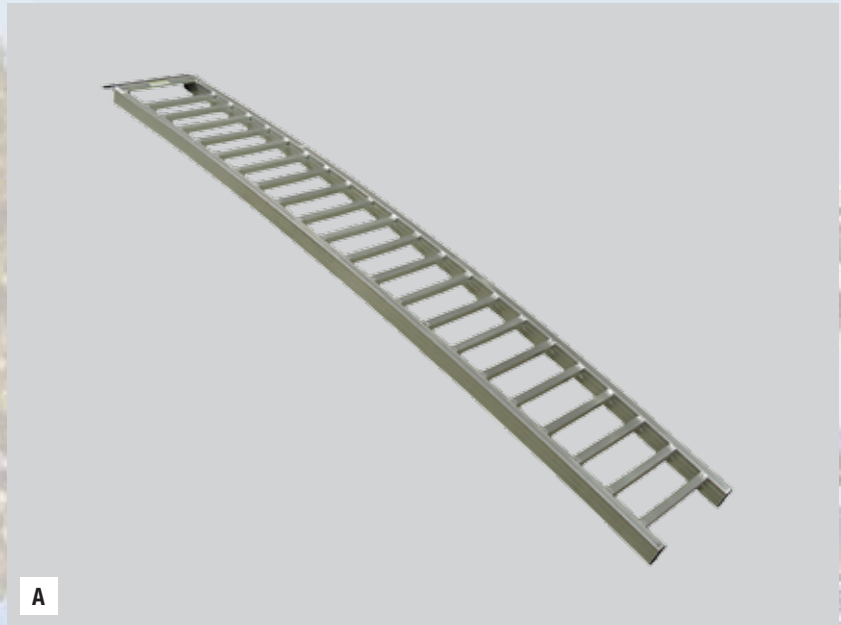

A



B



C



D



E



F

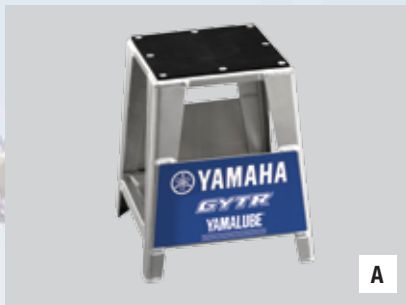

A



B

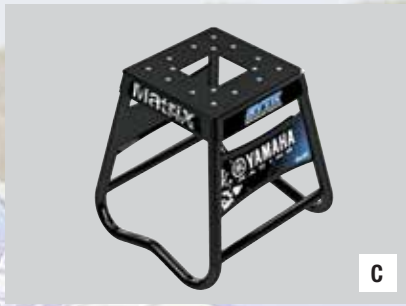

C



D



E

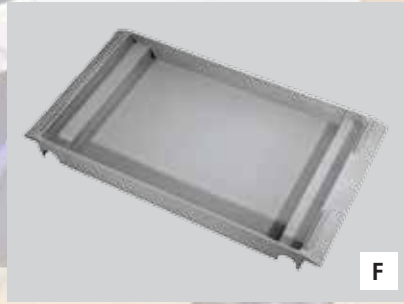

F



G



H

**A. GYTR® PANEL STAND**

The GYTR Panel Stand is made of strong aluminum. This stand features a rubber top pad to support and steady the bike during maintenance or storage. A built-in tool tray keeps tools and parts close to the bike. Yamaha logo display panels.

GYT-YZRWK-ST-00 .....\$101.95

**B. MOTO LIFT STAND BY G2 ERGONOMICS®**

This stand from G2 Ergonomics® features double-stem tubular construction and is far stronger than aluminum lift stands. This stand is designed to be carried by the handle unlike other stands on the market. The large handle makes it easy to lift and lower the motorcycle.

GYT-OSS56-31-84 (Black) .....\$59.99

**C. A2 ALUMINUM STAND BY MATRIX CONCEPTS™**

The A2 Aluminum Stand by Matrix Concepts™ is super lightweight and strong 6063 aircraft aluminum bike stand featuring the Yamaha logo.

DBY-ACC56-34-58 (Black).....\$139.95

**D. C1 CARBON STEEL STAND BY MATRIX CONCEPTS™**

The C1 Carbon Steel Stand by Matrix Concepts™ is a strong powder coated 1010 carbon steel bike stand.

DBY-ACC56-34-54 (Black, Matrix Branded) .....\$59.95  
 DBY-ACC56-34-55 (Red, Matrix Branded) (Shown) .....\$59.95  
 DBY-ACC56-34-56 (Black, Yamaha Branded).....\$59.95  
 DBY-ACC56-34-57 (Blue, Yamaha Branded).....\$59.95

**E. M64 ELITE STAND BY MATRIX CONCEPTS™**

Replaceable PVC "rubber traction top" with easy to use steel fasteners and rectangular access slot for easy oil draining. Constructed of 100% "I Beam" ABS glass filled plastic and weighing in at only 6 lb. The M2 WORX Stand is very lightweight, strong, and rated at 500+ lb. Two-year limited warranty against bending or breaking.

*For use with YZ & WR models*

DBY-ACC56-34-53 (Black, Matrix branded).....\$119.95  
 GYT-OSS56-32-16 (Black, Yamaha branded) (Shown) .....\$122.49  
 GYT-OSS56-32-15 (Blue, Yamaha branded).....\$122.49  
 GYT-OSS56-32-17 (Silver, Yamaha branded) .....\$113.49

**F. M2 WORX STAND TRAY BY MATRIX CONCEPTS™**

Tray works with the M2 WORX Stand or can be used by itself on the floor or on the work bench to hold parts and tools. Also works great as an oil tub/ bath for soaking your clutch plates. Side handles make it easy to put in place and remove from the M2 WORX Stand. 100% ABS plastic construction makes it lightweight and very strong. Can be easily cleaned with household cleaning products. Exclusive five year limited warranty against breaking.

GYT-OSS56-32-19 (Silver) .....\$20.95

**G. GYTR® WORK PAD**

Work pad goes under and around your bike's work stand. It's padded so it is soft on your feet and knees while you prep your bike. You can use it as a changing pad so you don't get dirty suiting up. Now with durable center patch sewn in for placement of a work stand (as shown here) and to help keep the mat in place while in use.

GYT-STAND-PD-BL (Blue).....\$59.99

**H. M5 STAND MAT BY MATRIX CONCEPTS™**

The M5 Stand Mat by Matrix Concepts™ is great for use in the garage, shop, back of your truck or at the track.

This mat is used by top factory and satellite teams and features:

- Tough, colorfast, non-fade PVC 2' x 2'
- Gas, oil, and contact cleaner-resistant
- Keeps parts clean and out of the dirt
- Parts lands on a soft surface if dropped
- Prevents scratching your truck bed
- Rolls up for easy transport
- Includes netted drawstring carry bag

GYT-OSS56-32-28 (Black) .....\$41.49

ELECTRICAL

MISCELLANEOUS

RAMPS

STANDS & MATS

STRAPS & TIE DOWNS

ELECTRICAL

MISCELLANEOUS

RAMPS

STANDS & MATS

STRAPS & TIE DOWNS

**A. NEW! YAMALUBE®/ GYTR® RACE PIT MAT BY MATRIX**

The Race Pit Mat is perfect for the garage, outdoors, or in the pits at the track to provide superior footing.

- Extra thick 3' x 7' 2mm PVC rubber
- Rubber and screen printing are both gas and oil resistant
- Includes netted bag and mat rolls up for easy transport

ACC-YLRCE-PT-MT .....\$109.95



**B. YAMAHA RATCHETING TIE DOWNS**

The Yamaha Ratcheting Tie Downs are 1" x 10" with 1" rubber handle ratchet. Straps are rated for 400 lb., working and 1200 lb. break strength. (Sold in pairs).

ACC-OSS58-40-29 (Black) (Shown) .....\$20.95

ACC-OSS58-40-30 (Blue).....\$20.95

**C. YAMAHA CAM BUCKLE TIE DOWNS**

The Yamaha Cam Buckle Tie Downs are 1" x 6' with 1" cam lock buckle. Straps are rated for 400 lb. working and 1200 lb. break strength. (Sold in pairs).

ACC-OSS58-40-27 (Black) (Shown) .....\$19.95

ACC-OSS58-40-28 (Blue).....\$19.95

**D. RAT PAK TIE DOWNS BY ANCRA®**

The Rat Pak Tie Downs are ideal when greater tensioning power is needed. It incorporates Ancra's® 1" ratchet buckle, nylon webbing, vinyl coated hooks with an overall length of 5-1/2'. Assembly strength is 1200 lb. with a 400 lb. working load limit. (Sold in pairs).

DBY-ACC58-40-52 (Red) .....\$40.49

DBY-ACC58-40-53 (Black).....\$40.49

A

**E. INTEGRA® CLASSIC TIE DOWNS BY ANCRA®**

The Integra® Classic tie down incorporates a soft hook extension to the fixed end of the tie down to loop around larger diameter handlebars, frame member, triple tree clamp or other structural point. Overall length is 69", and made with abrasion-resistant nylon webbing and vinyl-coated hooks. Assembly strength of 1200 lb. with a 400 lb. working load limit. (Sold in pairs).

DBY-ACC58-40-49 (Red) .....\$40.95

DBY-ACC58-40-50 (Black).....\$40.95



B



C

**F. INTEGRA® RAT PAK TIE DOWNS BY ANCRA®**

The Integra® Rat Pak is the same high-quality tie down as the Rat Pak, except the Integra® has a built-in soft hook on the fixed end for looping around handlebars, frame tubes, triple-tree clamps, and other structural members. It's constructed of abrasion-resistant nylon webbing with two vinyl-coated hooks. Overall length is 5-1/2'. Assembly strength of 1200 lb. with a 400 lb. working load limit. (Sold in pairs).

DBY-ACC58-40-54 (Red) .....\$43.49

DBY-ACC58-40-55 (Black).....\$43.49



D



E

**G. ORIGINAL TIE DOWNS BY ANCRA®**

The Original Tie Downs by Ancra® set the standard with its features that includes:

- 5-1/2' long
- Constructed of abrasion heavy-duty 1" cam buckle
- Zinc cam and pressure plate to reduce webbing abrasion
- Vinyl-coated hooks
- 1200 lb. assembly strength with 400 lb. working load limit
- Sold in pairs

DBY-ACC58-40-56 (Red) .....\$35.95

DBY-ACC58-40-57 (Black).....\$35.95

DBY-ACC58-40-58 (Blue) .....\$35.95



F



G





A

**A. M1 1.0" WORX TIE DOWN BY MATRIX CONCEPTS™**

The M1 1.0" WORX Tie Down by Matrix Concepts™ is a premium tie down set with top soft loop hook, bottom swivel carabiner and Yamaha graphics.

Other features include:

- Overall length is 69" x 1" wide
- Made from abrasion-resistant nylon webbing
- Double-stitched square/cross with heavy-duty nylon thread
- Soft hoop top with bottom rubber coated "S" hook incorporated into design to protect your handlebars
- Custom spring loaded lock-on "swivel carabiner" bottom hook for secure connection
- Heavy-duty steel "cam-lock" with tough steel spring for a secure lock
- Assembly strength is 1,200 lb. and a 400 lb. load limit

GYT-OSS56-32-36 (Blue) .....	\$36.99
GYT-OSS56-32-37 (Black) .....	\$36.99
GYT-OSS56-32-38 (Red) .....	\$39.99



B

**B. M1 1.5" PHATTY TIE DOWN BY MATRIX CONCEPTS™**

The M1 1.5" Phatty Tie Down by Matrix Concepts™ is a premium tie down set with top soft loop hook, bottom swivel carabiner and Yamaha graphics.

Other features include:

- Overall length is 69" x 1.5" wide
- Made from abrasion-resistant nylon webbing
- Double-stitched with square/cross with heavy-duty nylon thread
- Top soft loop extension with rubber coated "S" hook incorporated into design to protect your handlebars
- Custom spring loaded lock-on "swivel carabiner" bottom hook for secure connection
- Heavy-duty steel "cam-lock" with tough steel spring for a secure lock
- Assembly strength is 1,400 lb. and a 500 lb. load limit

GYT-OSS56-32-33 (Blue) .....	\$49.99
GYT-OSS56-32-34 (Black) .....	\$49.99
GYT-OSS56-32-35 (Red) .....	\$49.99



C

**C. M1 UTILITY STRAPS BY MATRIX CONCEPTS™**

These wheel straps are perfect for trailers to hold your wheels in place and for general multi-purpose usage. The straps are made from abrasion-resistant nylon webbing and all stitching is double-stitched square/cross with heavy-duty nylon thread. A heavy-duty steel cam-lock with tough steel spring provides a secure lock to keep things tight. Features Yamaha and Matrix™ graphics. Sold in pairs. Utility straps measure 40" long x 1" wide and the wheel straps measure 30" long x 1" wide.

GYT-OSS56-32-39 (Blue) .....	\$13.95
------------------------------	---------



D

**D. M1 WHEEL STRAPS BY MATRIX CONCEPTS™**

These wheel straps are perfect for trailers to hold your wheels in place and for general multi-purpose usage. The straps are made from abrasion-resistant nylon webbing and all stitching is double-stitched square/cross with heavy-duty nylon thread. A heavy-duty steel cam-lock with tough steel spring provides a secure lock to keep things tight. Features Yamaha and Matrix™ graphics. Sold in pairs. Utility straps measure 40" long x 1" wide and the wheel straps measure 30" long x 1" wide.

GYT-OSS56-32-40 (Blue) .....	\$13.49
------------------------------	---------



E

**E. MOTO-GATE® BY SETWEAR®**

The Moto-Gate® by Setwear® is an universal expandable tailgate. Durable nylon mesh with rubber coated tie down hooks. Keeps tools, gear, bikes, ATVs in back of truck. Fully adjustable. Easy on, easy off. Fits most models of trucks. Full net set is rated at 1 ton and a breaking load of 3 tons; hooks are rated at 1 ton.

GYT-OSS58-40-01 (Black) .....	\$64.49
-------------------------------	---------

ELECTRICAL

MISCELLANEOUS

RAMPS

STANDS & MATS

STRAPS & TIE DOWNS





# 2017 QUICK-REFERENCE GUIDE FOR: YAMALUBE®/ YAMAHA GENUINE PARTS



# OFF-ROAD MCY.

# OFF-ROAD MCY.

## OILS & FILTERS

Model Year	Model	Oil Capacity: Oil & Filter	Engine Oil Grade	Engine Oil Filter	Transmission Oil Capacity	Transmission Oil Grade
2000	2017	PW50	N/A	N/A	0.31 US QT (0.3L)	10W40
1983	2006	PW80	N/A	N/A	0.69 US QT (0.65L)	10W40
2000	2000	RT100	0.58 US QT (0.55L)	A*	N/A	N/A
2008	2017	TT-R110	0.85 US QT (0.8L)	A*	N/A	N/A
2000	2004	TT-R125	1.06 US QT (1.0L)	A*	N/A	N/A
2003	2009	TT-R125E	1.06 US QT (1.0L)	A*	N/A	N/A
2000	2008	TT-R125L	1.06 US QT (1.0L)	A*	N/A	N/A
2003	2017	TT-R125LE	1.06 US QT (1.0L)	A*	N/A	N/A
2000	2004	TT-R225	1.16 US QT (1.1L)	A*	5H0-13440-09-00	N/A
2005	2017	TT-R230	1.16 US QT (1.1L)	A*	5H0-13440-09-00	N/A
1999	2006	TT-R250	1.16 US QT (1.1L)	A*	1UY-13440-02-00	N/A
2006	2017	TT-R50	0.85 US QT (0.8L)	A*	N/A	N/A
2000	2007	TT-R90	0.85 US QT (0.8L)	A*	N/A	N/A
1995	1997	WR250	N/A	N/A	0.79 US QT (0.75L)	ACC-TRANS-PL-US
2001	2002	WR250F	1.69 US QT (1.6L)	A*	N/A	N/A
2003	2005	WR250F	1.37 US QT (1.3L)	A*	N/A	N/A
2006	2012	WR250F	1.27 US QT (1.2L)	A*	N/A	N/A
2013	2013	WR250F	1.48 US QT (1.4L)	A*	N/A	N/A
2015	2017	WR250F	0.90 US QT (0.85L)	A*	N/A	N/A
1998	2000	WR400	1.69 US QT (1.6L)	A*	N/A	N/A
2001	2002	WR426	1.69 US QT (1.6L)	A*	N/A	N/A
2003	2003	WR426	1.48 US QT (1.4L)	A*	N/A	N/A
2003	2004	WR450F	1.16 US QT (1.1L)	A*	N/A	N/A
2005	2005	WR450F	1.16 US QT (1.1L)	B*	N/A	N/A
2006	2014	WR450F	1.06 US QT (1.0L)	A*	N/A	N/A
2015	2017	WR450F	0.73 US QT (0.69L)	A*	N/A	N/A

\*A = 10W40 or 10W50, 20W50 or 15W50 OVER 100°F

\*B = 20W50 or 15W50, 10W40 or 10W50 BELOW 40°F

# OFF-ROAD MCV.

# OFF-ROAD MCV.

## OILS & FILTERS

Model Year	Model	Oil Capacity: Oil & Filter	Engine Oil Grade	Engine Oil Filter	Transmission Oil Capacity	Transmission Oil Grade
1995	2001	YZ80	N/A	2S	N/A	ACC-TRANS-PL-US
2002	2015	YZ85	N/A	2R	0.53 US QT (0.5L)	ACC-TRANS-PL-US
2016	2017	YZ85	N/A	2R	0.53 US QT (0.5L)	ACC-TRANS-PL-US
1995	2002	YZ125	N/A	2R (Premix 30:1)	0.54 US QT (0.51L)	ACC-TRANS-PL-US
2003	2003	YZ125	N/A	2R (Premix 30:1)	0.69 US QT (0.65L)	ACC-TRANS-PL-US
2004	2017	YZ125	N/A	2R (Premix 30:1)	0.69 US QT (0.65L)	ACC-TRANS-PL-US
1995	2016	YZ250	N/A	2R (Premix 30:1)	0.70 US QT (0.66L)	ACC-TRANS-PL-US
2017	2017	YZ250	N/A	2R (Premix 30:1)	0.79 US QT (0.75L)	ACC-TRANS-PL-US
2001	2002	YZ250F	1.69 US QT (1.6L)	B*	0.74 US QT (0.70L)	ACC-TRANS-PL-US
2003	2003	YZ250F	1.16 US QT (1.1L)	B*	N/A	N/A
2004	2004	YZ250F	1.27 US QT (1.2L)	B*	N/A	N/A
2005	2005	YZ250F	1.16 US QT (1.1L)	B*	N/A	N/A
2006	2006	YZ250F	1.32 US QT (1.25L)	B*	N/A	N/A
2007	2009	YZ250F	1.22 US QT (1.15L)	A*	N/A	N/A
2010	2013	YZ250F	1.11 US QT (1.05L)	A*	N/A	N/A
2014	2017	YZ250F	0.77 US QT (0.73L)	A*	N/A	N/A
2015	2016	YZ250FX	0.77 US QT (0.73L)	A*	N/A	N/A
2017	2017	YZ250FX	0.90 US QT (0.85L)	A*	N/A	N/A
2016	2016	YZ250X	N/A	2R (Premix 30:1)	N/A	N/A
2017	2017	YZ250X	N/A	2R (Premix 30:1)	0.79 US QT (0.75L)	ACC-TRANS-PL-US
1999	1999	YZ400F	1.69 US QT (1.6L)	A*	0.74 US QT (0.70L)	ACC-TRANS-PL-US
2000	2003	YZ426F	1.69 US QT (1.6L)	A*	N/A	N/A
2003	2003	YZ450F	1.16 US QT (1.1L)	A*	N/A	N/A
2004	2005	YZ450F	1.06 US QT (1.0L)	B*	N/A	N/A
2006	2013	YZ450F	1.06 US QT (1.0L)	A*	N/A	N/A
2014	2017	YZ450F	0.73 US QT (0.69L)	A*	N/A	N/A
2016	2017	YZ450FX	0.73 US QT (0.69L)	A*	N/A	N/A

\*A = 10W40 or 10W50, 20W50 or 15W50 OVER 100°F  
\*B = 20W50 or 15W50, 10W40 or 10W50 BELOW 40°F

# OFF-ROAD MCY.

# OFF-ROAD MCY.

## YAMAHA GENUINE PARTS

Model Year	Model	Battery	Spark Plug	Air Cleaner	Front Brake Pad (Qty)	Rear Brake Pad (Qty)	Front Brake Shoe (Qty)	Rear Brake Shoe (Qty)	Drive Chain	Front Sprocket	Rear Sprocket
2000	PW50	N/A	BP4-HS000-00-00	4X4-14451-00-00	N/A	N/A	3PT-W253A-10-00 (1)	3PT-W253A-10-00 (1)	N/A	N/A	N/A
1983	PW80	N/A	BP6-HS000-00-00	21W-14451-00-00	N/A	N/A	18A-W2534-00-00 (1)	18A-W2534-00-00 (1)	94580-52084-00	93812-15063-00	4BC-25432-50-00
1992	PW80	N/A	BP6-HS000-00-00	21W-14451-00-00	N/A	N/A	3EC-W253A-00-00 (1)	4BE-W253E-00-00 (1)	94580-52084-00	93812-15063-00	4BC-25432-50-00
2000	PW80	N/A	BP6-HS000-00-00	21W-14451-00-00	N/A	N/A	3EC-W253A-00-00 (1)	4BE-W253E-00-00 (1)	94580-52084-00	93812-15063-00	21W-25432-10-00
2004	PW80	N/A	BP6-HS000-00-00	4BC-14451-00-00	N/A	N/A	3EC-W253A-00-00 (1)	4BE-W253E-00-00 (1)	94561-66084-00	93812-15063-00	21W-25432-10-00
2006	PW80	N/A	BP6-HS000-00-00	4BC-14451-00-00	N/A	N/A	3EC-W253A-00-00 (1)	4BE-W253E-00-00 (1)	94561-66084-00	93812-15063-00	4BC-25432-50-00
2000	RT100	N/A	BR7-ES000-00-00	1T9-14450-00-00	N/A	N/A	4BE-W253E-00-00 (1)	4BE-W253E-00-00 (1)	9Y580-52103-00	93812-14035-00	2U2-25448-11-00
2008	TT-R110	GT4-B5000-00-00	CR6-HSA00-00-00	5B6-14451-00-00	N/A	N/A	5B6-W253A-00-00 (1)	4BE-W253E-00-00 (1)	9Y580-52089-00	93812-14814-00	5A7-25435-01-00
2000	TT-R125	N/A	CR7-HSA00-00-00	5HP-14450-00-00	N/A	N/A	4KN-W253E-11-00 (1)	4KN-W253E-11-00 (1)	9Y581-97121-00	93822-13213-00	5FC-25449-20-00
2002	TT-R125	N/A	CR7-HSA00-00-00	5HP-14450-00-00	N/A	N/A	4KN-W253E-11-00 (1)	4KN-W253E-11-00 (1)	9Y581-97121-00	93822-13213-00	5HP-25449-20-00
2003	TT-R125E	GTX-4LBS0-00-00	CR7-HSA00-00-00	5HP-14450-00-00	N/A	N/A	4KN-W253E-11-00 (1)	4KN-W253E-11-00 (1)	9Y581-97121-00	93822-13213-00	5HP-25449-20-00
2007	TT-R125E	GTX-4LBS0-00-00	CR7-HSA00-00-00	5HP-14450-00-00	N/A	N/A	4KN-W253E-11-00 (1)	4KN-W253E-11-00 (1)	9Y581-97121-00	93822-13213-00	1B2-F5449-21-00
2008	TT-R125E	GTX-4LBS0-00-00	CR7-HSA00-00-00	5HP-14450-00-00	N/A	N/A	4KN-W253E-11-00 (1)	4KN-W253E-11-00 (1)	9Y581-97121-00	93822-13213-00	1B2-F5449-21-00
2000	TT-R125L	N/A	CR7-HSA00-00-00	5HP-14450-00-00	3UN-W0045-00-00 (1)	N/A	N/A	4KN-W253E-11-00 (1)	9Y581-97121-00	93822-13213-00	5FC-25449-20-00
2002	TT-R125L	N/A	CR7-HSA00-00-00	5HP-14450-00-00	3UN-W0045-00-00 (1)	N/A	N/A	4KN-W253E-11-00 (1)	9Y581-97121-00	93822-13213-00	5HP-25449-20-00
2007	TT-R125L	N/A	CR7-HSA00-00-00	5HP-14450-00-00	3UN-W0045-00-00 (1)	N/A	N/A	4KN-W253E-11-00 (1)	9Y581-97121-00	93822-13213-00	1B2-F5449-21-00
2008	TT-R125L	N/A	CR7-HSA00-00-00	5HP-14450-00-00	3UN-W0045-00-00 (1)	N/A	N/A	4KN-W253E-11-00 (1)	9Y581-97121-00	93822-13213-00	1B2-F5449-21-00
2003	TT-R125LE	GTX-4LBS0-00-00	CR7-HSA00-00-00	5HP-14450-00-00	3UN-W0045-00-00 (1)	N/A	N/A	4KN-W253E-11-00 (1)	9Y581-97121-00	93822-13213-00	5HP-25449-20-00
2007	TT-R125LE	GTX-4LBS0-00-00	CR7-HSA00-00-00	5HP-14450-00-00	3UN-W0045-00-00 (1)	N/A	N/A	4KN-W253E-11-00 (1)	9Y581-97121-00	93822-13213-00	1B2-F5449-21-00
2008	TT-R125LE	GTX-4LBS0-00-00	CR7-HSA00-00-00	5HP-14450-00-00	3UN-W0045-00-00 (1)	N/A	N/A	4KN-W253E-11-00 (1)	9Y581-97121-00	93822-13213-00	1B2-F5449-21-00
2014	TT-R125LE	GTX-4LBS0-00-00	CR7-HSA00-00-00	5HP-14450-00-00	3UN-W0045-00-00 (1)	N/A	N/A	4KN-W253E-11-00 (1)	9Y581-97121-00	93822-13213-00	1B2-F5449-21-00
2015	TT-R125LE	GTX-4LBS0-00-00	CR7-HSA00-00-00	5HP-14450-00-00	3UN-W0045-00-00 (1)	N/A	N/A	4KN-W253E-11-00 (1)	9Y581-97121-00	93822-13213-00	1B2-F5449-21-00
2000	TT-R225	YB7-BB000-00-00	DR8-EA000-00-00	1KH-14451-00-00	38N-W0045-01-00 (1)	N/A	N/A	3KG-W253E-00-00 (1)	9Y581-33127-00	4VW-E7461-10-00	5FG-F5458-01-00
2005	TT-R230	YTX-5LBS0-00-00	DR8-EA000-00-00	94700-00822-00	5RM-F5805-20-00 (1)	N/A	N/A	3FA-W253A-00-00 (1)	9Y581-47105-00	93832-13164-00	106-F5449-22-00
2015	TT-R230	YTX-5LBS0-00-00	DR8-EA000-00-00	106-14451-00-00	5RM-F5805-20-00 (1)	N/A	N/A	5HH-F5330-00-00 (1)	9Y581-47105-00	93832-13164-00	106-F5449-22-00
1999	TT-R250	G17-B4000-00-00	CR9-E0000-00-00	11LN-14451-00-00	5GF-W0045-00-00 (1)	N/A	N/A	N/A	9Y581-38109-00	9383R-13211-00	26A-25452-51-00
2006	TT-R50	GT4-B5000-00-00	CR7-HSA00-00-00	1P6-E4451-00-00	N/A	N/A	1P6-W253A-00-00 (1)	1P6-W253A-00-00 (1)	94568-A1080-00	93812-13812-00	1P6-F5437-11-00
2000	TT-R90	N/A	CR6-HSA00-00-00	5HN-14451-00-00	N/A	N/A	3EC-W253A-00-00 (1)	4BE-W253E-00-00 (1)	9Y561-52085-00	93812-14035-00	5A7-25435-01-00
2003	TT-R90	GT4-B5000-00-00	CR6-HSA00-00-00	5HN-14451-00-00	N/A	N/A	3EC-W253A-00-00 (1)	4BE-W253E-00-00 (1)	9Y561-52085-00	93812-14035-00	5A7-25435-01-00

# OFF-ROAD MCY.

# OFF-ROAD MCY.

YAMAHA GENUINE PARTS										
Model Year	Model	Front Fork Seal Kit	Fork Oil Seal	Fork Dust Seal	Bearing Kit - Shock Linkage	Bearing Kit - Swing Arm Pivot	Gasket Kit - Top End	Gasket Kit - Bottom End	Clutch Kit	
2000	2017	PW50	N/A	N/A	N/A	N/A	N/A	N/A	N/A	N/A
1983	1991	PW80	1RY-23145-00-00	N/A	N/A	N/A	N/A	N/A	N/A	N/A
1992	1999	PW80	1RY-23145-00-00	N/A	N/A	N/A	N/A	N/A	N/A	N/A
2000	2003	PW80	1RY-23145-00-00	N/A	N/A	N/A	N/A	N/A	N/A	N/A
2004	2005	PW80	1RY-23145-00-00	N/A	N/A	N/A	N/A	N/A	N/A	N/A
2006	2006	PW80	1RY-23145-00-00	N/A	N/A	N/A	N/A	N/A	N/A	N/A
2000	2000	RT100	93110-27010-00	462-23144-02-00	N/A	N/A	N/A	N/A	N/A	N/A
2008	2016	TT-R110	5B6-23145-00-00	5B6-23144-00-00	N/A	N/A	N/A	N/A	N/A	N/A
2000	2001	TT-R125	33J-23145-00-00	N/A	N/A	N/A	N/A	N/A	N/A	N/A
2002	2004	TT-R125	33J-23145-00-00	N/A	N/A	N/A	N/A	N/A	N/A	N/A
2003	2006	TT-R125E	33J-23145-00-00	N/A	N/A	N/A	N/A	N/A	N/A	N/A
2007	2007	TT-R125E	33J-23145-00-00	N/A	N/A	N/A	N/A	N/A	N/A	N/A
2008	2009	TT-R125E	5B6-23145-00-00	N/A	N/A	N/A	N/A	N/A	N/A	N/A
2000	2001	TT-R125L	33J-23145-00-00	N/A	N/A	N/A	N/A	N/A	N/A	N/A
2002	2006	TT-R125L	33J-23145-00-00	N/A	N/A	N/A	N/A	N/A	N/A	N/A
2007	2007	TT-R125L	33J-23145-00-00	N/A	N/A	N/A	N/A	N/A	N/A	N/A
2008	2008	TT-R125L	5B6-23145-00-00	N/A	N/A	N/A	N/A	N/A	N/A	N/A
2003	2006	TT-R125LE	33J-23145-00-00	N/A	N/A	N/A	N/A	N/A	N/A	N/A
2007	2007	TT-R125LE	33J-23145-00-00	N/A	N/A	N/A	N/A	N/A	N/A	N/A
2008	2014	TT-R125LE	5B6-23145-00-00	N/A	N/A	N/A	N/A	N/A	N/A	N/A
2015	2017	TT-R125LE	5B6-23145-00-00	N/A	N/A	N/A	N/A	N/A	N/A	N/A
2000	2004	TT-R225	1KH-23145-00-00	1KH-23144-00-00	N/A	N/A	N/A	N/A	N/A	N/A
2005	2014	TT-R230	1KH-23145-00-00	1KH-23144-00-00	N/A	N/A	N/A	N/A	N/A	N/A
2015	2017	TT-R230	1KH-23145-00-00	1KH-23144-00-00	N/A	N/A	N/A	N/A	N/A	N/A
1999	2006	TT-R250	3XJ-23145-L0-00	2VM-23144-L0-00	N/A	N/A	N/A	N/A	N/A	N/A
2006	2016	TT-R50	N/A	N/A	N/A	N/A	N/A	N/A	N/A	N/A
2000	2002	TT-R90	1RY-23145-00-00	3M7-23144-00-00	N/A	N/A	N/A	N/A	N/A	N/A
2003	2007	TT-R90	1RY-23145-00-00	3M7-23144-00-00	N/A	N/A	N/A	N/A	N/A	N/A

# OFF-ROAD MCY.

# OFF-ROAD MCY.

## YAMAHA GENUINE PARTS

Model Year	Model	Battery	Spark Plug	Air Cleaner	Front Brake Pad (Qty)	Rear Brake Pad (Qty)	Front Brake Shoe (Qty)	Rear Brake Shoe (Qty)	Drive Chain	Front Sprocket	Rear Sprocket
1995	WR250	N/A	B8E-G0000-00-00	4PE-14451-01-0	4SS-W0045-00-00 (1)	4GY-W0046-00-00 (1)	N/A	N/A	9Y581-08115-00	93834-14050-00	26A-25452-51-00
2001	WR250F	N/A	CR9-E0000-00-00	4XM-14451-00-00	5MV-W0045-01-00 (1)	5GR-W0046-00-00 (1)	N/A	N/A	9Y582-39113-00	9383B-13218-00	5GS-25448-50-00
2003	WR250F	YTX-5LBS0-00-00	CR9-E0000-00-00	5TJ-14451-00-00	5MV-W0045-01-00 (1)	5UN-W0046-60-00 (1)	N/A	N/A	9Y582-39113-00	9383B-13218-00	5GS-25448-50-00
2005	WR250F	YTX-5LBS0-00-00	CR9-E0000-00-00	5TJ-14451-00-00	5MV-W0045-01-00 (1)	5UN-W0046-60-00 (1)	N/A	N/A	9Y582-39113-00	9383B-13218-00	5TJ-25450-80-00
2006	WR250F	YTX-5LBS0-00-00	CR9-E0000-00-00	5TJ-14451-00-00	5MV-W0045-01-00 (1)	1C3-W0046-B0-00 (1)	N/A	N/A	9Y582-39113-00	9383B-13218-00	5TJ-25450-80-00
2007	WR250F	YTX-5LBS0-00-00	CR9-E0000-00-00	5UM-14451-E0-00	5MV-W0045-01-00 (1)	1C3-W0046-B0-00 (1)	N/A	N/A	9Y582-39113-00	9383B-13218-00	5TJ-25450-80-00
2008	WR250F	YZT-7SHE0-00-00	CR9-E0000-00-00	5UM-14451-E0-00	5MV-W0045-01-00 (1)	1C3-W0046-B0-00 (1)	N/A	N/A	9Y582-39113-00	9383B-13218-00	5TJ-25450-80-00
2013	WR250F	YZT-7SHE0-00-00	CR9-E0000-00-00	5UM-14451-E0-00	5MV-W0045-01-00 (1)	1C3-W0046-B0-00 (1)	N/A	N/A	9Y582-39113-00	3D7-17460-00-00	5TJ-25450-80-00
2015	WR250F	YZT-7SHE0-00-00	LMA-R8G00-00-00	1SL-14451-00-00	5MV-W0045-01-00 (1)	1C3-W0046-B0-00 (1)	N/A	N/A	9Y58F-39113-00	9383B-13218-00	5TJ-25450-80-00
2017	WR250F	YZT-7SHE0-00-00	LMA-R8G00-00-00	1SL-14451-00-00	B29-25805-00-00 (1)	1C3-W0046-B0-00 (1)	N/A	N/A	9Y58F-39113-00	9383B-13218-00	5TJ-25450-80-00
1998	WR400	N/A	CR8-E0000-00-00	4XM-14451-00-00	5DH-W0045-00-00 (1)	5GF-W0046-00-00 (1)	N/A	N/A	94581-76114-00	9383E-14215-00	5GS-25448-50-00
2001	WR426	N/A	CR8-E0000-00-00	4XM-14451-00-00	5MV-W0045-01-00 (1)	5GF-W0046-00-00 (1)	N/A	N/A	94581-76114-00	5NG-17460-00-00	5GS-25448-50-00
2003	WR426	N/A	CR8-E0000-00-00	4XM-14451-00-00	5MV-W0045-01-00 (1)	5GF-W0046-00-00 (1)	N/A	N/A	94581-76114-00	5NG-17460-00-00	5GS-25448-50-00
2003	WR450F	YZT-7SHE0-00-00	CR8-E0000-00-00	5TJ-14451-00-00	5MV-W0045-01-00 (1)	5UN-W0046-51-00 (1)	N/A	N/A	9Y582-39113-00	5NG-17460-00-00	5GS-25448-50-00
2005	WR450F	YZT-7SHE0-00-00	CR8-E0000-00-00	5TJ-14451-00-00	5MV-W0045-01-00 (1)	5UN-W0046-51-00 (1)	N/A	N/A	9Y582-39113-00	5NG-17460-00-00	5TJ-25450-80-00
2006	WR450F	YZT-7SHE0-00-00	CR8-E0000-00-00	5TJ-14451-00-00	5MV-W0045-01-00 (1)	1C3-W0046-B0-00 (1)	N/A	N/A	9Y582-39113-00	5NG-17460-00-00	5TJ-25450-80-00
2007	WR450F	YZT-7SHE0-00-00	CR8-E0000-00-00	5UM-14451-E0-00	5MV-W0045-01-00 (1)	1C3-W0046-B0-00 (1)	N/A	N/A	9Y582-39113-00	5TJ-17460-00-00	5TJ-25450-80-00
2012	WR450F	YZT-7SHE0-00-00	CR8-E0000-00-00	5UM-14451-E0-00	5MV-W0045-01-00 (1)	1C3-W0046-B0-00 (1)	N/A	N/A	9Y582-39113-00	5TJ-17460-00-00	5TJ-25450-80-00
2014	WR450F	YZT-7SHE0-00-00	CR8-E0000-00-00	5UM-14451-E0-00	5MV-W0045-01-00 (1)	1C3-W0046-B0-00 (1)	N/A	N/A	9Y582-39113-00	5TJ-17460-00-00	5TJ-25450-80-00
2015	WR450F	BTY-YTZ7S-HE-00	CR9-E0000-00-00	5UM-14451-E0-00	B29-25805-00-00	1C3-W0046-50-00 (1)	N/A	N/A	9Y58F-39113-00	9383E-13233-00	5TJ-25450-80-00
2017	WR450F	YZT-7SHE0-00-00	CR9-E0000-00-00	1SL-14451-00-00	B29-25805-00-00 (1)	1C3-W0046-B0-00 (1)	N/A	N/A	9Y58F-39113-00	9383E-13233-00	5TJ-25450-80-00
1995	YZ80	N/A	B10-EG000-00-00	4ES-14451-00-00	4ES-W0045-00-00 (1)	4ES-W0046-50-00 (1)	N/A	N/A	9Y581-58117-00	93822-14037-00	4ES-25447-00-XX
1997	YZ80	N/A	B10-EG000-00-00	4ES-14451-00-00	4ES-W0045-00-00 (1)	4ES-W0046-50-00 (1)	N/A	N/A	9Y581-58117-00	93822-14037-00	4ES-25448-00-00
1998	YZ80	N/A	B10-EG000-00-00	4ES-14451-00-00	4ES-W0045-00-00 (1)	4ES-W0046-50-00 (1)	N/A	N/A	9Y581-58117-00	93822-14037-00	4ES-25448-00-00
2000	YZ80	N/A	B10-EG000-00-00	4ES-14451-00-00	4ES-W0045-00-00 (1)	4ES-W0046-50-00 (1)	N/A	N/A	9Y581-58117-00	93822-15065-00	4ES-25448-00-00
2002	YZ85	N/A	B10-EG000-00-00	5PA-14451-00-00	5PA-W0045-00-00 (1)	5PA-W0046-50-00 (1)	N/A	N/A	9Y582-00117-00	9382A-15228-00	5PA-25448-00-00
2003	YZ85	N/A	B10-EG000-00-00	5PA-14451-00-00	5PA-W0045-00-00 (1)	5PA-W0046-50-00 (1)	N/A	N/A	9Y582-00117-00	9382A-15228-00	5PA-25448-00-00
2004	YZ85	N/A	B10-EG000-00-00	5PA-14451-00-00	5PA-W0045-00-00 (1)	5PA-W0046-50-00 (1)	N/A	N/A	9Y582-00117-00	9382A-15228-00	5PA-25448-00-00
2016	YZ85	N/A	B10-EG000-00-00	5PA-14451-00-00	5PA-W0045-00-00 (1)	5PA-W0046-50-00 (1)	N/A	N/A	9Y582-43117-00	9382A-15228-00	5PA-25448-00-00



# OFF-ROAD MCY.

# OFF-ROAD MCY.

## YAMAHA GENUINE PARTS

Model Year	Model	Front Fork Seal Kit	Fork Oil Seal	Fork Dust Seal	Bearing Kit - Shock Linkage	Bearing Kit - Swing Arm Pivot	Gasket Kit - Top End	Gasket Kit - Bottom End	Clutch Kit
1995	WR250	N/A	3XJ-23145-L0-00	4PU-23144-00-00	N/A	N/A	N/A	N/A	N/A
2001	WR250F	N/A	5UN-23145-L0-00	5HD-23144-L0-00	N/A	N/A	5NL-W0001-00-00	5NL-W0002-00-00	N/A
2003	WR250F	5ET-W003B-00-00	5UN-23145-L0-00	5HD-23144-L0-00	N/A	N/A	5NL-W0001-00-00	5NL-W0002-00-00	N/A
2005	WR250F	1C3-W003B-00-00	1C3-23145-L0-00	5XE-23144-L0-00	N/A	N/A	5NL-W0001-00-00	5NL-W0002-00-00	N/A
2006	WR250F	1C3-W003B-00-00	1C3-23145-L0-00	5XE-23144-L0-00	N/A	1HC-W002C-00-00	5NL-W0001-00-00	5NL-W0002-00-00	N/A
2007	WR250F	1C3-W003B-00-00	1C3-23145-L0-00	5XE-23144-L0-00	1HC-W002E-00-00	1HC-W002C-00-00	5NL-W0001-00-00	5NL-W0002-00-00	N/A
2008	WR250F	1C3-W003B-00-00	1C3-23145-L0-00	5XE-23144-L0-00	1HC-W002E-00-00	1HC-W002C-00-00	5NL-W0001-00-00	5NL-W0002-00-00	N/A
2013	WR250F	1C3-W003B-00-00	1C3-23145-L0-00	5XE-23144-L0-00	1HC-W002E-00-00	1HC-W002C-00-00	5NL-W0001-00-00	5NL-W0002-00-00	N/A
2015	WR250F	1C3-W003B-00-00	17D-23145-00-00 (2)	5XE-23144-L0-00	1HC-W002E-00-00	1HC-W002C-00-00	5NL-W0001-00-00	5NL-W0002-00-00	N/A
2017	WR250F	17D-W003B-00-00	17D-23145-00-00	5XE-23144-L0-00	33D-W002C-00-00	33D-W002C-00-00	5NL-W0001-00-00	5NL-W0002-00-00	N/A
1998	WR400	5ET-W003B-00-00	5UN-23145-L0-00	5HD-23144-L0-00	N/A	N/A	N/A	N/A	N/A
2001	WR426	5ET-W003B-00-00	5UN-23145-L0-00	5HD-23144-L0-00	N/A	N/A	N/A	N/A	N/A
2003	WR426	N/A	5UN-23145-L0-00	5HD-23144-L0-00	N/A	N/A	N/A	N/A	N/A
2003	WR450F	5ET-W003B-00-00	17D-23145-00-00	5HD-23144-L0-00	N/A	N/A	5TA-W0001-00-00	N/A	N/A
2005	WR450F	1C3-W003B-00-00	17D-23145-00-00	5HD-23144-L0-00	N/A	N/A	5TA-W0001-00-00	N/A	5TJ-W001G-00-00
2006	WR450F	1C3-W003B-00-00	17D-23145-00-00	5HD-23144-L0-00	N/A	1HC-W002C-00-00	5TA-W0001-00-00	N/A	5TJ-W001G-00-00
2007	WR450F	1C3-W003B-00-00	17D-23145-00-00	5HD-23144-L0-00	1HC-W002E-00-00	1HC-W002C-00-00	2S2-W0001-00-00	2S2-W0002-00-00	5TJ-W001G-00-00
2012	WR450F	17D-W003B-00-00	17D-23145-00-00	5XE-23144-L0-00	1HC-W002E-00-00	1HC-W002C-00-00	2S2-W0001-00-00	2S2-W0002-00-00	5TJ-W001G-00-00
2014	WR450F	17D-W003B-00-00	17D-23145-00-00	5XE-23144-L0-00	1HC-W002E-00-01	1HC-W002C-00-00	2S2-W0001-00-00	2S2-W0002-00-00	5TJ-W001G-00-00
2015	WR450F	17D-W003B-00-00	17D-23145-00-00	5XE-23144-L0-00	33D-W002E-00-00	33D-W002C-00-00	1SL-W0001-00-00	2S2-W0002-00-00	1SL-W001G-00-00
2017	WR450F	17D-W003B-00-00	17D-23145-00-00	5XE-23144-L0-00	33D-W002E-00-00	33D-W002C-00-00	1SL-W0001-00-00	2S2-W0002-00-00	TBD
1995	YZ80	N/A	4ES-23145-00-00	4ES-23144-00-00	N/A	N/A	N/A	N/A	N/A
1997	YZ80	4ES-W003B-00-00	4ES-23145-00-00	4ES-23144-00-00	N/A	N/A	N/A	N/A	N/A
1998	YZ80	4ES-W003B-00-00	4ES-23145-00-00	4ES-23144-00-00	N/A	1SN-W002C-00-00	N/A	N/A	N/A
2000	YZ80	4ES-W003B-00-00	4ES-23145-00-00	4ES-23144-00-00	N/A	1SN-W002C-00-00	N/A	N/A	N/A
2002	YZ85	4ES-W003B-00-00	4ES-23145-00-00	4ES-23144-00-00	N/A	1SN-W002C-00-00	5PA-W0001-00-00	N/A	N/A
2003	YZ85	4ES-W003B-00-00	4ES-23145-00-00	4ES-23144-00-00	1SN-W002E-00-00	1SN-W002C-00-00	5PA-W0001-00-00	N/A	N/A
2004	YZ85	4ES-W003B-00-00	4ES-23145-00-00	4ES-23144-00-00	1SN-W002E-00-00	1SN-W002C-00-00	5PA-W0001-00-00	N/A	5PA-W001G-00-00
2016	YZ85	4ES-W003B-00-00	4ES-23145-00-00	4ES-23144-00-00	1SN-W002E-00-00	1SN-W002C-00-00	5PA-W0001-00-00	N/A	5PA-W001G-00-00

# OFF-ROAD MCY.

# OFF-ROAD MCY.

## YAMAHA GENUINE PARTS

Model Year	Model	Battery	Spark Plug	Air Cleaner	Front Brake Pad (Qty)	Rear Brake Pad (Qty)	Front Brake Shoe (Qty)	Rear Brake Shoe (Qty)	Drive Chain	Front Sprocket	Rear Sprocket
1995	YZ125	N/A	B9E-G0000-00-00	4PE-14451-01-00	4SS-W0045-00-00 (1)	4GY-W0046-00-00 (1)	N/A	N/A	9Y581-92113-00	9383A-14054-00	3R4-25450-01-XX
1996	YZ125	N/A	B9E-G0000-00-00	4XM-14451-00-00	4SS-W0045-00-00 (1)	4GY-W0046-00-00 (1)	N/A	N/A	9Y581-92113-00	9383A-14054-00	4SS-25450-00-00
1998	YZ125	N/A	BR9-EG000-00-00	4XM-14451-00-00	5DH-W0045-00-00 (1)	5DH-W0046-00-00 (1)	N/A	N/A	9Y581-92113-00	9383A-14054-00	4SS-25450-00-00
1999	YZ125	N/A	BR9-EG000-00-00	4XM-14451-00-00	5DH-W0045-00-00 (1)	5GR-W0046-00-00 (1)	N/A	N/A	9Y581-92113-00	9383A-14054-00	4SS-25450-00-00
2000	YZ125	N/A	BR9-EG000-00-00	4XM-14451-00-00	5MV-W0045-01-00 (1)	5GR-W0046-00-00 (1)	N/A	N/A	9Y582-28111-00	9383A-14054-00	1C3-25448-00-00
2003	YZ125	N/A	BR9-EG000-00-00	4XM-14451-00-00	5MV-W0045-01-00 (1)	5UN-W0046-50-00 (1)	N/A	N/A	9Y582-28111-00	9383A-14054-00	1C3-25448-00-00
2004	YZ125	N/A	BR9-EG000-00-00	4XM-14451-00-00	5MV-W0045-01-00 (1)	5UN-W0046-50-00 (1)	N/A	N/A	9Y582-28111-00	9383A-14054-00	1C3-25448-00-00
2005	YZ125	N/A	BR9-EG000-00-00	4XM-14451-00-00	5MV-W0045-01-00 (1)	5UN-W0046-50-00 (1)	N/A	N/A	9Y582-28111-00	9383B-13218-00	1C3-25448-00-00
2006	YZ125	N/A	BR9-EIX00-00-00	4XM-14451-00-00	5MV-W0045-01-00 (1)	1C3-W0046-50-00 (1)	N/A	N/A	9Y582-28111-00	9383B-13218-00	1C3-25448-00-00
2008	YZ125	N/A	BR9-EIX00-00-00	4XM-14451-00-00	5XC-W0045-00-00 (1)	1C3-W0046-50-00 (1)	N/A	N/A	9Y582-28111-00	9383B-13218-00	1C3-25448-00-00
2009	YZ125	N/A	BR9-EIX00-00-00	4XM-14451-00-00	5XC-W0045-00-00 (1)	1C3-W0046-50-00 (1)	N/A	N/A	9Y582-28111-00	9383B-13218-00	1C3-25448-00-00
2015	YZ125	N/A	BR9-EIX00-00-00	4XM-14451-00-00	5XC-W0045-00-00 (1)	1C3-W0046-50-00 (1)	N/A	N/A	9Y582-28111-00	9383B-13218-00	17D-25448-50-00
2017	YZ125	N/A	BR9-EIX00-00-00	4XM-14451-00-00	B29-25805-00-00 (1)	1C3-W0046-50-00 (1)	N/A	N/A	9Y582-28111-00	9383B-13218-00	17D-25448-50-00
1995	YZ250	N/A	B8E-G0000-00-00	4PE-14451-01-00	4SS-W0045-00-00 (1)	4GY-W0046-00-00 (1)	N/A	N/A	9Y581-92113-00	93834-13206-00	3R4-25449-01-XX
1996	YZ250	N/A	BR8-EG000-00-00	4SS-14451-00-00	4SS-W0045-00-00 (1)	4GY-W0046-00-00 (1)	N/A	N/A	9Y581-92113-00	93834-13206-00	3R4-25449-01-XX
1997	YZ250	N/A	BR8-EG000-00-00	4XM-14451-00-00	4SS-W0045-00-00 (1)	4GY-W0046-00-00 (1)	N/A	N/A	9Y581-92113-00	93834-13206-00	3R4-25449-01-XX
1998	YZ250	N/A	BR8-EG000-00-00	4XM-14451-00-00	4SS-W0045-00-00 (1)	4GY-W0046-00-00 (1)	N/A	N/A	9Y581-92113-00	93834-13206-00	3R4-25449-01-XX
1999	YZ250	N/A	BR8-EG000-00-00	4XM-14451-00-00	5DH-W0045-00-00 (1)	5DH-W0046-00-00 (1)	N/A	N/A	9Y581-92113-00	93834-14050-00	4SS-25450-00-00
1999	YZ250	N/A	BR8-EG000-00-00	4XM-14451-00-00	5DH-W0045-00-00 (1)	5DH-W0046-00-00 (1)	N/A	N/A	9Y581-92113-00	93834-14050-00	4SS-25450-00-00
2000	YZ250	N/A	BR8-EG000-00-00	4XM-14451-00-00	5MV-W0045-01-00 (1)	5GR-W0046-00-00 (1)	N/A	N/A	9Y582-28113-00	9383E-14215-00	5ET-25450-00-00
2002	YZ250	N/A	BR8-EG000-00-00	4XM-14451-00-00	5MV-W0045-01-00 (1)	5GR-W0046-00-00 (1)	N/A	N/A	9Y582-28113-00	9383E-14215-00	1C3-25448-00-00
2003	YZ250	N/A	BR8-EG000-00-00	4XM-14451-00-00	5MV-W0045-01-00 (1)	5UN-W0046-00-00 (1)	N/A	N/A	9Y582-28113-00	9383E-14215-00	1C3-25448-00-00
2004	YZ250	N/A	BR8-EG000-00-00	4XM-14451-00-00	5MV-W0045-01-00 (1)	5UN-W0046-00-00 (1)	N/A	N/A	9Y582-28113-00	9383E-14215-00	1C3-25448-00-00
2005	YZ250	N/A	BR8-EG000-00-00	4XM-14451-00-00	5MV-W0045-01-00 (1)	5UN-W0046-00-00 (1)	N/A	N/A	9Y582-28113-00	9383E-14215-00	1C3-25448-00-00
2006	YZ250	N/A	BR8-EG000-00-00	4XM-14451-00-00	5MV-W0045-01-00 (1)	5UN-W0046-00-00 (1)	N/A	N/A	9Y582-28113-00	9383E-14215-00	1C3-25448-00-00
2008	YZ250	N/A	BR8-EG000-00-00	4XM-14451-00-00	5XC-W0045-00-00 (1)	5UN-W0046-00-00 (1)	N/A	N/A	9Y582-28113-00	9383E-14215-00	1C3-25448-00-00
2009	YZ250	N/A	BR8-EG000-00-00	4XM-14451-00-00	5XC-W0045-00-00 (1)	5UN-W0046-00-00 (1)	N/A	N/A	9Y582-28113-00	9383E-14215-00	1C3-25448-00-00
2015	YZ250	N/A	BR8-EG000-00-00	4XM-14451-00-00	5XC-W0045-00-00 (1)	1C3-W0046-10-00 (1)	N/A	N/A	9Y581-92113-00	9383E-14215-00	17D-25450-50-00
2017	YZ250	N/A	BR9-EG000-00-00	4XM-14451-00-00	B29-25805-00-00 (1)	1C3-W0046-10-00 (1)	N/A	N/A	9Y582-28113-00	9383E-14215-00	17D-25450-50-00

## YAMAHA GENUINE PARTS

Model Year	Model	Front Fork Seal Kit	Fork Oil Seal	Fork Dust Seal	Bearing Kit - Shock Linkage	Bearing Kit - Swing Arm Pivot	Gasket Kit - Top End	Gasket Kit - Bottom End	Clutch Kit
1995	YZ125	N/A	3XJ-23145-LO-00	4PU-23144-00-00	N/A	N/A	N/A	N/A	N/A
1996	YZ125	N/A	5UN-23145-LO-00	5HD-23144-LO-00	N/A	N/A	N/A	N/A	N/A
1998	YZ125	N/A	5UN-23145-LO-00	5HD-23144-LO-00	N/A	N/A	N/A	N/A	N/A
1999	YZ125	5ET-W003B-00-00	5UN-23145-LO-00	5HD-23144-LO-00	N/A	N/A	N/A	N/A	N/A
2000	YZ125	5ET-W003B-00-00	5UN-23145-LO-00	5HD-23144-LO-00	N/A	N/A	N/A	N/A	N/A
2003	YZ125	5ET-W003B-00-00	5UN-23145-LO-00	5HD-23144-LO-00	N/A	N/A	N/A	N/A	N/A
2004	YZ125	1C3-W003B-00-00	5XE-23145-LO-00	5XE-23144-LO-00	N/A	N/A	N/A	N/A	N/A
2005	YZ125	1C3-W003B-00-00	1C3-23145-LO-00	5XE-23144-LO-00	N/A	N/A	1C3-W0001-00-00	N/A	N/A
2006	YZ125	1C3-W003B-00-00	1C3-23145-LO-00	5XE-23144-LO-00	N/A	1C3-W002C-00-00	1C3-W0001-00-00	N/A	1C3-W001G-00-00
2008	YZ125	1C3-W003B-00-00	1C3-23145-LO-00	5XE-23144-LO-00	1P8-W002E-00-00	1C3-W002C-00-00	1C3-W0001-00-00	N/A	1C3-W001G-00-00
2009	YZ125	1C3-W003B-00-00	1C3-23145-LO-00	5XE-23144-LO-00	1SR-W002E-00-00	1C3-W002C-00-00	1C3-W0001-00-00	N/A	1C3-W001G-00-00
2015	YZ125	TBD	17D-23145-00-00	5XE-23144-LO-00	1SR-W002E-00-00	1C3-W002C-00-00	1C3-W0001-00-00	N/A	1C3-W001G-00-00
2017	YZ125	17D-W003B-00-00	17D-23145-00-00	5XE-23144-LO-00	TBD	TBD	TBD	TBD	TBD
1995	YZ250	N/A	3XJ-23145-LO-00	4PU-23144-00-00	N/A	N/A	N/A	N/A	N/A
1996	YZ250	N/A	5UN-23145-LO-00	5HD-23144-LO-00	N/A	N/A	N/A	N/A	N/A
1997	YZ250	N/A	5UN-23145-LO-00	5HD-23144-LO-00	N/A	N/A	N/A	N/A	N/A
1998	YZ250	N/A	5UN-23145-LO-00	5HD-23144-LO-00	N/A	N/A	N/A	N/A	N/A
1999	YZ250	5ET-W003B-00-00	5UN-23145-LO-00	5HD-23144-LO-00	N/A	N/A	N/A	N/A	N/A
2000	YZ250	5ET-W003B-00-00	5UN-23145-LO-00	5HD-23144-LO-00	N/A	N/A	N/A	N/A	N/A
2002	YZ250	5ET-W003B-00-00	5UN-23145-LO-00	5HD-23144-LO-00	N/A	N/A	N/A	N/A	N/A
2003	YZ250	5ET-W003B-00-00	5UN-23145-LO-00	5HD-23144-LO-00	N/A	N/A	1P8-W0001-00-00	N/A	1P8-W001G-00-00
2004	YZ250	1C3-W003B-00-00	5XE-23145-LO-00	5XE-23144-LO-00	N/A	N/A	1P8-W0001-00-00	N/A	1P8-W001G-00-00
2005	YZ250	1C3-W003B-00-00	1C3-23145-LO-00	5XE-23144-LO-00	1P8-W002E-00-00	N/A	1P8-W0001-00-00	N/A	1P8-W001G-00-00
2006	YZ250	1C3-W003B-00-00	1C3-23145-LO-00	5XE-23144-LO-00	1P8-W002E-00-00	1HC-W002C-00-00	1P8-W0001-00-00	N/A	1P8-W001G-00-00
2008	YZ250	1C3-W003B-00-00	1C3-23145-LO-00	5XE-23144-LO-00	1P8-W002E-00-00	1HC-W002C-00-00	1P8-W0001-00-00	N/A	1P8-W001G-00-00
2009	YZ250	1C3-W003B-00-00	1C3-23145-LO-00	5XE-23144-LO-00	1SR-W002E-00-00	1HC-W002C-00-00	1P8-W0001-00-00	N/A	1P8-W001G-00-00
2015	YZ250	TBD	17D-23145-00-00	5XE-23144-LO-00	1SR-W002E-00-00	1HC-W002C-00-00	1P8-W0001-00-00	TBD	1P8-W001G-00-00
2017	YZ250	17D-W003B-00-00	17D-23145-00-00	5XE-23144-LO-00	1SR-W002E-00-00	1HC-W002C-00-00	1P8-W0001-00-00	TBD	1P8-W001G-00-00

# OFF-ROAD MCV.

# OFF-ROAD MCV.

## YAMAHA GENUINE PARTS

Model Year	Model	Battery	Spark Plug	Air Cleaner	Front Brake Pad (Qty)	Rear Brake Pad (Qty)	Front Brake Shoe (Qty)	Rear Brake Shoe (Qty)	Drive Chain	Front Sprocket	Rear Sprocket
2001	YZ250F	N/A	CR9-E0000-00-00	4XM-14451-00-00	5MV-W0045-01-00 (1)	5GF-W0046-00-00 (1)	N/A	N/A	9Y582-28113-00	9383B-13218-00	1C3-25448-00-00
2003	YZ250F	N/A	CR9-E0000-00-00	4XM-14451-00-00	5MV-W0045-01-00 (1)	5UN-W0046-00-00 (1)	N/A	N/A	9Y582-28113-00	9383B-13218-00	1C3-25448-00-00
2004	YZ250F	N/A	CR9-E0000-00-00	4XM-14451-00-00	5MV-W0045-01-00 (1)	5UN-W0046-00-00 (1)	N/A	N/A	9Y582-28113-00	9383B-13218-00	1C3-25448-00-00
2005	YZ250F	N/A	CR9-E0000-00-00	4XM-14451-00-00	5MV-W0045-01-00 (1)	5UN-W0046-00-00 (1)	N/A	N/A	9Y582-28113-00	9383B-13218-00	1C3-25448-00-00
2006	YZ250F	N/A	CR9-E0000-00-00	4XM-14451-00-00	5MV-W0045-01-00 (1)	1C3-W0046-50-00 (1)	N/A	N/A	9Y582-28113-00	9383B-13218-00	1C3-25448-00-00
2007	YZ250F	N/A	CR9-E0000-00-00	4XM-14451-00-00	5MV-W0045-01-00 (1)	1C3-W0046-50-00 (1)	N/A	N/A	9Y582-28113-00	9383B-13218-00	1C3-25448-00-00
2008	YZ250F	N/A	CR9-E0000-00-00	4XM-14451-00-00	5XC-W0045-00-00 (1)	1C3-W0046-50-00 (1)	N/A	N/A	9Y582-28113-00	9383B-13218-00	1C3-25448-00-00
2009	YZ250F	N/A	CR9-E0000-00-00	4XM-14451-00-00	5XC-W0045-00-00 (1)	1C3-W0046-50-00 (1)	N/A	N/A	9Y582-28113-00	9383B-13218-00	1C3-25448-00-00
2010	YZ250F	N/A	CR9-E0000-00-00	4XM-14451-00-00	5XC-W0045-00-00 (1)	1C3-W0046-50-00 (1)	N/A	N/A	9Y582-28113-00	9383B-13218-00	1C3-25448-00-00
2014	YZ250F	N/A	LMA-R8G00-00-00	1SL-14451-00-00	5XC-W0045-00-00 (1)	1C3-W0046-50-00 (1)	N/A	N/A	9Y582-28113-00	9383B-13218-00	17D-25449-50-00
2016	YZ250F	N/A	LMA-R8G00-00-00	1SL-14451-00-00	B29-25805-00-00 (1)	1C3-W0046-50-00 (1)	N/A	N/A	9Y582-28113-00	9383B-13218-00	17D-25449-50-00
2017	YZ250F	N/A	LMA-R8G00-00-00	1SL-14451-00-00	B29-25805-00-00 (1)	1C3-W0046-50-00 (1)	N/A	N/A	9Y582-28113-00	9383B-13218-00	17D-25449-50-00
2015	YZ250FX	YTZ-7SHE0-00-00	LMA-R8G00-00-00	1SL-14451-00-00	B29-25805-00-00 (1)	1C3-W0046-50-00 (1)	N/A	N/A	9Y58F-39113-00	9383B-13218-00	17D-25451-50-00
2017	YZ250FX	YTZ-7SHE0-00-00	LMA-R8G00-00-00	1SL-14451-00-00	B29-25805-00-00 (1)	1C3-W0046-50-00 (1)	N/A	N/A	9Y58F-39113-00	9383B-13218-00	17D-25452-50-00
2016	YZ250X	N/A	BR8-EG000-00-00	4XM-14451-00-00	5XC-W0045-00-00 (1)	1C3-W0046-10-00 (1)	N/A	N/A	9Y58F-39113-00	9383E-14215-00	17D-25450-50-00
2017	YZ250X	N/A	BR8-EG000-00-00	4XM-14451-00-00	B29-25805-00-00 (1)	1C3-W0046-10-00 (1)	N/A	N/A	9Y58F-39113-00	9383E-14215-00	17D-25452-50-00
1999	YZ400F	N/A	CR8-E0000-00-00	4XM-14451-00-00	5DH-W0045-00-00 (1)	5GR-W0046-00-00 (1)	N/A	N/A	9Y581-92113-00	9383E-14215-00	1C3-25448-00-00
2000	YZ426F	N/A	CR9-E0000-00-00	4XM-14451-00-00	5MV-W0045-01-00 (1)	5GF-W0046-00-00 (1)	N/A	N/A	94581-76114-00	9383E-14215-00	1C3-25448-00-00
2003	YZ450F	N/A	CR9-E0000-00-00	4XM-14451-00-00	5MV-W0045-01-00 (1)	5UN-W0046-51-00 (1)	N/A	N/A	9Y582-28113-00	9383E-14215-00	1C3-25448-00-00
2004	YZ450F	N/A	CR9-E0000-00-00	4XM-14451-00-00	5MV-W0045-01-00 (1)	5UN-W0046-51-00 (1)	N/A	N/A	9Y582-28113-00	9383E-14215-00	1C3-25448-00-00
2006	YZ450F	N/A	CR9-E0000-00-00	4XM-14451-00-00	5MV-W0045-01-00 (1)	1C3-W0046-50-00 (1)	N/A	N/A	9Y582-28113-00	9383E-13233-00	1C3-25448-00-00
2008	YZ450F	N/A	CR9-E0000-00-00	4XM-14451-00-00	5XC-W0045-00-00 (1)	1C3-W0046-50-00 (1)	N/A	N/A	9Y582-28113-00	9383E-13233-00	1C3-25448-00-00
2009	YZ450F	N/A	CR9-E0000-00-00	4XM-14451-00-00	5XC-W0045-00-00 (1)	1C3-W0046-50-00 (1)	N/A	N/A	9Y582-28113-00	9383E-13233-00	1C3-25448-00-00
2010	YZ450F	N/A	CR9-E0000-00-00	33D-14451-00-00	5XC-W0045-00-00 (1)	1C3-W0046-50-00 (1)	N/A	N/A	9Y582-28113-00	9383E-13233-00	17D-25449-50-00
2014	YZ450F	N/A	CR9-E0000-00-00	1SL-14451-00-00	5XC-W0045-00-00 (1)	1C3-W0046-50-00 (1)	N/A	N/A	9Y582-28113-00	9383E-13233-00	17D-25449-50-00
2015	YZ450F	N/A	CR9-E0000-00-00	1SL-14451-00-00	5XC-W0045-00-00 (1)	1C3-W0046-50-00 (1)	N/A	N/A	9Y582-28113-00	9383E-13233-00	17D-25449-50-00
2016	YZ450F	N/A	CR9-E0000-00-00	1SL-14451-00-01	5XC-W0045-00-00 (1)	1C3-W0046-50-00 (1)	N/A	N/A	9Y582-28113-00	9383E-13233-00	17D-25449-50-00
2017	YZ450F	N/A	CR9-E0000-00-00	1SL-14451-00-00	B29-25805-00-00 (1)	1C3-W0046-50-00 (1)	N/A	N/A	9Y582-28113-00	9383E-13233-00	17D-25452-50-00
2016	YZ450FX	BTY-YTZ7S-HE-00	CR9-E0000-00-00	1SL-14451-00-01	B29-25805-00-00 (1)	1C3-W0046-50-00 (1)	N/A	N/A	9Y582-28113-00	9383E-13233-00	17D-25452-50-00
2017	YZ450FX	YTZ-7SHE0-00-00	CR9-E0000-00-00	1SL-14451-00-00	B29-25805-00-00 (1)	1C3-W0046-50-00 (1)	N/A	N/A	9Y58F-39113-00	9383E-13233-00	17D-25452-50-00

# OFF-ROAD MCY.

# OFF-ROAD MCY.

## YAMAHA GENUINE PARTS

Model Year	Model	Front Fork Seal Kit	Fork Oil Seal	Fork Dust Seal	Bearing Kit - Shock Linkage	Bearing Kit - Swing Arm Pivot	Gasket Kit - Top End	Gasket Kit - Bottom End	Clutch Kit
2001	YZ250F	5ET-W003B-00-00	5UN-23145-L0-00	5HD-23144-L0-00	N/A	N/A	5NL-W0001-00-00	5NL-W0002-00-00	N/A
2003	YZ250F	5ET-W003B-00-00	5UN-23145-L0-00	5HD-23144-L0-00	N/A	N/A	5NL-W0001-00-00	5NL-W0002-00-00	N/A
2004	YZ250F	1C3-W003B-00-00	5XE-23145-L0-00	5XE-23144-L0-00	N/A	N/A	5NL-W0001-00-00	5NL-W0002-00-00	N/A
2005	YZ250F	1C3-W003B-00-00	1C3-23145-L0-00	5XE-23144-L0-00	N/A	N/A	5NL-W0001-00-00	5NL-W0002-00-00	N/A
2006	YZ250F	1C3-W003B-00-00	1C3-23145-L0-00	5XE-23144-L0-00	N/A	1HC-W002C-00-00	5NL-W0001-00-00	5NL-W0002-00-00	N/A
2007	YZ250F	1C3-W003B-00-00	1C3-23145-L0-00	5XE-23144-L0-00	1P8-W002E-00-00	1HC-W002C-00-00	5NL-W0001-00-00	5NL-W0002-00-00	N/A
2008	YZ250F	1C3-W003B-00-00	1C3-23145-L0-00	5XE-23144-L0-00	1HC-W002E-00-00	1HC-W002C-00-00	5NL-W0001-00-00	5NL-W0002-00-00	N/A
2009	YZ250F	1C3-W003B-00-00	1C3-23145-L0-00	5XE-23144-L0-00	33D-W002E-00-00	1HC-W002C-00-00	5NL-W0001-00-00	5NL-W0002-00-00	N/A
2010	YZ250F	17D-W003B-00-00	17D-23145-00-00	5XE-23144-L0-00	17D-W002E-00-00	1HC-W002C-00-00	5NL-W0001-00-00	5NL-W0002-00-00	N/A
2014	YZ250F	17D-W003B-00-00	17D-23145-00-00	5XE-23144-L0-00	33D-W002E-00-00	33D-W002C-00-00	1SM-W0001-00-00	1SM-W0002-00-00	1SM-W001G-00-00
2016	YZ250F	17D-W003B-00-00	17D-23145-00-00	5XE-23144-L0-00	33D-W002E-00-00	33D-W002C-00-00	1SM-W0001-00-00	1SM-W0002-00-00	1SM-W001G-00-00
2017	YZ250F	17D-W003B-00-00	17D-23145-00-00	5XE-23144-L0-00	33D-W002E-00-00	33D-W002C-00-00	1SM-W0001-00-00	1SM-W0002-00-00	1SM-W001G-00-00
2015	YZ250FX	17D-W003B-00-00	17D-23145-00-00	5XE-23144-L0-00	33D-W002E-00-00	33D-W002C-00-00	N/A	N/A	1SM-W001G-00-00
2017	YZ250FX	17D-W003B-00-00	17D-23145-00-00	5XE-23144-L0-00	33D-W002C-00-00	33D-W002C-00-00	N/A	N/A	1SM-W001G-00-00
2016	YZ250X	1C3-W003B-00-00	17D-23145-00-00	5XE-23144-L0-00	N/A	N/A	N/A	N/A	N/A
2017	YZ250X	17D-W003B-00-00	17D-23145-00-00	5XE-23144-L0-00	N/A	N/A	N/A	N/A	N/A
1999	YZ400F	5ET-W003B-00-00	5UN-23145-L0-00	5HD-23144-L0-00	N/A	N/A	N/A	N/A	N/A
2000	YZ426F	5ET-W003B-00-00	5UN-23145-L0-00	5HD-23144-L0-00	N/A	N/A	N/A	N/A	N/A
2003	YZ450F	5ET-W003B-00-00	1C3-23145-L0-00	5HD-23144-L0-00	N/A	N/A	5TA-W0001-00-00	N/A	N/A
2004	YZ450F	1C3-W003B-00-00	1C3-23145-L0-00	5XE-23144-L0-00	N/A	N/A	5TA-W0001-00-00	N/A	N/A
2006	YZ450F	1C3-W003B-00-00	1C3-23145-L0-00	5XE-23144-L0-00	1HC-W002E-00-00	1HC-W002C-00-00	2S2-W0001-00-00	2S2-W0002-00-00	2S2-W001G-00-00
2008	YZ450F	1C3-W003B-00-00	1C3-23145-L0-00	5XE-23144-L0-00	1HC-W002E-00-00	1HC-W002C-00-00	2S2-W0001-00-00	2S2-W0002-00-00	2S2-W001G-00-00
2009	YZ450F	1C3-W003B-00-00	1C3-23145-L0-00	5XE-23144-L0-00	33D-W002E-00-00	1HC-W002C-00-00	2S2-W0001-00-00	2S2-W0002-00-00	2S2-W001G-00-00
2010	YZ450F	17D-W003B-00-00	17D-23145-00-00	N/A	N/A	N/A	33D-W0001-00-00	N/A	33D-W001G-00-00
2014	YZ450F	17D-W003B-00-00	17D-23145-00-00	5XE-23144-L0-00	33D-W002E-00-00	N/A	1SL-W0001-00-00	N/A	1SL-W001G-00-00
2015	YZ450F	17D-W003B-00-00	17D-23145-00-00	5XE-23144-L0-00	33D-W002E-00-00	33D-W002C-00-00	1SL-W0001-00-00	N/A	1SL-W001G-00-00
2016	YZ450F	17D-W003B-00-00	17D-23145-00-00	5XE-23144-L0-00	33D-W002E-00-00	33D-W002C-00-00	1SL-W0001-00-00	2S2-W0002-00-00	1SL-W001G-00-00
2017	YZ450F	17D-W003B-00-00	17D-23145-00-00	5XE-23144-L0-00	33D-W002E-00-00	33D-W002C-00-00	B11-W0001-00-00	B11-W0002-00-00	1SL-W001G-00-00
2016	YZ450FX	17D-W003B-00-00	17D-23145-00-00	5XE-23144-L0-00	33D-W002C-00-00	33D-W002C-00-00	1SL-W0001-00-00	2S2-W0002-00-00	1SL-W001G-00-00
2017	YZ450FX	17D-W003B-00-00	17D-23145-00-00	5XE-23144-L0-00	33D-W002E-00-00	33D-W002C-00-00	1SL-W0001-00-00	26C-W0002-00-00	1SL-W001G-00-00



## **California Regulations Regarding Emission-Related Parts and Accessories**

California law regulates on- and off-highway vehicle aftermarket parts that have the potential to impact emissions. California law prohibits the installation, sale, and on- and off-highway use of any emissions-related part unless the part is (1) a replacement part, (2) a modified or add-on part that has received an exemption from the California Air Resources Board ("ARB") or (3) a part installed on a vehicle used exclusively for closed-course competition (i.e., racing).

### **Replacement Part**

A replacement part is generally any aftermarket part intended to replace an original equipment emission-related part and which is functionally identical to the original equipment part in all respects that in any way affect emissions.

### **Modified Part or Add-On Part**

A modified part is any aftermarket part intended to replace an original equipment emissions-related part and which is not functionally identical to the original equipment part in all respects that in any way affect emissions. An add-on part is any aftermarket part which is not a modified part or a replacement part.

### **Closed-Course-Competition Part**

A closed-course-competition part is a modified part or add-on part that has not received an exemption from the ARB. A closed-course-competition part may only be sold and installed on a vehicle that is used exclusively for closed-course competition. California dealers selling closed-course-competition parts should maintain records of the sale and/or installation, including the date of sale, purchaser name and address, vehicle information and work performed, if applicable.

More information may be obtained at the ARB website - [www.arb.ca.gov](http://www.arb.ca.gov).

Manufacturer's suggested retail prices are shown. Prices may vary due to supply, freight, etc. Actual prices set by the dealer. Product and specifications subject to change without notice. Availability subject to production, stocking, and demand.

Dress properly for your ride with a helmet, eye protection and protective clothing. Avoid excessive speeds and never engage in stunt riding. Do not drink and ride; it is illegal and dangerous. Yamaha and the Motorcycle Safety Foundation encourage you to ride safely and respect the environment. For safety and training information, see your dealer or call the MSF at 800.446.9227.

This document contains many of the valuable trademarks and service marks owned and used by Yamaha throughout the world. The document may also contain references to other company, brand, and product names that may be the trademarks/ service marks of their respective owners. Unless noted otherwise, these company, brand, and product names are used herein for identification purposes only, and reference to any names, marks, products, or services of third parties do not constitute or imply endorsement, sponsorship, or recommendation of the third party or the products or services. iPhone, iPad, and Lightning are registered trademarks of Apple Inc.

©2017 Yamaha Motor Corporation, U.S.A. All rights reserved.  
Printed in U.S.A.

[ShopYamaha.com](http://ShopYamaha.com)



Yamaha Motor Corporation, U.S.A.  
6555 Katella Avenue  
Cypress, CA 90630

For a dealer near you, call 1-800-88-YAMAHA. Check us out on the web at [yamaha-motor.com](http://yamaha-motor.com)



LIT-YPDMX-02-17

**YAMALUBE**<sup>®</sup>

**GYTR**<sup>®</sup>  
GENUINE YAMAHA TECHNOLOGY RACING  
PERFORMANCE PRODUCTS

